



RTI ID **evo**



**Water-Cooled Chillers
with Leading Control
Technology**

High Efficiency Chillers
for High Performance
Buildings



Model RTHD (R134a)
550 - 1460 kW

TRANE
TECHNOLOGIES

Raising Your HVAC Experience to Unmatched Levels of Performance, Comfort and Economy

High performance buildings need high performance HVAC systems. Your buildings need to be one of the best so it is very important that they are supremely energy efficient, today, tomorrow and long into the future. A Trane RTHD^{evo} chiller provides reliable and dependable performance to ensure continuous delivery of precise temperature control across the full spectrum of demanding comfort and industrial applications.

Industry leading efficiency

To reach the highest standards of efficiency, Trane has 100 years of engineering expertise, world leading research and the most rigorous testing. As a result, Trane chillers, including the RTHD^{evo}, deliver superior full- and part-load performance, the key to exceptional energy efficiency. Performance achieves market-leading EER (Energy Efficiency Ratio) and ESEER (European Seasonal Energy Efficiency Ratio).

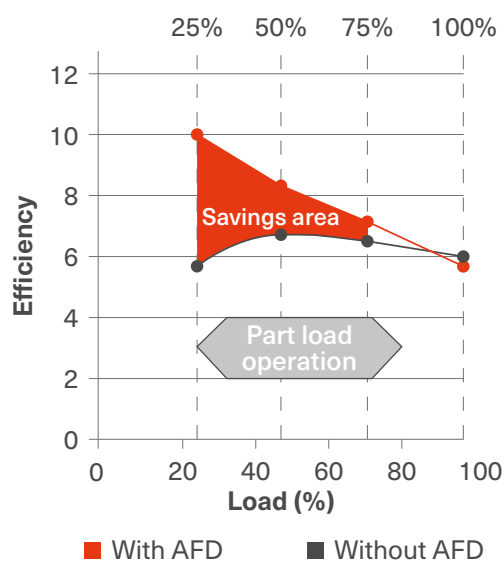

A model for every application

Whether your building, for example a hospital or a hotel, requires comfort cooling or precision temperature control as part of a sensitive industrial process, Trane offers suitable RTHD^{evo} models.

Minimized total cost of ownership

Energy costs are minimized by optimizing efficiency. Maintenance costs are reduced as a result of effective performance and alarm monitoring linked to equipment with proven dependability. Installation costs are lower thanks to design improvements which reduce the time required for new plants or upgrades. An Adaptive Frequency Drive, available with the top of the range RTHD^{evo} High Seasonal Efficiency model, reduces energy consumption even further by improving your chiller's efficiency under reduced load conditions.

Legendary Trane reliability

Your facility depends on an efficient, reliable HVAC system for employee comfort and well-being as well as for critical process applications. Trane reliability is legendary, based on over 75 years of designing, testing, installing and maintaining chillers around the world. Every Trane product guarantees that unique heritage and the pride we have in being the best at what we do.

Leading Control Technology

Trane Tracer™ UC800 + TD7 interface



Driving Reduced Energy Consumption

Developing our own control algorithm and software is one of our unique strengths. Trane does not just use a controller from a vendor and adapt it to its units. We take the matter a step further and develop the unit from the beginning.

Control

- The Tracer™ UC800 provides the intelligence behind the RTHD^{evo} chiller and features Adaptive Control algorithms: proprietary control strategies that respond to a variety of conditions to maintain efficient operation
- Total chiller control through continuous monitoring

Visibility

- Full system status at a glance
- Clear display of key operating parameters

Ease of use

- The TD7 touch-screen 7" color display shows key operating parameters and allows quick access to critical data

- Intuitive navigation allows quick access to critical data
- Main processor in the control panel

Flexibility

- Thanks to open protocols such as BACnet®, LonTalk™ and Modbus

Operational effectiveness

- Data trending
- Clear alarm log enables fast response and rapid resolution
- TIS (Trane Intelligent Services) for remote data collection, analysis and recommendation
- Adaptive Control algorithms preempt chiller disruption



A world leading combination: the proven Tracer UC800 Controller and the all-new TD7 Interface.

RTHD^{evo} Water-Cooled Chillers

1 Easier to use

UC800 Trane Controller

Combined with market leading

TD7 Human Interface

- Touch-screen 7" color display
- Intuitive navigation through menus
- Effective operation, monitoring and management

Easier to install

- All versions and sizes fit through standard 2m wide doors
- Only one water connection on the condenser (inlet/outlet)
- Only one electrical connection (single point) as standard
- Saves time, saves costs

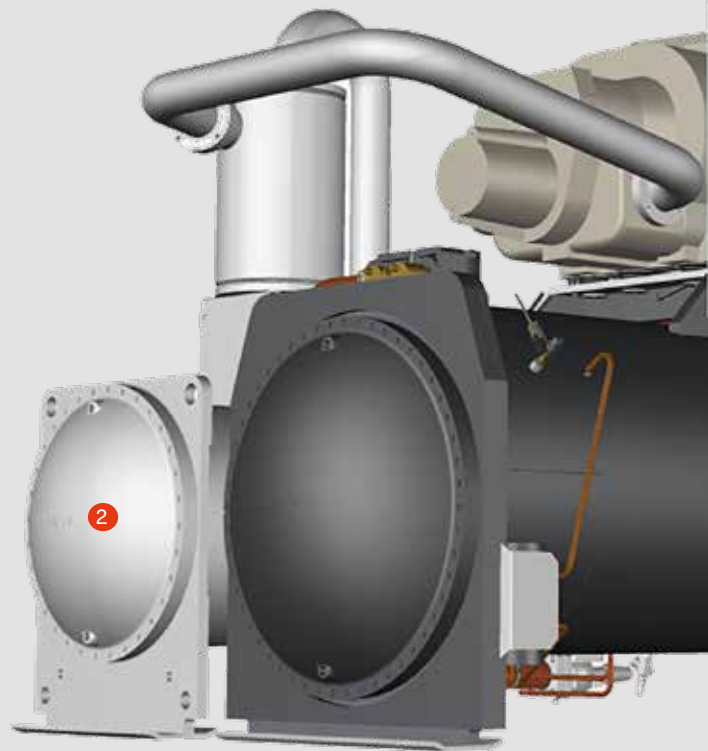

2 Proven Trane reliability

- Trane design simplicity
- Trane direct drive, low speed, semi-hermetic compressor with only 3 moving parts
- Infinite unloading for exact load matching
- RTHD^{evo} uses system differential to move oil, not an oil pump, meaning no extra moving parts to wear out or break down

5 Increased savings with HSE (High Seasonal Efficiency) version

- AFD (Adaptive Frequency Drive) as standard
- Fewer start-stop cycles
- Increased compressor life
- Reduced start-up current draw
- Optional harmonic filter to eliminate harmonic pollution

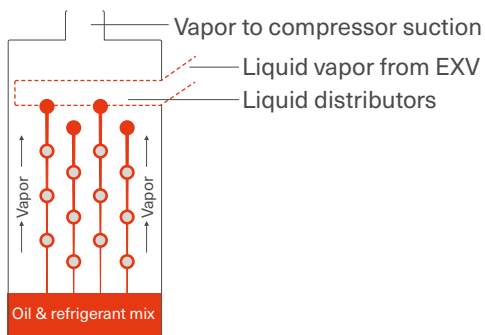

3 Maximum efficiency

- Patented Trane Falling Film Evaporator
- Industry leading efficiency
- Reduces energy bills

General specifications

Condenser leaving water temperature (min/max)	(°C)	20 / 50
Evaporator leaving water temperature (min/max)	(°C)	-12 / +18
Power supply	(V/Ph/Hz)	400/3/50

Standard Efficiency (SE)

Unit size		225 SE	250 SE	300 SE	325 SE	350 SE	375 SE
Net cooling capacity (1) (3)	(kW)	769	886	1049	1145	1216	1342
Net EER (1) (3)		5.16	5.03	5.03	5.18	5.06	4.81
Eurovent Energy class - Cooling		A	B	B	A	A	B
SEER (4)		5.88	6.00	5.43	5.73	5.75	5.18
Space cooling efficiency $\eta_{s,c}$ (4)	%	232	237	214	226	227	204
IPLV (2)		6.540	6.680	6.380	6.660	6.530	6.060
Sound power level (5)	(dB(A))	98	98	97	97	97	101
Weights and dimensions							
Length	(mm)	3290	3290	3290	3290	3290	3290
Width	(mm)	1600	1600	1600	1600	1600	1600
Height	(mm)	1940	1940	1940	1940	1940	1940
Operating weight	(kg)	5891	6833	6335	6522	6553	6655
Electrical data							
Unit-rated amps	(A)	349	349	455	455	455	488
Start-up amps (6)	(A)	480	480	748	748	748	748

High Efficiency (HE)

Unit size		150 HE	175 HE	225 HE	250 HE	300 HE	350 HE	375 HE	400 HE
Net cooling capacity (1) (3)	(kW)	545	595	778	896	1074	1196	1278	1411
Net EER (1) (3)		5.49	5.43	5.36	5.26	5.42	5.65	5.6	5.31
Eurovent Energy class - Cooling		A	A	A	A	A	A	A	A
SEER (4)		6.03	6.33	6.03	6.23	5.78	6.15	6.23	5.58
Space cooling efficiency $\eta_{s,c}$ (4)	%	238	250	238	246	228	243	246	220
IPLV (2)		6.780	6.940	6.700	6.860	6.700	7.120	6.970	6.520
Sound power level (5)	(dB(A))	98	98	98	98	97	97	97	101
Weights and dimensions									
Length	(mm)	3170	3170	3290	3290	3290	3690	3690	3690
Width	(mm)	1600	1600	1600	1600	1600	1600	1600	1600
Height	(mm)	1850	1850	1940	1940	1940	1940	1940	1940
Operating weight	(kg)	4361	4361	6030	6030	6612	7558	7589	7767
Electrical data									
Unit-rated amps	(A)	233	233	349	349	455	455	455	488
Start-up amps (6)	(A)	412	412	480	480	748	748	748	748

Extra-high Efficiency (XE)

Unit size		150 XE	175 XE	225 XE	275 XE	325 XE	350 XE	375 HE	425 XE
Net cooling capacity (1) (3)	(kW)	559	614	797	937	1119	1203	1294	1453
Net EER (1) (3)		5.69	5.69	5.68	5.86	5.94	5.88	5.94	5.73
Eurovent Energy class - Cooling		A	A	A	A	A	A	A	A
SEER (4)		6.18	6.63	6.48	6.73	6.28	6.35	6.48	5.95
Space cooling efficiency $\eta_{s,c}$ (4)	%	244	262	256	266	248	251	256	235
IPLV (2)		6.980	7.220	6.920	7.320	7.160	7.230	7.100	6.800
Sound power level (5)	(dB(A))	98	98	98	98	97	97	97	101
Weights and dimensions									
Length	(mm)	3640	3640	3290	3670	3850	3850	3850	3850
Width	(mm)	1600	1600	1600	1600	1800	1800	1800	1800
Height	(mm)	1850	1850	1940	1940	2035	2040	2040	2040
Operating weight	(kg)	4756	4756	6355	6833	8951	9196	9384	9741
Electrical data									
Unit-rated amps	(A)	233	233	349	349	455	455	455	488
Start-up amps (6)	(A)	412	412	480	480	748	748	748	748

High Seasonal Efficiency (HSE)



Unit size		150 HSE	175 HSE	225 HSE	275 HSE	325 HSE	350 HSE	375 HSE	425 HSE
Net cooling capacity (1) (3)	(kW)	559	614	797	937	1119	1203	1294	1453
Net EER (1) (3)		5.51	5.50	5.50	5.67	5.75	5.69	5.75	5.55
Eurovent Energy class - Cooling		A	A	A	A	A	A	A	A
SEER (4)		7.55	7.93	7.78	8.45	8.60	8.08	8.83	8.28
Space cooling efficiency $\eta_{s,c}$ (4)	%	299	314	308	335	341	320	350	328
IPLV (2)		8.370	8.680	8.250	8.970	8.850	8.650	9.130	9.090
Sound power level (5)	(dB(A))	98	98	98	98	97	97	97	101
Weights and dimensions									
Length	(mm)	3640	3640	3290	3670	3850	3850	3850	3850
Width	(mm)	1690	1690	1810	1810	2000	2000	2000	2000
Height	(mm)	1850	1850	1970	1970	2040	2040	2040	2040
Operating weight	(kg)	4860	4860	6534	7012	9139	9384	9572	9929
Electrical data									
Unit-rated amps	(A)	218	218	314	314	421	421	421	452
Start-up amps	(A)	< I Max.	< I Max.	< I Max.	< I Max.	< I Max.	< I Max.	< I Max.	< I Max.

(1) Evaporator 12/7°C and 0.0 m²K/kW, and condenser at 30/35°C and 0.0 m²K/kW

(2) According to AHRI Standard 550/590, based on TOPSS (Trane Official Product Selection Software)

(3) Net performances calculated as per EN 14511-2013.

(4) $\eta_{s,c}$ / SEER as defined in Directive 2009/125/EC of the European Parliament and of the Council with regard to Ecodesign requirements for Comfort Chillers with 2000 kW maximum capacity - COMMISSION REGULATION (EU) N° 2016/2281 of 20 December 2016

(5) At full load and in accordance with ISO9614

(6) Inrush current in star/delta connection

The Trane advantage



Trane is recognized as a world leader with over **100 years of experience** in creating and sustaining safe, comfortable and energy efficient environments while improving the performance of buildings and processes around the world.

Trane innovative solutions optimize indoor environments with the **broadest portfolio** of energy efficient heating, ventilating and air conditioning systems, building services, parts support and advanced controls in the industry.

To ensure your equipment continues to work at its optimum, throughout the life of the building, Trane provides a full range of service solutions, combined with in-house expertise and the **most extensive service and support network** in the industry.

And with Trane's **extensive rental fleet** all your temporary cooling and heating needs are served: we provide continuous cooling or heating during equipment changeouts or supplemental supply for those times when your cooling loads exceed your current system's capacity. For more information: www.trane-chiller-rental.eu



Trane – by Trane Technologies (NYSE: TT), a global climate innovator – creates comfortable, energy efficient indoor environments through a broad portfolio of heating, ventilating and air conditioning systems and controls, services, parts and supply. For more information, please visit trane.eu or tranetechnologies.com.