



Installation Operation Maintenance

CGAF Air-Cooled Scroll Chillers
CXAF Air to Water Scroll Heat Pumps
260 - 710 kW
R410A - R454B Refrigerant



June 2023

CG-SVX039E-GB



Confidential and proprietary Trane information
Original instructions



Table of Contents

General Information	3
Unit Description	5
Unit Model Number Description	6
Pre-Installation	8
General Data	10
Table 1 – General data CGAF 090-190 Standard Efficiency.....	10
Table 2 – General data CGAF 080-190 High Efficiency	13
Table 3 – General data CGAF 080-190 Extra Efficiency	16
Table 4 – General data CGAF 090-150 Standard Efficiency – Shell & Tube (R410A)	19
Table 5 – General data CXAF 080-110 Standard Efficiency.....	22
Table 6 – General data CXAF 130-190 Standard Efficiency.....	25
Table 7 – General data CXAF 080-110 High Efficiency	28
Table 8 – General data CXAF 130-190 High Efficiency	31
Typical CGAF / CXAF Components location	34
Installation Requirements	37
Evaporator Piping	39
Installation - Mechanical	42
Schematic pump package	43
Evaporator Waterside	47
General Electrical Recommendations	50
Installer-Supplied Components	52
Operating Principles	53
Operating Map	58
Total Heat Recovery	61
Table 9 – General Data for Total Heat recovery (THR) Option CGAF 080-190.....	61
Table 10 – Operating Map (THR) CGAF 080-190.....	62
When a total heat recovery is installed, refrigerant charge (kg) are as shown in the table below.	63
Table 11 – Refrigerant Charge (THR Option) CGAF 080-190.....	63
Partial Heat Recovery Option	65
Table 12/13/14 – General data for Partial Heat Recovery CGAF 080-190 SE/HE/XE	66
Optional Free-Cooling	68
Table 15 – General Data for Partial Heat recovery CXAF 080-190 Standard Efficiency.....	68
Table 16 – General Data for Partial Heat recovery CXAF 080-190 High Efficiency.....	68
Table 17 – General data for free cooling option sizes 080-190	69
Operating Principles	73
Option Free-Cooling	74
Controls/Tracer TD7 Operator Interface	77
Compressor Service Information	85
Condenser Coils MCHE Maintenance	87
Integrated Pump Maintenance	89
BPHE Evaporator Maintenance	90
Log Check Sheet	91
Recommended Service Routine Frequencies	92
Additional Services	93

General Information

Foreword

These instructions are given as a guide to good practice in the installation, start-up, operation, and maintenance by the user, of Trane CGAF - Chillers and CXAF – Heat Pumps manufactured in France.

A separate manual is available for the use and maintenance of the unit's control, Tracer™ UC800/ Symbio800. They do not contain full service procedures necessary for the continued successful operation of this equipment. The services of a qualified technician should be employed through the medium of a maintenance contract with a reputable service company. Read this manual thoroughly before unit start-up.

Note: All the Chiller / Heat Pump Units are assembled, pressure tested, dehydrated, charged and tested in accordance with factory standard before shipment.

Warnings and Cautions

Warnings and Cautions appear at appropriate sections throughout this manual. Your personal safety and the proper operation of this machine require that you follow them carefully. The constructor assumes no liability for installations or servicing performed by unqualified personnel.

WARNING: Indicates a potentially hazardous situation which, if not avoided, could result in death or serious injury.

CAUTION: Indicates a potentially hazardous situation which, if not avoided, may result in minor or moderate injury. It may also be used to alert against unsafe practices or for equipment or property-damage-only accidents.

Safety Recommendations

To avoid death, injury, equipment or property damage, the recommendation contains in the IOM addendum (PROD-SVX01) should be observed during commissioning, start-up, maintenance and service visit.

The following pictograms can be found on the unit and detailed in the IOM addendum (PROD-SVX01). Take necessary precautions to avoid damage and injury.

Figure 1 – Warning pictograms



- 1 = Risk that unit is powered up
- 2 = Risk hazard due to fan rotation
- 3 = Risk hazard of burns on compressors or refrigeration piping
- 4 = Unit contains refrigerant gas. See specific warnings.
- 5 = Risk of residual voltage when speed drive, capacitor or softstarter options are present
- 6 = Unit under pressure
- 7 = Risk to cut, particularly on heat exchanger fins
- 8 = For R454B, risk of fire and flammable material
- 9 = Disconnect all electric power before servicing
- 10 = Read technical instructions
- 11 = Read instructions before installation

Reception

On arrival,

- Inspect the unit before signing the delivery note.
- Specify any visible damage on the delivery note.
- Notify the local TRANE sales office at the same time.

Note: The delivery note must be clearly signed after inspection and countersigned by the driver.

Also send a registered letter of protest to the last carrier of the goods within 7 days of delivery.

Concealed damage also shall be notified by a registered letter of protest to the last carrier of the goods within 7 days of delivery. Notify the local TRANE sales office at the same time.

Important notice: No shipping claims will be accepted by TRANE if the above mentioned procedure is not respected.

For more information, refer to the general sales conditions of your local TRANE sales office.

Note: For units delivered in France, the scheduled time for unit inspection and notifying through registered letter in case of visible and concealed damage is only 72 hours.



General Information

Loose Parts Inventory

Check all the accessories and loose parts that are shipped with the unit against the shipping list. Included in these items will be the water vessel drain-plugs, rigging and electrical diagrams, service literature, which are placed inside the control panel and/or starter panel for shipment. If optional elastomeric isolators are ordered with the unit, they are shipped mounted on the horizontal support frame of the chiller/heat pump. The isolators' location and distribution weight diagram is placed with the service literature inside the starter/control panel.

Warranty

Warranty is based on the general terms and conditions of the manufacturer. The warranty is void if the equipment is repaired or modified without the written approval of the manufacturer, if the operating limits are exceeded or if the control system or the electrical wiring is modified. Damage due to misuse, lack of maintenance, or failure to comply with the manufacturer's instructions or recommendations is not covered by the warranty obligation. If the user does not conform to the rules of this manual, it may entail the cancellation of warranty and liabilities by the manufacturer.

Startup **MUST** be performed by Trane, or an authorized agent of Trane, to **VALIDATE** this **WARRANTY**.

Maintenance Contract

It is strongly recommended that you sign a maintenance contract with your local Service Agency.

This contract provides regular maintenance of your installation by a specialist in our equipment. Regular maintenance ensures that any malfunction is detected and corrected in good time and minimizes the possibility that serious damage will occur. Finally, regular maintenance ensures the maximum operating life of your equipment. We would remind you that the failure to respect these installation and maintenance instructions may result in the immediate cancellation of the warranty.

Training

To assist you in obtaining the best use of it and maintaining it in perfect operating condition over a long period of time, the manufacturer has at your disposal a refrigeration and air conditioning service school. The principal aim of this is to give operators and technicians a better knowledge of the equipment they are using, or that is under their charge. Emphasis is particularly given to the importance of periodic checks on the unit operating parameters as well as on preventive maintenance, which reduces the cost of owning the unit by avoiding serious and costly breakdown.

Refrigerant

The refrigerant provided by the manufacturer meets all the requirements of our units. When using recycled or reprocessed refrigerant, it is advisable to ensure its quality is equivalent to that of a new refrigerant. For this, it is necessary to have a precise analysis made by a specialized laboratory. If this condition is not respected, the manufacturer warranty could be cancelled.



Unit Description

Sintesis Advantage Chillers CGAF and Heat pumps CXAF are air-cooled scroll compressor units designed for outdoor installation. The CGAF units are cooling only units and CXAF units are reversible and can work in cooling and heating mode.

The units have two independent refrigerant circuits, two or three compressors per circuit. Units are packaged with an evaporator and condenser.

Each unit is completely assembled, hermetic packaged, refrigerant circuit factory piped, electrical components wired, leak tested, dehydrated, charged and tested.

The chilled water inlet and outlet openings are covered for shipment.

Units feature Trane's exclusive Tracer™ UC800/ Symbio800 Control logic and controls. It monitors the control variables that govern the operation of the unit. Control logic can correct these variables when necessary to optimize operational efficiencies, to avoid the unit shut down, and keep producing the chilled or hot water.

These units come with various options and can be customized depending on capacity, efficiencies, acoustic levels, application requirements at the time of order placement.

The unit received and its options can be cross-checked with the serial and model number provided in unit nameplate and description provided under unit model number description provided in the manual.

Nameplates

The CGAF / CXAF outdoor unit nameplates are applied to the exterior of the control panel. A compressor nameplate is located on each compressor.

Unit Nameplate

The unit nameplate provides the following information:

- Unit model and size description
- Unit serial number
- Identifies unit electrical requirements
- Lists correct operating charges of refrigerant and refrigerant oil
- Lists unit test pressures

Compressor Nameplate

The compressor nameplate provides following information:

- Compressor model number.
- Compressor serial number.
- Compressor electrical characteristics.
- Utilization range.
- Recommended refrigerant.



Unit Model Number Description

Digit 1, 2, 3, 4 – Unit Model

CGAF = Air-Cooled Scroll – Chiller
CXAF = Air-Cooled Scroll – Heat Pump

Digit 5-7 – Unit Nominal Tonnage

080 = 80 Tons
090 = 90 Tons
100 = 100 Tons
110 = 110 Tons
130 = 130 Tons
140 = 140 Tons
150 = 150 Tons
165 = 165 Tons
180 = 180 Tons
190 = 190 Tons

Digit 8 – Unit Voltage

D = 400V/50Hz/3ph
G = 400V/50Hz/3ph Compatible with IT Neutral

Digit 9 – Manufacturing Location

E = Epinal
F = Epinal (ICS)

Digit 10, 11 – Design Sequence

** = Factory assigned

Digit 12 – Efficiency

A = Extra Efficiency
H = High Efficiency (With SLHX), 4V/5V/6V
N = Standard Efficiency, 4V/5V/6V
R = High Heat Efficiency, 4V/5V/6V
U = Standard Efficiency (Compact), 3V
V = High Efficiency (Compact, with SLHX), 3V
W = High Heat Efficiency (Compact), 3V

Digit 13 – Agency Listing

C = CE Certification (EUR)
U = UKCA Marking

Digit 14 – Pressure Vessel Code

2 = PED (Pressure equipment directive)

Digit 15 – Acoustic Level

X = Standard Noise (SN)
L = Low Noise (LN)
E = Extra Low Noise (XLN)

Digit 16 – Unit Application

X = Standard Ambient [-10°C; 46°C]
L = Low Ambient [-20°C; 46°C]
H = High Ambient [-10°C; 52°C]
D = Wide Ambient [-20°C; 52°C]
1 = Comfort application, cooling mode [10°C; 46°C] and heating mode [-15°C; 20°C]
3 = Process application, cooling mode [-20°C; 46°C] Heating mode [-15°C; 35°C]

Digit 17 – Relief Valve Option

W = Without

Digit 18 – Water Connection

X = Grooved pipe connection
W = Grooved pipe + welded coupling
2 = Grooved pipe with coupling and flange adapter

Digit 19 – Evaporator Application

N = Standard cooling [4°C; 20°C]
P = Process cooling [-12°C; 4°C]
C = Ice making [-7°C; 20°C] with hardwired interface

Digit 20 – Evaporator Configurations

B = Brazed plate heat exchanger
T = Shell & Tube heat exchanger

Digit 21 – Thermal Insulation

N = Standard

Digit 22 – Condenser Coating

N = Aluminium Micro Channel
C = E-Coated Micro Channel
B = Aluminium Hydrophilic (blue) coating
E = Epoxy Coated Aluminium Fins (gold)

Digit 23 – Heat Recovery

X = No Heat Recovery
P = Partial Heat Recovery
T = Total Heat Recovery (full equipment)

Digit 24 – Hydraulic Module

X = Pump signal On/Off
1 = Dual pump standard pressure
2 = Single pump standard pressure
3 = Dual pump high pressure
4 = Single pump high pressure

Digit 25 – Free-Cooling

X = No Free-Cooling
F = Total Free-Cooling Direct
H = Total Free-Cooling Glycol free

Digit 26 – Disconnect Switch

B = With circuit breaker

Digit 27 – Under/Over Voltage

X = None
1 = Included
2 = Included with ground fault protection

Digit 28 – Human Interface language

C = Spanish
D = German
E = English
F = French
H = Dutch
I = Italian
M = Swedish
P = Polish
R = Russian
T = Czech
U = Greek
V = Portuguese
2 = Romanian
6 = Hungarian
8 = Turkish

Digit 29 – Smart Com Protocol

X = None motor interface
B = BACnet MS/TP interface
M = ModBus RTU interface
L = LonTalk interface
C = BACnet TCP/IP interface
N = ModBusTCP interface

Digit 30 – Communication Customer

X = None
A = External set point & capacity outputs



Unit Model Number Description

Digit 31 – Flow Switch

X = None
F = Field installed flow switch

Digit 32 – Electrical Panel Protection

X = Enclosure with deadfront protection
1 = Enclosure with IP 20 internal protection

Digit 33 – Master Slave

X = Without
A = With

Digit 34 – Unit User Interface

L = Standard, Local UI supplied (TD7)

Digit 35 – Energy Meter

X = No energy meter
M = Energy meter installed

Digit 36 – Mini Chiller Plant Control

X = No Mini PC

Digit 37 – Variable Primary Flow

X = Constant speed pump (No VFD)
A = Pump flow controlled by 3 ways valve
F = Constant Speed Pump -VFD Adjustment
P = Variable Speed Pump - Constant delta P
T = Variable Speed Pump - Constant delta T

Digit 38 – Refrigeration Leak Detection

X = Not installed
V = Installed

Digit 39 – Web Server

X = Not installed

Digit 40 – Power Socket

X = None
P = Included (230V - 100W)

Digit 41 – Factory Tests

X = None
B = Visual inspection with Customer
C = Performance Test with Customer: 1 Point
D = Performance Test with Customer: 2 Points
E = Performance Test without Customer: 1 Point
S = Special

Digit 42 – Installation Accessory

X = None
1 = Neoprene Isolators
4 = Neoprene Pads

Digit 43 – Literature Language

B = Bulgarian
C = Spanish
D = German
E = English
F = French
H = Dutch
I = Italian
K = Finnish
L = Danish
M = Swedish
N = Norwegian
P = Polish
R = Russian
T = Czech
U = Greek

V = Portuguese

Z = Slovenian

2 = Romanian

3 = Serbian

4 = Slovak

5 = Croatian

6 = Hungarian

8 = Turkish

Digit 44 – Shipping Package

X = Standard protection
A = Containerization package

Digit 45 – Refrigerant

2 = Charge nitrogen (N2) for R410A units

A = Full factory refrigerant charge R410A

8 = Factory pre-charge refrigerant R410A

3 = Charge nitrogen (N2) for R454B units

B = Full factory refrigerant charge R454B

9 = Factory pre-charge refrigerant R454B

Digit 46 – Isolator Valve Per Manifold Compressor

X = None

A = With

Digit 47 – Power Factor Correction Capacitors

A = With

X = None

Digit 48 – Open for Future Use = X

Digit 49 – Freeze Protection (Factory Installed)

X = None

2 = With freeze protection

Digit 50 – Buffer Tank

X = No Tank

1 = With Tank

2 = With Buffer Tank-Compatible with Auxiliary Electric Heater

Digit 51 – Water Strainer

X = No strainer

A = Factory installed strainer

Digit 52 – Louvered Panels

X = None

A = Architectural louvered panels

Digit 53 – Open for Future Use = X

Digit 54 – Starter Type

A = Across the line starter/Direct On Line

B = Soft starter

Digit 55 – Annunciation Relay

X = None

A = With

Digit 56 – Fan Type

1 = AC fan

2 = EC fan

3 = EC HESP

Digit 57 – Night Noise Setback (NNSB)

X = Without

1 = With NNSB

Digit 58 – Design Special

X = Standard

S = Special requirement



Pre-Installation

Inspection Checklist

When the unit is delivered, verify that it is the correct unit and that it is properly equipped. Compare the information which appears on the unit nameplate with the ordering and submittal information.

Inspect all exterior components for visible damage. Report any apparent damage or material shortage to the carrier and make a "unit damage" notation on the carrier's delivery receipt. Specify the extent and type of damage found and notify the appropriate Trane Sales Office. Do not proceed with installation of a damaged unit without sales office approval.

Mandatory Start-up Checklist

This checklist is not intended to be a substitution for the contractor's installation instruction. This checklist is intended to be a guide for the Trane technician just prior to unit 'start-up'. Many of the recommended checks and actions could expose the technician to electrical and mechanical hazards. Refer to the appropriate sections in the unit manual for appropriate procedures, component specifications and safety instructions.

Except where noted; it is implied that the technician is to use this checklist for inspection/verification of prior tasks completed by the general contractor at installation.

1. Unit clearances adequate for service and to avoid air recirculation, etc.
2. Unit exterior inspected. CGAF/CXAF condenser coil will not be obstructed at any time by snow or ice during winter conditions
3. Unit properly grounded
4. Crankcase heaters working for 24 hours prior to arrival of Trane technician performing start-up
5. Correct voltage supplied to unit and electric heaters (imbalance not to exceed 2%)
6. Unit power phasing (A-B-C sequence) proper for compressor rotation
7. Copper power wiring meets sizing requirement in job submittal
8. All automation and remote controls installed/wired
9. All wiring connections tight
10. Prove chilled water side Interlock and Interconnecting
11. Wiring Interlock and externals (chilled water pump)
12. Field installed control wiring landed on correct terminals (external start/stop, emergency stop, chilled water reset...)

13. Verify all refrigerant and oil valves are open/back seated
14. Compressor oil levels (1/2 -3/4 high in glass) proper
15. Verify chilled water strainer is clean and free of debris and evaporator chilled water circuits are filled
16. A pressure switch device to detect lack of water is not included in the pump package. Installation of this type of device is highly recommended to avoid sealing damage due to operation of pump without enough water
17. Close the fused-disconnect switches that supplies power to the chilled water pump starter
18. Start the chilled water pump to begin circulation of the water. Inspect piping for leaks and repair as necessary. Check the physical presence of the water pressure switch
19. With water circulating through the system, adjust water flow and check water pressure drop through evaporator
20. Return chilled water pump to auto
21. Verify all the chiller controller Menu Items
22. All panels/doors secured prior to start-up
23. All coil fins inspected and straightened
24. Rotate fans before starting unit to inspect for potential audible and visual signs of rubbing. Start unit
25. Press AUTO key. The unit will start if the chiller control calls for cooling and the safety interlocks are closed
26. Check the evaporator and the condenser refrigerant pressure on the chiller controller
27. Confirm Superheat and sub-cooling values are normal
28. Compressor operation normal and within amperage rating
29. Operating log completed
30. Press stop key
31. Inspect fans again after being under load to ensure no signs or rubbing exist
32. Verify the chilled water pump runs for at least 1 minute (possibility to configure max of 10 mins) after the chiller is commanded to stop (for normal chilled water systems)

Unit Storage

If the chiller is to be stored for more than one month prior to installation, observe the following precautions:

- Store the unit in a secured area, to avoid intentional damages.
- Close the suction, discharge and liquid-line isolation valves.



Pre-Installation

- Store the chiller in a dry, vibration-free, secure area.
- At least every three months, attach a gauge and manually check the pressure in the refrigerant circuit.
- If the refrigerant pressure is below 13 bar (R410A)/ 12.5 bar (R454B) at 20°C {or 10 bar (R410A)/ 9.5 bar (R454B) at 10°C}, call a qualified service organization and the appropriate Trane sales office.

Note: If the unit is stored before servicing near a construction site it is highly recommended to protect micro channel coils from any concrete and iron element. Failure to do so may considerably reduce reliability of the unit.

Installation requirements and contractor responsibilities

A list of the contractor responsibilities typically associated with the unit installation process is provided.

Type of requirement	Trane-supplied Trane-installed	Trane-supplied Field-installed	Field-supplied Field-installed
Foundation			<ul style="list-style-type: none"> • Meet foundation requirements
Rigging			<ul style="list-style-type: none"> • Safety chains • Clevis connectors • Lifting beams
Isolation		<ul style="list-style-type: none"> • Neoprene Pads • Isolators (Optional) 	<ul style="list-style-type: none"> • Neoprene Pads • Isolators (Customer Supplied)
Electrical	<ul style="list-style-type: none"> • Disconnect Switch • Unit mounted starter 		<ul style="list-style-type: none"> • Wiring sizes per submittals and local codes and regulations • Terminal lugs • Ground connection(s) • BAS Wiring (optional) • Control voltage wiring • Chilled water pump contactor and wiring including interlock • Option relays and wiring
Water piping	<ul style="list-style-type: none"> • Flow Switch • Water Strainer (Optional) 		<ul style="list-style-type: none"> • Taps for thermometers and gauges • Thermometers • Water flow pressure gauges • Isolation and balancing valves in water piping • Vents and drains • Pressure relief valves • Pressure switch device to detect lack of water
Insulation	<ul style="list-style-type: none"> • Insulation 		<ul style="list-style-type: none"> • Insulation (Piping)
Water piping connection elements	<ul style="list-style-type: none"> • Grooved pipe 	<ul style="list-style-type: none"> • Grooved pipe couplings (or) Flanged Adapters 	
Leak detector		<ul style="list-style-type: none"> • Leak detector is supplied by Trane and Wired by contractor 	



General Data

Table 1 – General data CGAF 090-190 Standard Efficiency

		CGAF 90 SE	CGAF 100 SE	CGAF 110 SE	CGAF 130 SE	CGAF 140 SE	CGAF 150 SE	CGAF 165 SE	CGAF 180 SE	CGAF 190 SE
Net Cooling Capacity For R410A (1)	(kW)	324.1	355.2	397.8	441.0	491.0	524.9	567.8	632.5	676.1
Net Total Power input For R410A (1)	(kW)	103.0	117.3	135.1	153.8	164.2	179.5	198.1	207.1	225.0
Unit electrical data (2) (3) (4)										
Short Circuit Unit Capacity	(kA)	15	15	15	15	15	15	15	15	15
Power Cable Cross Section (max)	mm ²	1*240	1*240	1*240	1*240	2*300	2*300	2*300	2*300	2*300
Disconnect switch size	(A)	400	400	500	500	630	630	630	800	800
Digit 56=1										
Maximum Power input	(kW)	142.0	161.1	175.3	189.5	220.8	240.0	254.2	271.2	285.4
Max. amps	(A)	233.4	261.9	289.7	317.5	360.6	389.1	416.9	450.3	478.0
Unit start up amps (w/o soft starter - digit 54=A) (4)	(A)	466.6	495.1	628.0	655.8	593.8	622.3	755.2	788.6	816.4
Unit start up amps (with soft starter - Digit 54=B) (4)	(A)	349.0	377.5	462.8	490.6	476.2	504.7	590.0	623.4	651.2
Displacement power factor	(dpf)	0.88	0.89	0.87	0.86	0.88	0.89	0.88	0.87	0.86
Digit 56=2										
Maximum Power input	(kW)	142.9	162.0	176.2	190.4	222.0	241.2	255.4	272.7	286.9
Max. amps	(A)	231.6	260.1	287.9	315.7	358.2	386.7	414.5	447.3	475.0
Unit start up amps (w/o soft starter - Digit 54=A) (4)	(A)	464.8	493.3	626.2	654.0	591.4	619.9	752.8	785.6	813.4
Unit start up amps (with soft starter - Digit 54=B) (4)	(A)	347.2	375.7	461.0	488.8	473.8	502.3	587.6	620.4	648.2
Displacement power factor	(dpf)	0.89	0.90	0.88	0.87	0.89	0.90	0.89	0.88	0.87
Digit 56=3										
Maximum Power input	(kW)	144.5	163.6	177.9	192.1	224.2	243.3	257.6	275.4	289.6
Max. amps	(A)	234.0	262.5	290.3	318.1	361.4	389.9	417.7	451.3	479.0
Unit start up amps (w/o soft starter - Digit 54=A) (4)	(A)	467.2	495.7	628.6	656.4	594.6	623.1	756.0	789.6	817.4
Unit start up amps (with soft starter - Digit 54=B) (4)	(A)	349.6	378.1	463.4	491.2	477.0	505.5	590.8	624.4	652.2
Displacement power factor (dpf)	(dpf)	0.89	0.90	0.88	0.87	0.90	0.90	0.89	0.88	0.87
Compressor										
Compressor Number per Circuit	#	2	2	2	2	3	3	3	3	3
Type		Scroll	Scroll	Scroll	Scroll	Scroll	Scroll	Scroll	Scroll	Scroll
Model Circuit 1 / Circuit 2	kW	25+30/ 25+30	30+30/ 30+30	30+40/ 30+40	40+40/ 40+40	25+30+30/ 25+30+30	30+30+30/ 30+30+30	30+30+40/ 30+30+40	30+40+40/ 30+40+40	40+40+40/ 40+40+40
Max Comp Power input Circuit 1 / Circuit 2	kW	28.4+38.2/ 28.4+38.2	38.2+38.2/ 38.2+38.2	38.2+45.2/ 38.2+45.2	45.2+45.2/ 45.2+45.2	28.4+38.2 +38.2/28.4	38.2+38.2 +38.2/38.2	38.2+38.2 +45.2/38.2	38.2+45.2 +45.2/38.2	45.2+45.2 +45.2/45.2
Rated Amps Circuit 1 / Circuit 2	(A)	47+61/ 47+61	61+61/ 61+61	61+75/ 61+75	75+75/ 75+75	47+61 +61/47 +61+61	61+61 +61/61 +61+61	61+61 +75/61 +61+75	61+75 +75/61 +75+75	75+75 +75/75 +75+75
Locked Rotor Amps Circuit 1 / Circuit 2 (direct start - Digit 54=A)	(A)	260+294/ 260+294	294+294/ 294+294	294+413/ 294+413	413+413/ 413+413	260+294 +294/260 +294+294	294+294 +294/294 +294+294	294+294 +413/294 +294+413	294+413 +413/294 +413+413	413+413 +413/413 +413+413
Locked Rotor Amps Circuit 1 / Circuit 2 (Soft starter - Digit 54=B)	(A)	156+176/ 156+176	176+176/ 176+176	176+248/ 176+248	248+248/ 248+248	156+176 +176/156 +176+176	176+176 +176/176 +176+176	176+176 +248/176 +176+248	176+248 +248/176 +248+248	248+248 +248/248 +248+248
Motor RPM	(rpm)	2900	2900	2900	2900	2900	2900	2900	2900	2900
Oil sump heater Circuit 1 / Circuit 2	(W)	90+90/ 90+90	90+90/ 90+90	90+90/ 90+90	90+90/ 90+90	90+90+90/ 90+90+90	90+90+90/ 90+90+90	90+90+90/ 90+90+90	90+90+90/ 90+90+90	90+90+90/ 90+90+90
Evaporator										
Quantity	#	1	1	1	1	1	1	1	1	1
Type		Stainless steel Copper Brazed plate Heat exchanger								
Evaporator model		DFX650x106	DFX650x122	DFX650x138	DFX650x166	DFX650x166	DFX650x194	DFX650x222	DFX650x250	DFX650x278
Evaporator Water Content volume	(l)	31	35.7	40.4	48.6	48.6	56.7	64.9	73.1	81.3
Nominal water connection size (Grooved coupling) - Without HYM	(in) - (mm)	4" -114.3	4" -114.3	4" -114.3	4" -114.3	5" -139.7	5" -139.7	5" -139.7	5" -139.7	5" -139.7
Nominal water connection size (Grooved coupling) - With HYM	(in) - (mm)	4" -114.3	4" -114.3	4" -114.3	4" -114.3	5" -139.7	5" -139.7	5" -139.7	5" -139.7	5" -139.7
Hydraulic Module Components										
Single pump - Standard head pressure option										
Max available Head Pressure	(kPa)	123	115	98	92	142	137	124	164	155
Motor Power	(kW)	5.5	5.5	7.5	7.5	7.5	7.5	11	11	11

General Data

Table 1 – General data CGAF 090-190 Standard Efficiency (continued)

		CGAF 90 SE	CGAF 100 SE	CGAF 110 SE	CGAF 130 SE	CGAF 140 SE	CGAF 150 SE	CGAF 165 SE	CGAF 180 SE	CGAF 190 SE
Rated Amps	(A)	11	11	14.4	14.4	14.4	14.4	20.8	20.8	20.8
Single pump - High head pressure option										
Max available Head Pressure	(kPa)	251	247	234	232	249	252	245	234	226
Motor Power	(kW)	11	11	11	11	15	15	15	15	15
Rated Amps	(A)	20.8	20.8	20.8	20.8	28	28	28	28	28
Twin pump - Standard head pressure option										
Max available Head Pressure	(kPa)	123	115	98	92	142	137	124	164	155
Motor Power	(kW)	5.5	5.5	7.5	7.5	7.5	7.5	11	11	11
Rated Amps	(A)	11	11	14.4	14.4	14.4	14.4	20.8	20.8	20.8
Twin pump - High head pressure option										
Max available Head Pressure	(kPa)	251	247	234	232	249	252	245	234	226
Motor Power	(kW)	11	11	11	11	15	15	15	15	15
Rated Amps	(A)	20.8	20.8	20.8	20.8	28	28	28	28	28
Expansion Tank Volume	(l)	50	50	50	50	50	50	50	50	50
Max User water loop Volume for factory mounted expansion tank (1)	(l)	1750	1750	1750	1750	1750	1750	1750	1750	1750
Optional water Buffer tank volume	(l)	607	607	607	607	777	777	777	777	777
Antifreeze Heater without pump package and without buffer tank	(W)	360	420	420	420	540	640	640	640	640
Antifreeze Heater with pump package and without buffer tank (Single Water Pump digit 24=2 or 4 / Dual Water Pump digit 24=1 or 3)	(W)	1000 / 1060	1060 / 1120	1060 / 1120	1060 / 1120	1240 / 1300	1340 / 1400	1340 / 1400	1340 / 1400	1340 / 1400
Antifreeze Heater with pump package and with buffer tank (Single Water Pump digit 24=2 or 4 / Dual Water Pump digit 24=1 or 3)	(W)	1880 / 1940	1940 / 2000	1940 / 2000	1940 / 2000	2690 / 2750	2790 / 2850	2790 / 2850	2790 / 2850	2790 / 2850
Condenser										
Type		Full aluminium Micro channel heat exchanger								
Quantity of coil	#	6	6	6	6	8	8	8	10	10
Face area per circuit	(m ²)	8.88	8.88	8.88	8.88	11.84	11.84	11.84	14.8	14.8
Condenser Fan										
Quantity	#	6	6	6	6	8	8	8	10	10
Diameter	(mm)	800								
Fan / motor Type		Propeller fan : Fixed speed AC motor / Variable speed EC motor								
Digit 56=1										
Fan / motor Type		Fixed speed AC motor								
Airflow per fan	m ³ /h	17118	17037	16935	16830	17005	16943	16865	16984	16921
Max Power Input per Motor	Kw	1.4	1.4	1.4	1.4	1.4	1.4	1.4	1.4	1.4
Max Amps per Motor	A	2.8	2.8	2.8	2.8	2.8	2.8	2.8	2.8	2.8
Motor RPM	(rpm)	900	900	900	900	900	900	900	900	900
Digit 56=2										
Fan / motor Type		Variable speed EC small motor								
Airflow per fan	m ³ /h	17275	17197	17768	18558	17389	18221	19038	18038	18646
Max Power Input per Motor	Kw	1.55	1.55	1.55	1.55	1.55	1.55	1.55	1.55	1.55
Max Amps per Motor	A	2.5	2.5	2.5	2.5	2.5	2.5	2.5	2.5	2.5
Motor RPM (SN - LN)	(rpm)	840	840	870	910	850	890	930	880	910
Motor RPM (XLN)	(rpm)	830	830	830	830	830	830	830	830	830
Digit 56=3										
Fan / motor Type		Variable speed EC strong motor								
Airflow per fan	m ³ /h	18872	18792	19434	20814	19008	20431	21344	19976	20904
Max Power Input per Motor	Kw	1.82	1.82	1.82	1.82	1.82	1.82	1.82	1.82	1.82
Max Amps per Motor	A	2.9	2.9	2.9	2.9	2.9	2.9	2.9	2.9	2.9
Motor RPM (SN - LN)	(rpm)	830	830	860	920	840	900	940	880	920
Motor RPM (XLN)	(rpm)	780	780	780	780	780	780	780	780	780
Motor RPM (XLN)	(rpm)	800	800	800	800	800	800	800	800	800
Dimensions										
Unit Length	(mm)	3395	3395	3395	3395	4520	4520	4520	5645	5645
Unit Width	(mm)	2200	2200	2200	2200	2200	2200	2200	2200	2200
Std Unit Height	(mm)	2526	2526	2526	2526	2526	2526	2526	2526	2526



General Data

Table 1 – General data CGAF 090-190 Standard Efficiency (continued)

		CGAF 90 SE	CGAF 100 SE	CGAF 110 SE	CGAF 130 SE	CGAF 140 SE	CGAF 150 SE	CGAF 165 SE	CGAF 180 SE	CGAF 190 SE
Pump Package Option - (Additional length configuration)	(mm)	562	562	562	562	562	562	562	562	562
Weights										
Shipping Weight (3)	(kg)	2085	2200	2260	2325	2825	3005	3070	3435	3505
Option Additional shipping weight										
Single pump - Standard head pressure	(kg)	215	220	225	225	230	230	295	310	305
Single pump - High head pressure	(kg)	260	265	265	260	305	305	305	320	320
Twin pump - Standard head pressure	(kg)	300	305	325	320	325	325	440	450	450
Twin pump - High head pressure	(kg)	385	390	385	385	460	460	465	480	475
XLN option	(kg)	115	115	115	115	150	150	150	150	150
Pump VFD option	(kg)	70	70	70	70	70	70	70	70	70
Partial heat recovery option (Digit 19 = N)	(kg)	45	45	65	65	75	75	75	75	75
Partial heat recovery option (Digit 19 = P)	(kg)	45	45	45	45	75	75	75	75	75
Water Buffer tank option	(kg)	250	250	250	250	330	330	330	330	330
System data										
Nb of refrigerant circuit	#	2	2	2	2	2	2	2	2	2
Minimum cooling load % (6)	%	23	25	21	25	15	17	15	14	17
Total number of capacity steps	#	8	4	8	4	14	6	14	14	6
Standard/Partial Heat Recovery Unit										
R410A refrigerant charge Circuit 1 / Circuit 2	(kg)	18 / 18	19 / 19	19.5 / 19.5	20.5 / 20.5	30 / 30	32 / 32	33 / 33	38 / 38	39 / 38
R454B refrigerant charge Circuit 1 / Circuit 2	(kg)	15 / 15	16 / 16	16 / 16	17 / 17	25 / 25	26.5 / 26.5	27.5 / 27.5	31.5 / 31.5	32.5 / 31.5
Oil charge Circuit 1 / Circuit 2	(l)	14.2 / 14.2	14.2 / 14.2	14.2 / 14.2	14.2 / 14.2	22.1 / 22.1	22.3 / 22.3	22.3 / 22.3	22.3 / 22.3	22.3 / 22.3
Oil charge Circuit 1 / Circuit 2	(l)	16.2 / 16.2	16.2 / 16.2	16.2 / 16.2	16.2 / 16.2	24.1 / 24.1	24.3 / 24.3	24.3 / 24.3	24.3 / 24.3	24.3 / 24.3
POE Oil type		OIL058E / OIL057E								

(1) Indicative performance at Evaporator water temperature : 12°C / 7°C - Condenser air temperature 35°C - for detailed performances, on a given unit, consult Order Write Up.

With R454B refrigerant the Capacity/Power input may be reduced by 3%/7% and the efficiencies increase upto 5%.

(2) Under 400V/3/50Hz.

(3) Rated Condition without Pump Package.

(4) Electrical & system data are indicative and subject to change without notice. Please refer to unit nameplate data.

(5) If the power line of the unit is protected by fuses gG of the same size as the disconnect switch.

(6) For detail information refer submittal drawing which are available in the unit.



General Data

Table 2 – General data CGAF 080-190 High Efficiency

		CGAF 80 HE	CGAF 90 HE	CGAF 100 HE	CGAF 110 HE	CGAF 130 HE	CGAF 140 HE	CGAF 150 HE	CGAF 165 HE	CGAF 180 HE	CGAF 190 HE
Net Cooling Capacity For R410A (1)	(kW)	293.5	334.6	372.0	418.9	464.2	514.2	548.2	589.5	646.6	689.8
Net Total Power input For R410A (1)	(kW)	89.0	100.0	113.0	129.2	146.2	158.9	173.2	190.4	201.6	218.6
Unit electrical data (2) (3) (4)											
Short Circuit Unit Capacity	(kA)	15	15	15	15	15	15	15	15	15	15
Power Cable Cross Section (max)	mm ²	1*240	1*240	1*240	1*240	1*240	2*300	2*300	2*300	2*300	2*300
Disconnect switch size	(A)	315	400	400	500	500	630	630	630	800	800
Digit 56=1											
Maximum Power input	(kW)	121.2	142.6	161.8	176.0	190.2	220.9	240.1	254.3	270.8	285.0
Max. amps	(A)	201.4	234.2	262.7	290.5	318.3	360.2	388.7	416.5	448.7	476.4
Unit start up amps (w/o soft starter - digit 54=A) (4)	(A)	414.8	467.4	495.9	628.8	656.6	593.4	621.9	754.8	787.0	814.8
Unit start up amps (with soft starter - Digit 54=B) (4)	(A)	310.8	349.8	378.3	463.6	491.4	475.8	504.3	589.6	621.8	649.6
Displacement power factor	(dpf)	0.87	0.88	0.89	0.87	0.86	0.89	0.89	0.88	0.87	0.86
Digit 56=2											
Maximum Power input	(kW)	123.7	146.0	165.1	179.3	193.5	225.1	244.3	258.5	275.8	290.0
Max. amps	(A)	203.2	236.6	265.1	292.9	320.7	363.2	391.7	419.5	452.3	480.0
Unit start up amps (w/o soft starter - Digit 54=A) (4)	(A)	416.6	469.8	498.3	631.2	659.0	596.4	624.9	757.8	790.6	818.4
Unit start up amps (with soft starter - Digit 54=B) (4)	(A)	312.6	352.2	380.7	466.0	493.8	478.8	507.3	592.6	625.4	653.2
Power factor	(dpf)	0.88	0.89	0.90	0.88	0.87	0.89	0.90	0.89	0.88	0.87
Digit 56=3											
Maximum Power input	(kW)	125.3	148.1	167.3	181.5	195.7	227.8	247.0	261.2	279.0	293.2
Max. amps	(A)	205.6	239.8	268.3	296.1	323.9	367.2	395.7	423.5	457.1	484.8
Unit start up amps (w/o soft starter - Digit 54=A) (4)	(A)	419.0	473.0	501.5	634.4	662.2	600.4	628.9	761.8	795.4	823.2
Unit start up amps (with soft starter - Digit 54=B) (4)	(A)	315.0	355.4	383.9	469.2	497.0	482.8	511.3	596.6	630.2	658.0
Power factor	(dpf)	0.88	0.89	0.90	0.88	0.87	0.90	0.90	0.89	0.88	0.87
Compressor											
Compressor Number per Circuit	#	2	2	2	2	2	3	3	3	3	3
Type		Scroll	Scroll	Scroll	Scroll	Scroll	Scroll	Scroll	Scroll	Scroll	Scroll
Model Circuit 1 / Circuit 2	kW	25+25/ 25+25	25+30/ 25+30	30+30/ 30+30	30+40/ 30+40	40+40/ 40+40	25+30+30/ 25+30+30	30+30+30/ 30+30+30	30+30+40/ 30+30+40	30+40+40/ 30+40+40	40+40+40/ 40+40+40
Max Comp Power input Circuit 1 / Circuit 2	kW	28.4+28.4/ 28.4+28.4	34.1+44.3/ 34.1+44.3	38.2+38.2/ 38.2+38.2	38.2+45.2/ 38.2+45.2	45.2+45.2/ 45.2+45.2	28.4+38.2 +38.2/28.4	38.2+38.2 +38.2/38.2	38.2+38.2 +45.2/38.2	38.2+45.2 +45.2/38.2	45.2+45.2 +45.2/45.2
Rated Amps Circuit 1 / Circuit 2	(A)	47+47/ 47+47	47+61/ 47+61	61+61/ 61+61	61+75/ 61+75	75+75/ 75+75	47+61 +61/47 +61+61	61+61 +61/61 +61+61	61+61 +75/61 +61+75	61+75 +75/61 +75+75	75+75 +75/75 +75+75
Locked Rotor Amps Circuit 1 / Circuit 2 (direct start - Digit 54=A)	(A)	260+260/ 260+260	260+294/ 260+294	294+294/ 294+294	294+413/ 294+413	413+413/ 413+413	260+294 +294/260 +294+294	294+294 +294/294 +294+294	294+294 +413/294 +294+413	294+413 +413/294 +413+413	413+413 +413/413 +413+413
Locked Rotor Amps Circuit 1 / Circuit 2 (Soft starter - Digit 54=B)	(A)	156+156/ 156+156	156+176/ 156+176	176+176/ 176+176	176+248/ 176+248	248+248/ 248+248	156+176 +176/156 +176+176	176+176 +176/176 +176+176	176+176 +248/176 +176+248	176+248 +248/176 +248+248	248+248 +248/248 +248+248
Motor RPM	(rpm)	2900	2900	2900	2900	2900	2900	2900	2900	2900	2900
Oil sump heater Circuit 1 / Circuit 2	(W)	90+90/ 90+90	90+90/ 90+90	90+90/ 90+90	90+90/ 90+90	90+90/ 90+90	90+90 +90/90 +90+90	90+90 +90/90 +90+90	90+90 +90/90 +90+90	90+90 +90/90 +90+90	90+90 +90/90 +90+90
Evaporator											
Quantity	#	1	1	1	1	1	1	1	1	1	1
Type		Stainless steel Copper Brazed plate Heat exchanger									
Evaporator model		DFX650 x138	DFX650 x138	DFX650 x166	DFX650 x194	DFX650 x222	DFX650 x250	DFX650 x278	DFX650 x278	DFX650 x278	DFX650 x294
Evaporator Water Content volume	(l)	40.4	40.4	48.6	56.7	64.9	73.1	81.3	81.3	81.3	86
Nominal water connection size (Grooved coupling) - Without HYM	(in) -(mm)	4" - 114.3	4" - 114.3	4" - 114.3	4" - 114.3	4" - 114.3	5" - 139.7	5" - 139.7	5" - 139.7	5" - 139.7	5" - 139.7
Nominal water connection size (Grooved coupling) - With HYM	(in) -(mm)	4" - 114.3	4" - 114.3	4" - 114.3	4" - 114.3	4" - 114.3	5" - 139.7	5" - 139.7	5" - 139.7	5" - 139.7	5" - 139.7



General Data

Table 2 – General data CGAF 080-190 High Efficiency (continued)

		CGAF 80 HE	CGAF 90 HE	CGAF 100 HE	CGAF 110 HE	CGAF 130 HE	CGAF 140 HE	CGAF 150 HE	CGAF 165 HE	CGAF 180 HE	CGAF 190 HE
Hydraulic Module Components											
Single pump - Standard head pressure option											
Max available Head Pressure	(kPa)	155	136	119	103	92	146	134	122	161	149
Motor Power	(kW)	5.5	5.5	5.5	7.5	7.5	7.5	7.5	11.0	11.0	11.0
Rated Amps	(A)	11.0	11.0	11.0	14.4	14.4	14.4	14.4	20.8	20.8	20.8
Single pump - High head pressure option											
Max available Head Pressure	(kPa)	280	266	254	242	237	257	253	249	231	220
Motor Power	(kW)	11.0	11.0	11.0	11.0	11.0	15.0	15.0	15.0	15.0	15.0
Rated Amps	(A)	20.8	20.8	20.8	20.8	20.8	28.0	28.0	28.0	28.0	28.0
Twin pump - Standard head pressure option											
Max available Head Pressure	(kPa)	155	136	119	103	92	146	134	122	161	149
Motor Power	(kW)	5.5	5.5	5.5	7.5	7.5	7.5	7.5	11.0	11.0	11.0
Rated Amps	(A)	11.0	11.0	11.0	14.4	14.4	14.4	14.4	20.8	20.8	20.8
Twin pump - High head pressure option											
Max available Head Pressure	(kPa)	280	266	254	242	237	257	253	249	231	220
Motor Power	(kW)	11.0	11.0	11.0	11.0	11.0	15.0	15.0	15.0	15.0	15.0
Rated Amps	(A)	20.8	20.8	20.8	20.8	20.8	28.0	28.0	28.0	28.0	28.0
Expansion Tank Volume	(l)	50	50	50	50	50	50	50	50	50	50
Max User water loop Volume for factory mounted expansion tank (1)	(l)	1750	1750	1750	1750	1750	1750	1750	1750	1750	1750
Optional water Buffer tank volume	(l)	607	607	607	607	607	777	777	777	777	777
Antifreeze Heater without pump package and without buffer tank	(W)	420	420	420	520	520	640	640	640	640	640
Antifreeze Heater with pump package and without buffer tank (Single Water Pump digit 24=2 or 4 / Dual Water Pump digit 24=1 or 3)	(W)	1060 / 1120	1060 / 1120	1060 / 1120	1160 / 1220	1160 / 1220	1340 / 1400	1340 / 1400	1340 / 1400	1340 / 1400	1340 / 1400
Antifreeze Heater with pump package and with buffer tank (Single Water Pump digit 24=2 or 4 / Dual Water Pump digit 24=1 or 3)	(W)	1940 / 2000	1940 / 2000	1940 / 2000	2040 / 2100	2040 / 2100	2790 / 2850	2790 / 2850	2790 / 2850	2790 / 2850	2790 / 2850
Condenser											
Type		Full aluminium Micro channel heat exchanger									
Quantity of coil	#	6	8	8	8	8	10	10	10	12	12
Face area per circuit	(m ²)	8.88	11.84	11.84	11.84	11.84	14.8	14.8	14.8	17.76	17.76
Condenser Fan											
Quantity	#	6	8	8	8	8	10	10	10	12	12
Diameter	(mm)	800									
Fan / motor Type		Propeller fan : Fixed speed AC motor / Variable speed EC motor									
Digit 56=1											
Fan / motor Type		Fixed speed AC motor									
Airflow per fan	m ³ /h	15871	15965	15902	15823	15745	15835	15786	15728	15801	15751
Max Power Input per Motor	Kw	1.13	1.13	1.13	1.13	1.13	1.13	1.13	1.13	1.13	1.13
Max Amps per Motor	A	2.2	2.2	2.2	2.2	2.2	2.2	2.2	2.2	2.2	2.2
Motor RPM	(rpm)	910	910	910	910	910	910	910	910	910	910
Digit 56=2											
Fan / motor Type		Variable speed EC motor									
Airflow per fan	Kw	17339	17432	17370	17961	18777	17527	18372	19207	18163	18783
Max Power Input per Motor	Kw	1.55	1.55	1.55	1.55	1.55	1.55	1.55	1.55	1.55	1.55
Max Amps per Motor	A	2.5	2.5	2.5	2.5	2.5	2.5	2.5	2.5	2.5	2.5
Motor RPM (SN - Digit 15=X or LN - Digit 15=L)	(rpm)	840	840	840	870	910	850	890	930	880	910
Motor RPM (XLN - Digit 15=E)	(rpm)	830	830	830	830	830	830	830	830	830	830
Dimensions											
Unit Length	(mm)	3395	4520	4520	4520	4520	5645	5645	5645	6770	6770
Unit Width	(mm)	2200	2200	2200	2200	2200	2200	2200	2200	2200	2200
Std Unit Height	(mm)	2526	2526	2526	2526	2526	2526	2526	2526	2526	2526
Pump Package Option - (Additional length configuration)	(mm)	562	562	562	562	562	562	562	562	562	562

General Data

Table 2 – General data CGAF 080-190 High Efficiency (continued)

		CGAF 80 HE	CGAF 90 HE	CGAF 100 HE	CGAF 110 HE	CGAF 130 HE	CGAF 140 HE	CGAF 150 HE	CGAF 165 HE	CGAF 180 HE	CGAF 190 HE
Weights											
Shipping Weight (3)	(kg)	2015	2410	2540	2615	2675	3200	3375	3415	3785	3850
Option Additional shipping weight											
Single pump - Standard head pressure	(kg)	215	230	225	235	235	245	240	305	330	325
Single pump - High head pressure	(kg)	265	275	270	270	270	320	315	315	340	340
Twin pump - Standard head pressure	(kg)	305	315	315	335	335	345	340	450	475	470
Twin pump - High head pressure	(kg)	385	400	395	395	395	480	475	475	500	495
Pump VFD option	(kg)	70	70	70	70	70	70	70	70	70	70
Partial heat recovery option (Digit 19 = N)	(kg)	45	45	45	65	65	75	75	75	75	75
Partial heat recovery option (Digit 19 = P)	(kg)	45	45	45	45	45	75	75	75	75	75
Water Buffer tank option	(kg)	250	250	250	250	250	330	330	330	330	330
System data											
Nb of refrigerant circuit	#	2	2	2	2	2	2	2	2	2	2
Minimum cooling load % (6)	%	25	23	25	21	25	15	17	15	14	17
Total number of capacity steps	#	4	8	4	8	4	14	6	14	14	6
Standard/Partial Heat Recovery Unit											
R410A refrigerant charge Circuit 1 / Circuit 2	(kg)	22.0 / 22	27.5 / 27.5	27.5 / 27.5	28.5 / 28.5	29 / 29	39 / 39	39 / 39	39 / 39	43 / 43	43.5 / 43.5
R454B refrigerant charge Circuit 1 / Circuit 2	(kg)	18.5 / 18.5	23 / 23	23 / 23	23.5 / 23.5	24 / 24	32.5 / 32.5	32.5 / 32.5	32.5 / 32.5	35.5 / 35.5	36 / 36
Oil charge Circuit 1 / Circuit 2 (Digit 19 = N/C)	(l)	14.2 / 14.2	14.3 / 14.3	14.4 / 14.4	14.4 / 14.4	14.4 / 14.4	22.4 / 22.4	22.6 / 22.6	22.5 / 22.5	22.4 / 22.4	22.4 / 22.4
Oil charge Circuit 1 / Circuit 2 (Digit 19 = P)	(l)	16.2 / 16.2	16.3 / 16.3	16.4 / 16.4	16.4 / 16.4	16.4 / 16.4	24.4 / 24.4	24.6 / 24.6	24.5 / 24.5	24.4 / 24.4	24.4 / 24.4
POE Oil type						OIL058E / OIL057E					

(1) Indicative performance at Evaporator water temperature: 12°C / 7°C - Condenser air temperature 35°C - for detailed performances, on a given unit, consult Order Write Up.

With R454B refrigerant the Capacity/Power input may be reduced by 3% / 7% and the efficiencies increase upto 5%.

(2) Under 400V/3/50Hz.

(3) Rated Condition without Pump Package.

(4) Electrical & system data are indicative and subject to change without notice. Please refer to unit nameplate data.

(5) If the power line of the unit is protected by fuses gG of the same size as the disconnect switch.

(6) For detail information refer submittal drawing which are available in the unit.



General Data

Table 3 – General data CGAF 080-190 Extra Efficiency

		CGAF 80 XE	CGAF 90 XE	CGAF 100 XE	CGAF 110 XE	CGAF 130 XE	CGAF 140 XE	CGAF 150 XE	CGAF 165 XE	CGAF 180 XE	CGAF 190 XE
Net Cooling Capacity For R410A (1)	(kW)	297.5	337.4	376.4	426.6	477.2	522.5	561.5	608.0	660.3	708.8
Net Total Power input For R410A (1)	(kW)	87.1	98.5	110.8	126.4	143.0	155.3	169.4	186.0	197.4	213.9
Unit electrical data (2) (3) (4)											
Short Circuit Unit Capacity	(kA)	15	15	15	15	15	15	15	15	15	15
Power Cable Cross Section (max)	mm ²	1*240	1*240	1*240	1*240	1*240	2*300	2*300	2*300	2*300	2*300
Disconnect switch size	(A)	315	400	400	500	500	630	630	630	800	800
Maximum Power input	(kW)	125.30	148.12	167.29	181.49	195.70	227.82	246.99	261.19	279.04	293.24
Unit rated amps	(A)	205.58	239.84	268.3	296.08	323.86	367.24	395.7	423.48	457.06	484.84
Unit start up amps (w/o soft starter - Digit 54=A) (4)	(A)	419.01	473.04	501.5	634.39	662.17	600.44	628.9	761.79	795.37	823.15
Unit start up amps (with soft starter - Digit 54=B) (4)	(A)	315.01	355.44	383.9	469.19	496.97	482.84	511.3	596.59	630.17	657.95
Displacement power factor (dpf)	(dpf)	88%	89%	90%	88%	87%	90%	90%	89%	88%	87%
Compressor											
Compressor Number per Circuit	#	2	2	2	2	2	3	3	3	3	3
Type		Scroll	Scroll	Scroll	Scroll	Scroll	Scroll	Scroll	Scroll	Scroll	Scroll
Model Circuit 1 / Circuit 2	kW	25+25/ 25+25	25+30/ 25+30	30+30/ 30+30	30+40/ 30+40	40+40/ 40+40	25+30 +30/25 +30+30	30+30 +30/30 +30+30	30+30 +40/30 +30+40	30+40 +40/30 +40+40	40+40 +40/40 +40+40
Max Comp Power input Circuit 1 / Circuit 2	kW	28.4+28.4/ 28.4+28.4	28.4+38.2/ 28.4+38.2	38.2+38.2/ 38.2+38.2	38.2+45.2/ 38.2+45.2	45.2+45.2/ 45.2+45.2	28.4+38.2 +38.2/28.4 +38.2+38.2	38.2+38.2 +38.2/38.2 +38.2+38.2	38.2+38.2 +45.2/38.2 +38.2+45.2	38.2+45.2 +45.2/38.2 +45.2+45.2	45.2+45.2 +45.2/45.2 +45.2+45.2
Rated Amps Circuit 1 / Circuit 2	(A)	47+47/ 47+47	47+61/ 47+61	61+61/ 61+61	61+75/ 61+75	75+75/ 75+75	47+61 +61/47 +61+61	61+61 +61/61 +61+61	61+61 +75/61 +61+75	61+75 +75/61 +75+75	75+75 +75/75 +75+75
Locked Rotor Amps Circuit 1 / Circuit 2 (direct start - Digit 54=A)	(A)	260+260/ 260+260	260+294/ 260+294	294+294/ 294+294	294+413/ 294+413	413+413/ 413+413	260+294 +294/260 +294+294	294+294 +294/294 +294+294	294+294 +413/294 +294+413	294+413 +413/294 +413+413	413+413 +413/413 +413+413
Locked Rotor Amps Circuit 1 / Circuit 2 (Soft starter - Digit 54=B)	(A)	156+156/ 156+156	156+176/ 156+176	176+176/ 176+176	176+248/ 176+248	248+248/ 248+248	156+176 +176/156 +176+176	176+176 +176/176 +176+176	176+176 +248/176 +176+248	176+248. +248/176 +248+248	248+248 +248/248 +248+248
Motor RPM	(rpm)	2900	2900	2900	2900	2900	2900	2900	2900	2900	2900
Oil sump heater Circuit 1 / Circuit 2	(W)	90+90/ 90+90	90+90/ 90+90	90+90/ 90+90	90+90/ 90+90	90+90/ 90+90	90+90 +90/90 +90+90	90+90 +90/90 +90+90	90+90 +90/90 +90+90	90+90 +90/90 +90+90	90+90 +90/90 +90+90
Evaporator											
Quantity	#	1	1	1	1	1	1	1	1	1	1
Type		Stainless steel Copper Brazed plate Heat exchanger									
Evaporator model		DFX650 x138	DFX650 x138	DFX650 x166	DFX650 x194	DFX650 x222	DFX650 x250	DFX650 x278	DFX650 x278	DFX650 x278	DFX650 x294
Evaporator Water Content volume	(l)	40.4	40.4	48.6	56.7	64.9	73.1	81.3	81.3	81.3	86
Nominal water connection size (Grooved coupling) - Without HYM	(in) - (mm)	4" -114.3	4" -114.3	4" -114.3	4" -114.3	4" -114.3	5" -139.7	5" -139.7	5" -139.7	5" -139.7	5" -139.7
Nominal water connection size (Grooved coupling) - With HYM	(in) - (mm)	4" - 114.3	4" - 114.3	4" - 114.3	4" - 114.3	4" - 114.3	5" -139.7	5" -139.7	5" -139.7	5" -139.7	5" -139.7
Hydraulic Module Components											
Single pump - Standard head pressure option											
Max available Head Pressure	(kPa)	155	136	119	102	87	141	137	115	159	146
Motor Power	(kW)	5.5	5.5	5.5	7.5	7.5	7.5	7.5	11	11	11
Rated Amps	(A)	11	11	11	14.4	14.4	14.4	14.4	20.8	20.8	20.8
Single pump - High head pressure option											
Max available Head Pressure	(kPa)	280	266	254	241	232	252	257	245	229	218
Motor Power	(kW)	11	11	11	11	11	15	15	15	15	15
Rated Amps	(A)	20.8	20.8	20.8	20.8	20.8	28	28	28	28	28

General Data

Table 3 – General data CGAF 080-190 Extra Efficiency (continued)

		CGAF 80 XE	CGAF 90 XE	CGAF 100 XE	CGAF 110 XE	CGAF 130 XE	CGAF 140 XE	CGAF 150 XE	CGAF 165 XE	CGAF 180 XE	CGAF 190 XE
Twin pump - Standard head pressure option											
Max available Head Pressure	(kPa)	155	136	119	102	87	141	137	115	159	146
Motor Power	(kW)	5.5	5.5	5.5	7.5	7.5	7.5	7.5	11	11	11
Rated Amps	(A)	11	11	11	14.4	14.4	14.4	14.4	20.8	20.8	20.8
Twin pump - High head pressure option											
Max available Head Pressure	(kPa)	280	266	254	241	232	252	257	245	229	218
Motor Power	(kW)	11	11	11	11	11	15	15	15	15	15
Rated Amps	(A)	20.8	20.8	20.8	20.8	20.8	28	28	28	28	28
Expansion Tank Volume	(l)	50	50	50	50	50	50	50	50	50	50
Max User water loop Volume for factory mounted expansion tank (1)	(l)	1750	1750	1750	1750	1750	1750	1750	1750	1750	1750
Optional water Buffer tank volume	(l)	607	607	607	607	607	777	777	777	777	777
Antifreeze Heater without pump package and without buffer tank	(W)	420	420	420	520	520	640	640	640	640	640
Antifreeze Heater with pump package and without buffer tank (Single Water Pump digit 24=2 or 4 / Dual Water Pump digit 24=1 or 3)	(W)	1060 / 1120	1060 / 1120	1060 / 1120	1160 / 1220	1160 / 1220	1340 / 1400	1340 / 1400	1340 / 1400	1340 / 1400	1340 / 1400
Antifreeze Heater with pump package and with buffer tank (Single Water Pump digit 24=2 or 4 / Dual Water Pump digit 24=1 or 3)	(W)	1940/ 2000	1940/ 2000	1940/ 2000	1940/ 2000	2040/ 2100	2040/ 2100	2790/ 2850	2790/ 2850	2790/ 2850	2790/ 2850
Condenser											
Type		Full aluminium Micro channel heat exchanger									
Quantity of coil	#	6	8	8	8	8	10	10	10	12	12
Face area per circuit	(m ²)	8.88	11.84	11.84	11.84	11.84	14.80	14.80	14.80	17.76	17.76
Condenser Fan											
Quantity	#	6	8	8	8	8	10	10	10	12	12
Diameter	(mm)	800	800	800	800	800	800	800	800	800	800
Fan / motor Type		Variable speed EC strong motor									
Airflow per fan	m ³ /h	18936	19030	18967	19630	21037	19148	20584	21515	20103	21043
Max Power Input per Motor	Kw	1.95	1.95	1.95	1.95	1.95	1.95	1.95	1.95	1.95	1.95
Max Amps per Motor	A	3	3	3	3	3	3	3	3	3	3
Motor RPM (SN - Digit 15=X or LN - Digit 15=L)	(rpm)	830	830	830	860	920	840	900	940	880	920
Motor RPM (XLN - Digit 15=E)	(rpm)	780	780	780	780	780	780	780	780	780	780
Dimensions											
Unit Length	(mm)	3395	4520	4520	4520	4520	5645	5645	5645	6770	6770
Unit Width	(mm)	2200	2200	2200	2200	2200	2200	2200	2200	2200	2200
Std Unit Height	(mm)	2526	2526	2526	2526	2526	2526	2526	2526	2526	2526
Pump Package Option - (Additional length configuration)	(mm)	562	562	562	562	562	562	562	562	562	562
Weights (6)											
Shipping Weight (3)	(kg)	2015	2410	2540	2615	2675	3200	3375	3415	3785	3850
Option Additional shipping weight											
Single pump - Standard head pressure	(kg)	215	230	225	235	235	245	240	305	330	325
Single pump - High head pressure	(kg)	265	275	270	270	270	320	315	315	340	340
Twin pump - Standard head pressure	(kg)	305	315	315	335	335	345	340	450	475	470
Twin pump - High head pressure	(kg)	385	400	395	395	395	480	475	475	500	495



General Data

Table 3 – General data CGAF 080-190 Extra Efficiency (continued)

		CGAF 80 XE	CGAF 90 XE	CGAF 100 XE	CGAF 110 XE	CGAF 130 XE	CGAF 140 XE	CGAF 150 XE	CGAF 165 XE	CGAF 180 XE	CGAF 190 XE
Pump VFD option	(kg)	70	70	70	70	70	70	70	70	70	70
Partial heat recovery option (Digit 19 = N)	(kg)	45	45	45	65	65	75	75	75	75	75
Partial heat recovery option (Digit 19 = P)	(kg)	45	45	45	45	45	75	75	75	75	75
Water Buffer tank option	(kg)	250	250	250	250	250	330	330	330	330	330
System data											
Nb of refrigerant circuit	#	2	2	2	2	2	2	2	2	2	2
Minimum cooling load % (6)	%	25	23	25	21	25	15	17	15	14	17
Total number of capacity steps	#	4	8	4	8	4	14	6	14	14	6
Standard/Partial Heat Recovery Unit											
R410A refrigerant charge Circuit 1 / Circuit 2	(kg)	22.0 / 22.0	27.4 / 27.4	27.6 / 27.6	28.4 / 28.4	29.4 / 29.4	39.0 / 39.0	39.0 / 39.0	39.0 / 39.0	43.0 / 43.0	43.5 / 43.5
R454B refrigerant charge Circuit 1 / Circuit 2	(kg)	18.5 / 18.5	23 / 23	23 / 23	23.5 / 23.5	24.5 / 24.5	32.5 / 32.5	32.5 / 32.5	32.5 / 32.5	35.5 / 35.5	36 / 36
Oil charge Circuit 1 / Circuit 2 (Digit 19 = N/C)	(l)	14.2 / 14.2	14.3 / 14.3	14.4 / 14.4	14.4 / 14.4	14.4 / 14.4	22.4 / 22.4	22.6 / 22.6	22.5 / 22.5	22.4 / 22.4	22.4 / 22.4
Oil charge Circuit 1 / Circuit 2 (Digit 19 = P)	(l)	16.2 / 16.2	16.3 / 16.3	16.4 / 16.4	16.4 / 16.4	16.4 / 16.4	24.4 / 24.4	24.6 / 24.6	24.5 / 24.5	24.4 / 24.4	24.4 / 24.4
POE Oil type		OIL058E / OIL057E									

- (1) Indicative performance at Evaporator water temperature: 12°C / 7°C - Condenser air temperature 35°C - for detailed performances, on a given unit, consult Order Write Up.
 With R454B refrigerant the Capacity/Power input may be reduced by 3% / 7% and the efficiencies increase upto 5%.
- (2) Under 400V/3/50Hz.
- (3) Rated Condition without Pump Package.
- (4) Electrical & system data are indicative and subject to change without notice. Please refer to unit nameplate data.
- (5) If the power line of the unit is protected by fuses gG of the same size as the disconnect switch.
- (6) For detail information refer submittal drawing which are available in the unit.



General Data

Table 4 – General data CGAF 090-150 Standard Efficiency – Shell & Tube (R410A)

		CGAF 90 SE	CGAF 100 SE	CGAF 110 SE	CGAF 130 SE	CGAF 140 SE	CGAF 150 SE
Net Cooling Capacity (1)	(kW)	322.4	352.4	390.9	425.0	494.5	522.5
Net Total Power input in cooling (1)	(kW)	101.8	116.1	133.6	153.1	163.8	179.0
Unit electrical data (1) (2) (3) (4)							
Short Circuit Unit Capacity	(kA)	15	15	15	15	15	15
Power Cable Cross Section (max)	mm ²	1*240	1*240	1*240	1*240	2*300	2*300
Disconnect switch size	(A)	400	400	500	500	630	630
Digit 56=1							
Maximum Power input	(kW)	142.0	161.1	175.3	189.5	220.8	240.0
Unit rated amps	(A)	233.4	261.9	289.7	317.5	360.6	389.1
Unit start up amps (w/o soft starter - digit 54=A) (4)	(A)	466.6	495.1	628.0	655.8	593.8	622.3
Unit start up amps (with soft starter - Digit 54=B) (4)	(A)	349.0	377.5	462.8	490.6	476.2	504.7
Displacement power factor (dpf)	(dpf)	0.88	0.89	0.87	0.86	0.88	0.89
Digit 56=2							
Maximum Power input	(kW)	142.9	162.0	176.2	190.4	222.0	241.2
Max. amps	(A)	231.6	260.1	287.9	315.7	358.2	386.7
Unit start up amps (w/o soft starter - Digit 54=A) (4)	(A)	464.8	493.3	626.2	654.0	591.4	619.9
Unit start up amps (with soft starter - Digit 54=B) (4)	(A)	347.2	375.7	461.0	488.8	473.8	502.3
Displacement power factor (dpf)	(dpf)	0.89	0.90	0.88	0.87	0.89	0.90
Digit 56=3							
Maximum Power input	(kW)	144.5	163.6	177.9	192.1	224.2	243.3
Max. amps	(A)	234.0	262.5	290.3	318.1	361.4	389.9
Unit start up amps (w/o soft starter - Digit 54=A) (4)	(A)	467.2	495.7	628.6	656.4	594.6	623.1
Unit start up amps (with soft starter - Digit 54=B) (4)	(A)	349.6	378.1	463.4	491.2	477.0	505.5
Displacement power factor (dpf)	(dpf)	0.89	0.90	0.88	0.87	0.90	0.90
Compressor							
Compressor Number per Circuit	#	2	2	2	2	3	3
Type		Scroll	Scroll	Scroll	Scroll	Scroll	Scroll
Model Circuit 1 / Circuit 2	kW	25+30/25+30	30+30/30+30	30+40/30+40	40+40/40+40	25+30+30/ 25+30+30	30+30+30/ 30+30+30
Max Comp Power input Circuit 1 / Circuit 2	kW	28.4+38.2	38.2+38.2/ 38.2+38.2	38.2+45.2/ 38.2+45.2	45.2+45.2/ 45.2+45.2	28.4+38.2+38.2/ 28.4+38.2+38.2	38.2+38.2+38.2/ 38.2+38.2+38.2
Rated Amps Circuit 1 / Circuit 2	(A)	47+61/ 47+61	61+61/ 61+61	61+75/ 61+75	75+75/ 75+75	47+61+61/ 47+61+61	61+61+61/ 61+61+61
Locked Rotor Amps Circuit 1 / Circuit 2 (direct start - Digit 54=A)	(A)	260+294/ 260+294	294+294/ 294+294	294+413/ 294+413	413+413/ 413+413	260+294+294/ 260+294+294	294+294+294/ 294+294+294
Locked Rotor Amps Circuit 1 / Circuit 2 (Soft starter - Digit 54=B)	(A)	156+176/ 156+176	176+176/ 176+176	176+248/ 176+248	248+248/ 248+248	156+176+176/ 156+176+176	176+176+176/ 176+176+176
Motor RPM	(rpm)	2900	2900	2900	2900	2900	2900
Oil sump heater Circuit 1 / Circuit 2	(W)	90+90/ 90+90	90+90/ 90+90	90+90/ 90+90	90+90/ 90+90	90+90+90/ 90+90+90	90+90+90/ 90+90+90
Evaporator							
Quantity	#	1	1	1	1	1	1
Type		Shell & Tube Heat exchanger					
Evaporator model		3511	3511	3511	3511	3519	3519
Evaporator Water Content volume	(l)	--	--	--	--	--	--
Unit Connections							
Without pump package and no strainer							
Inlet / Outlet		8" / 8"	8" / 8"	8" / 8"	8" / 8"	8" / 8"	8" / 8"
Without pump package but strainer							
Inlet / Outlet		4" / 8"	4" / 8"	4" / 8"	4" / 8"	5" / 8"	5" / 8"
With pump package but no balance valve							
Inlet / Outlet		4" / 8"	4" / 8"	4" / 8"	4" / 8"	5" / 8"	5" / 8"
With pump package and balance valve							
Inlet / Outlet		4" / 4"	4" / 4"	4" / 4"	4" / 4"	5" / 5"	5" / 5"
Hydraulic Module Components							
Single pump - Standard head pressure option							
Max available Head Pressure	(kPa)	124	109	147	130	122	107
Motor Power	(kW)	5.5	5.5	7.5	7.5	7.5	7.5
Rated Amps	(A)	11	11	14.4	14.4	14.4	14.4
Single pump - High head pressure option							
Max available Head Pressure	(kPa)	254	242	223	205	234	224
Motor Power	(kW)	11	11	11	11	15	15
Rated Amps	(A)	20.8	20.8	20.8	20.8	28	28



General Data

Table 4 – General data CGAF 090-150 Standard Efficiency – Shell & Tube (R410A) (continued)

		CGAF 90 SE	CGAF 100 SE	CGAF 110 SE	CGAF 130 SE	CGAF 140 SE	CGAF 150 SE
Twin pump - Standard head pressure option							
Max available Head Pressure	(kPa)	124	109	147	130	122	107
Motor Power	(kW)	5.5	5.5	7.5	7.5	7.5	7.5
Rated Amps	(A)	11	11	14.4	14.4	14.4	14.4
Twin pump - High head pressure option							
Max available Head Pressure	(kPa)	254	242	223	205	234	224
Motor Power	(kW)	11	11	11	11	15	15
Rated Amps	(A)	20.8	20.8	20.8	20.8	28	28
Expansion Tank Volume	(l)	50	50	50	50	50	50
Max User water loop Volume for factory mounted expansion tank (1)	(l)	1750	1750	1750	1750	1750	1750
Antifreeze Heater without pump package							
Without filter option (digit 51=X)	(W)	200	200	200	200	200	200
With filter option (digit 50=A)	(W)	320	320	320	320	440	440
Antifreeze Heater with single pump package							
With balance valve (Digit 37=A)	(W)	1160	1160	1160	1160	1340	1340
Without balance valve (Digit 37=X)	(W)	900	900	900	900	1020	1020
Antifreeze Heater with dual pump package							
With balance valve (Digit 37=A)	(W)	1220	1220	1220	1220	1140	1140
Without balance valve (Digit 37=X)	(W)	960	960	960	960	1080	1080
Condenser							
Type		Full aluminium Micro channel heat exchanger					
Quantity of coil	#	6	6	6	6	8	8
Face area per circuit	(m ²)	8.88	8.88	8.88	8.88	11.84	11.84
Condenser Fan							
Quantity	#	6	6	6	6	8	8
Diameter	(mm)	800					
Fan / motor Type		Propeller fan : Fixed speed AC motor / Variable speed EC small motor / Variable speed EC strong motor					
Digit 56=1							
Fan / motor Type		Fixed speed AC motor					
Airflow per fan	m ³ /h	17117	17043	16949	16229	17001	16947
Max Power Input per Motor	Kw	1.4	1.4	1.4	1.4	1.4	1.4
Max Amps per Motor	A	2.8	2.8	2.8	2.8	2.8	2.8
Motor RPM	(rpm)	900	900	900	900	900	900
Digit 56=2							
Fan / motor Type		Variable speed EC small motor					
Airflow per fan	m ³ /h	15825	15752	16307	17082	15926	16738
Max Power Input per Motor	Kw	1.55	1.55	1.55	1.55	1.55	1.55
Max Amps per Motor	A	2.5	2.5	2.5	2.5	2.5	2.5
Motor RPM (SN - LN)	(rpm)	840	840	870	910	850	890
Motor RPM (XLN)	(rpm)	830	830	830	830	830	830
Digit 56 = 3							
Fan / motor Type		Variable speed EC strong motor					
Airflow per fan	m ³ /h	17149	17075	17695	19034	17271	18647
Max Power Input per Motor	Kw	1.95	1.95	1.95	1.95	1.95	1.95
Max Amps per Motor	A	3	3	3	3	3	3
Motor RPM (SN - LN)	(rpm)	830	830	870	920	840	900
Motor RPM (XLN)	(rpm)	780	780	780	780	780	780
Dimensions							
Unit Length	(mm)	3395	3395	3395	3395	4520	4520
Unit Width	(mm)	2200	2200	2200	2200	2200	2200
Std Unit Height	(mm)	2526	2526	2526	2526	2526	2526
Pump Package Option - (Additional length configuration)	(mm)	562	562	562	562	562	562
Weights (6)							
Shipping Weight (6)	(kg)	2267	2366	2414	2447	3071	3219
System data							
Nb of refrigerant circuit	#	2	2	2	2	2	2
Minimum cooling load % (6)	%	23	25	21	25	15	17
Total number of capacity steps	#	8	4	8	4	14	6



General Data

Table 4 – General data CGAF 090-150 Standard Efficiency – Shell & Tube (R410A) (continued)

		CGAF 90 SE	CGAF 100 SE	CGAF 110 SE	CGAF 130 SE	CGAF 140 SE	CGAF 150 SE
Standard/Partial Heat Recovery Unit							
R410A refrigerant charge Circuit 1 / Circuit 2	(kg)	20 / 20	20 / 20	20 / 20	20 / 20	30 / 30	30 / 30
Oil charge Circuit 1 / Circuit 2 (Digit 19 = N/C)	(l)	14.5 / 14.5	14.6 / 14.6	14.5 / 14.5	14.4 / 14.4	22.3 / 22.3	22.4 / 22.4
Oil charge Circuit 1 / Circuit 2 (Digit 19 = P)	(l)	15.5 / 15.5	15.6 / 15.6	15.5 / 15.5	15.4 / 15.4	23.3 / 23.3	23.4 / 23.4
POE Oil type		OIL058E / OIL057E					

(1) Indicative performance at Evaporator water temperature: 12°C / 7°C - Condenser air temperature 35°C - for detailed performances, on a given unit, consult Order Write Up.

(2) Under 400V/3/50Hz.

(3) Rated Condition without Pump Package.

(4) Electrical & system data are indicative and subject to change without notice. Please refer to unit nameplate data.

(5) If the power line of the unit is protected by fuses gG of the same size as the disconnect switch.

(6) For detail information refer submittal drawing which are available in the unit.



General Data

Table 5 – General data CXAF 080-110 Standard Efficiency

		CXAF 80 SSE	CXAF 90 SSE	CXAF 100 SSE	CXAF 80 SE	CXAF 90 SE	CXAF 100 SE	CXAF 110 SE
Net Cooling / Heating Capacity (1)	(kW)	265/283	291/316	319/346	281/286	310/317	341/352	383/392
Net Total Power input in cooling/heating (1)	(kW)	91/88	106/100	122/110	88/88	102/99	116/109	134/122
Unit electrical data (2) (3) (4)								
Short Circuit Unit Capacity	(kA)	15	15	15	15	15	15	15
Power Cable Cross Section (max)	mm ²	1*240	1*240	1*240	1*240	1*240	1*240	1*240
Disconnect switch size	(A)	315	400	400	315	400	400	500
Digit 56=1								
Maximum Power input	(kW)	122.8	142.0	161.1	123.4	142.6	161.8	178.1
Max. amps	(A)	205.0	233.4	261.9	205.8	234.2	262.7	295.3
Unit start up amps (w/o soft starter - Digit 54=A) (4)	(A)	418.4	466.6	495.1	419.2	467.4	495.9	633.6
Unit start up amps (with soft starter - Digit 54=B) (4)	(A)	314.4	349.0	377.5	315.2	349.8	378.3	468.4
Displacement power factor (dpf)	(dpf)	0.86	0.88	0.89	0.87	0.88	0.89	0.87
Digit 56=2								
Maximum Power input	(kW)	123.7	142.9	162.0	126.8	146.0	165.1	179.3
Unit rated amps	(A)	203.2	231.6	260.1	208.2	236.6	265.1	292.9
Unit start up amps (w/o soft starter - Digit 54=A) (4)	(A)	416.6	464.8	493.3	421.6	469.8	498.3	631.2
Unit start up amps (with soft starter - Digit 54=B) (4)	(A)	312.6	347.2	375.7	317.6	352.2	380.7	466.0
Displacement power factor (dpf)	(dpf)	0.88	0.89	0.90	0.88	0.89	0.90	0.88
Digit 56=3								
Maximum Power input	(kW)	125.3	144.5	163.6	128.9	148.1	167.3	181.5
Unit rated amps	(A)	205.6	234.0	262.5	211.4	239.8	268.3	296.1
Unit start up amps (w/o soft starter - Digit 54=A) (4)	(A)	419.0	467.2	495.7	424.8	473.0	501.5	634.4
Unit start up amps (with soft starter - Digit 54=B) (4)	(A)	315.0	349.6	378.1	320.8	355.4	383.9	469.2
Displacement power factor (dpf)	(dpf)	0.88	0.89	0.90	0.88	0.89	0.90	0.88
Compressor								
Compressor Number per Circuit	#	2	2	2	2	2	2	2
Type		Scroll	Scroll	Scroll	Scroll	Scroll	Scroll	Scroll
Model Circuit 1 / Circuit 2	kW	25+25/ 25+25	25+30/ 25+30	30+30/ 30+30	25+25/ 25+25	25+30/ 25+30	30+30/ 30+30	30+40/ 30+40
Max Comp Power input Circuit 1 / Circuit 2	kW	28.4+28.4/ 28.4+28.4	28.4+38.2/ 28.4+38.2	38.2+38.2/ 38.2+38.2	28.4+28.4/ 28.4+28.4	28.4+38.2/ 28.4+38.2	38.2+38.2/ 38.2+38.2	38.2+45.2/ 38.2+45.2
Rated Amps Circuit 1 / Circuit 2	(A)	90+90/ 90+90	90+90/ 90+90	90+90/ 90+90	90+90/ 90+90	90+90/ 90+90	90+90/ 90+90	90+90/ 90+90
Locked Rotor Amps Circuit 1 / Circuit 2 (direct start - Digit 54=A)	(A)	260+260/ 260+260	260+294/ 260+294	294+294/ 294+294	260+260/ 260+260	260+294/ 260+294	294+294/ 294+294	294+413/ 294+413
Locked Rotor Amps Circuit 1 / Circuit 2 (Soft starter - Digit 54=B)	(A)	156+156/ 156+156	156+176/ 156+176	176+176/ 176+176	156+156/ 156+156	156+176/ 156+176	176+176/ 176+176	176+248/ 176+248
Motor RPM	(rpm)	2900	2900	2900	2900	2900	2900	2900
Oil sump heater Circuit 1 / Circuit 2	(W)	112/112	112/112	112/112	112/112	112/112	112/112	112/112
Evaporator								
Quantity	#	1	1	1	1	1	1	1
Type		Stainless steel Copper Brazed plate Heat exchanger						
Evaporator model		C262X138	C262X138	C262X166	DFX650X138	DFX650X138	DFX650X166	DFX650X194
Evaporator Water Content volume	(l)	37	37	39	40.4	40.4	48.6	56.7
Nominal water connection size (Grooved coupling) - Without HYM	(in) - (mm)	4" - 114.3	4" - 114.3	4" - 114.3	4" - 114.3	4" - 114.3	4" - 114.3	4" - 114.3
Nominal water connection size (Grooved coupling) - With HYM	(in) - (mm)	4" - 114.3	4" - 114.3	4" - 114.3	4" - 114.3	4" - 114.3	4" - 114.3	4" - 114.3
Hydraulic Module Components								
Single pump - Standard head pressure option								
Max available Head Pressure	(kPa)	153	141	137	153	141	137	166
Motor Power	(kW)	5.5	5.5	5.5	5.5	5.5	5.5	7.5
Rated Amps	(A)	11	11	11	11	11	11	14.4
Single pump - High head pressure option								
Max available Head Pressure	(kPa)	266	254	252	266	254	252	242
Motor Power	(kW)	11	11	11	11	11	11	11
Rated Amps	(A)	20.8	20.8	20.8	20.8	20.8	20.8	20.8

General Data

Table 5 – General data CXAF 080-110 Standard Efficiency (continued)

		CXAF 80 SSE	CXAF 90 SSE	CXAF 100 SSE	CXAF 80 SE	CXAF 90 SE	CXAF 100 SE	CXAF 110 SE
Twin pump - Standard head pressure option								
Max available Head Pressure	(kPa)	153	141	137	153	141	137	166
Motor Power	(kW)	5.5	5.5	5.5	5.5	5.5	5.5	7.5
Rated Amps	(A)	11	11	11	11	11	11	14.4
Twin pump - High head pressure option								
Max available Head Pressure	(kPa)	266	254	252	266	254	252	242
Motor Power	(kW)	11	11	11	11	11	11	11
Rated Amps	(A)	20.8	20.8	20.8	20.8	20.8	20.8	20.8
Expansion Tank Volume	(l)	E50	50	50	E50	50	50	50
Max User water loop Volume for factory mounted expansion tank (1)	(l)	1750	1750	1750	1750	1750	1750	1750
Optional water Buffer tank volume	(l)	607	607	607	607	607	607	607
Antifreeze Heater without pump package and without buffer tank	(W)	420	420	420	420	420	420	520
Antifreeze Heater with pump package and without buffer tank (Single Water Pump digit 24=2 or 4 / Dual Water Pump digit 24=1 or 3)	(W)	1060 / 1120	1060 /	1060 /	1060 / 1120	1060 /	1060 /	1060 / 1220
Antifreeze Heater with pump package and with buffer tank (Single Water Pump digit 24=2 or 4 / Dual Water Pump digit 24=1 or 3)	(W)	1940 / 2000	1940 / 2000	1940 / 2000	1940 / 2000	1940 / 2000	1940 / 2000	2040 / 2100
Condenser								
Type		Fin-tube heat exchanger						
Quantity of coil	#	6	6	6	8	8	8	8
Face area per circuit	(m ²)	6.97	6.97	6.97	9.3	9.3	9.3	9.29
Condenser Fan								
Quantity	#	6	6	6	8	8	8	8
Diameter	(mm)	800						
Digit 56=1								
Fan / motor Type		Fixed speed AC motor						
Airflow per fan	m ³ /h	18082	18025	17963	16796	16751	16701	18035
Max Power Input per Motor	Kw	1.4	1.4	1.4	1.13	1.13	1.13	1.4
Max Amps per Motor	A	2.8	2.8	2.8	2.2	2.2	2.2	2.8
Motor RPM	(rpm)	900	900	900	910	910	910	900
Digit 56=2								
Fan / motor Type		Variable speed EC small motor						
Airflow per fan	m ³ /h	17385	18393	18969	15366	15745	16760	17977
Max Power Input per Motor	Kw	1.55	1.55	1.55	1.55	1.55	1.55	1.55
Max Amps per Motor	A	2.5	2.5	2.5	2.5	2.5	2.5	2.5
Motor RPM	(rpm)	870	920	950	770	790	840	900
Digit 56=3								
Fan / motor Type		Variable speed EC strong motor						
Airflow per fan	m ³ /h	17670	18782	19187	15445	15866	16983	18090
Max Power Input per Motor	Kw	1.82	1.82	1.82	1.82	1.82	1.82	1.82
Max Amps per Motor	A	2.9	2.9	2.9	2.9	2.9	2.9	2.9
Motor RPM	(rpm)	810	860	880	710	730	780	830
Dimensions								
Unit Length	(mm)	3395	3395	3395	4520	4520	4520	4520
Unit Width	(mm)	2200	2200	2200	2200	2200	2200	2200
Std Unit Height	(mm)	2526	2526	2526	2526	2526	2526	2526
Pump Package Option - (Additional length configuration)	(mm)	562	562	562	562	562	562	562
Weights (6)								
Shipping Weight (6)	(kg)	2379	2481	2598	2765	2864	2999	3081
Option Additional shipping weight (6)								
Single pump - Standard head pressure	(kg)	257	257	257	254	254	254	264
Single pump - High head pressure	(kg)	304	304	304	301	301	301	301
Twin pump - Standard head pressure	(kg)	346	346	346	343	343	343	363
Twin pump - High head pressure	(kg)	428	428	428	425	425	425	425
XLN option	(kg)	114	114	114	114	114	114	114
Pump VFD option	(kg)	70	70	70	70	70	70	70
Water Buffer tank option	(kg)	286	286	286	286	286	286	286



General Data

Table 5 – General data CXAF 080-110 Standard Efficiency (continued)

		CXAF 80 SSE	CXAF 90 SSE	CXAF 100 SSE	CXAF 80 SE	CXAF 90 SE	CXAF 100 SE	CXAF 110 SE
System data								
Nb of refrigerant circuit	#	2	2	2	2	2	2	2
Minimum cooling load % (6)	%	25	23	25	25	23	25	22
Total number of capacity steps	#	4	8	4	4	8	4	8
Standard/Partial Heat Recovery Unit								
R410A refrigerant charge Circuit 1 / Circuit 2	(kg)	36/36	36/36	36/36	38/39	39/40	39/40	43 / 43
R454B refrigerant charge Circuit 1 / Circuit 2	(kg)	29/29	29/29	29/29	35/35	35/35	36/35	36/35
Oil charge Circuit 1 / Circuit 2	(l)	16.1 / 16.1	16.2 / 16.2	16.4 / 16.4	17.1 / 17.1	17.2 / 17.2	17.4 / 17.4	17.4 / 17.4
POE Oil type		OIL058E / OIL057E						

(1) Indicative performance at Evaporator water temperature : 12°C / 7°C - Condenser air temperature 35°C for cooling & Condenser water temperature: 40°C / 45°C - Evaporator air temperature 7°C (6°C) - for detailed performances, on a given unit, consult Order Write Up.

With R454B refrigerant the Capacity/Power input may be reduced by 3%/7% and the efficiencies increase upto 5%.

(2) Under 400V/3/50Hz.

(3) Rated Condition without Pump Package.

(4) Electrical & system data are indicative and subject to change without notice. Please refer to unit nameplate data.

(5) If the power line of the unit is protected by fuses gG of the same size as the disconnect switch.

(6) For detail information refer submittal drawing which are available in the unit.



General Data

Table 6 – General data CXAF 130-190 Standard Efficiency

		CXAF 130 SE	CXAF 140 SE	CXAF 150 SE	CXAF 165 SE	CXAF 180 SE	CXAF 190 SE
Net Cooling / Heating Capacity (1)	(kW)	420/430	469/482	497/514	530/548	592/612	628/647
Net Total Power input in cooling/heating (1)	(kW)	152/134	164/152	179/162	197/174	209/190	227/201
Unit electrical data (2) (3) (4)							
Short Circuit Unit Capacity	(kA)	15	15	15	15	15	15
Power Cable Cross Section (max)	mm ²	1*240	2*300	2*300	2*300	2*300	2*300
Disconnect switch size	(A)	500	630	630	630	800	800
Digit 56=1							
Maximum Power input	(kW)	192.3	223.6	242.8	257.0	274.0	288.2
Max. amps	(A)	323.1	366.2	394.7	422.5	455.9	483.6
Unit start up amps (w/o soft starter - Digit 54=A) (4)	(A)	661.4	599.4	627.9	760.8	794.2	822.0
Unit start up amps (with soft starter - Digit 54=B) (4)	(A)	496.2	481.8	510.3	595.6	629.0	656.8
Displacement power factor (dpf)	(dpf)	0.86	0.88	0.89	0.88	0.87	0.86
Digit 56=2							
Maximum Power input	(kW)	193.5	225.1	244.3	258.5	275.8	290.0
Unit rated amps	(A)	320.7	363.2	391.7	419.5	452.3	480.0
Unit start up amps (w/o soft starter - Digit 54=A) (4)	(A)	659.0	596.4	624.9	757.8	790.6	818.4
Unit start up amps (with soft starter - Digit 54=B) (4)	(A)	493.8	478.8	507.3	592.6	625.4	653.2
Displacement power factor (dpf)	(dpf)	0.87	0.89	0.90	0.89	0.88	0.87
Digit 56=3							
Maximum Power input	(kW)	195.7	227.8	247.0	261.2	279.0	293.2
Unit rated amps	(A)	323.9	367.2	395.7	423.5	457.1	484.8
Unit start up amps (w/o soft starter - Digit 54=A) (4)	(A)	662.2	600.4	628.9	761.8	795.4	823.2
Unit start up amps (with soft starter - Digit 54=B) (4)	(A)	497.0	482.8	511.3	596.6	630.2	658.0
Displacement power factor (dpf)	(dpf)	0.87	0.90	0.90	0.89	0.88	0.87
Compressor							
Compressor Number per Circuit	#	2	3	3	3	3	3
Type		Scroll	Scroll	Scroll	Scroll	Scroll	Scroll
Model Circuit 1 / Circuit 2	kW	40+40/ 40+40	25+30+30/ 25+30+30	30+30+30/ 30+30+30	30+30+40/ 30+30+40	30+40+40/ 30+40+40	40+40+40/ 40+40+40
Max Comp Power input Circuit 1 / Circuit 2	kW	45.2+45.2/ 45.2+45.2	28.4+38.2+38.2/ 28.4+38.2+38.2	38.2+38.2+38.2/ 38.2+38.2+38.2	38.2+38.2+45.2/ 38.2+38.2+45.2	38.2+45.2+45.2/ 38.2+45.2+45.2	45.2+45.2+45.2/ 45.2+45.2+45.2
Rated Amps Circuit 1 / Circuit 2	(A)	90+90/ 90+90	90+90+90/ 90+90+90	90+90+90/ 90+90+90	90+90+90/ 90+90+90	90+90+90/ 90+90+90	90+90+90/ 90+90+90
Locked Rotor Amps Circuit 1 / Circuit 2 (direct start - Digit 54=A)	(A)	413+413/ 413+413	260+294+294/ 260+294+294	294+294+294/ 294+294+294	294+294+413/ 294+294+413	294+413+413/ 294+413+413	413+413+413/ 413+413+413
Locked Rotor Amps Circuit 1 / Circuit 2 (Soft starter - Digit 54=B)	(A)	248+248/ 248+248	156+176 +176/156 +176+176	176+176 +176/176 +176+176	176+176 +248/176 +176+248	176+248 +248/176 +248+248	248+248 +248/248 +248+248
Motor RPM	(rpm)	2900	2900	2900	2900	2900	2900
Oil sump heater Circuit 1 / Circuit 2	(W)	112/112	168/168	168/168	168/168	168/168	168/168
Evaporator							
Quantity	#	1	1	1	1	1	1
Type		Stainless steel Copper Brazed plate Heat exchanger					
Evaporator model		DFX650X222	DFX650X250	DFX650X278	DFX650X278	DFX650X278	DFX650X294
Evaporator Water Content volume	(l)	64.9	73.1	81.3	81.3	81.3	86
Nominal water connection size (Grooved coupling) - Without HYM	(in) - (mm)	4" - 114.3	5" - 139.7	5" - 139.7	5" - 139.7	5" - 139.7	5" - 139.7
Nominal water connection size (Grooved coupling) - With HYM	(in) - (mm)	4" - 114.3	5" - 139.7	5" - 139.7	5" - 139.7	5" - 139.7	5" - 139.7
Hydraulic Module Components							
Single pump - Standard head pressure option							
Max available Head Pressure	(kPa)	157	141	143	182	163	154
Motor Power	(kW)	7.5	7.5	7.5	11	11	11
Rated Amps	(A)	14.4	14.4	14.4	20.8	20.8	20.8
Single pump - High head pressure option							
Max available Head Pressure	(kPa)	232	252	258	249	230	221
Motor Power	(kW)	11	15	15	15	15	15
Rated Amps	(A)	20.8	28	28	28	28	28



General Data

Table 6 – General data CXAF 130 -190 Standard Efficiency (continued)

		CXAF 130 SE	CXAF 140 SE	CXAF 150 SE	CXAF 165 SE	CXAF 180 SE	CXAF 190 SE
Twin pump - Standard head pressure option							
Max available Head Pressure	(kPa)	157	141	143	182	163	154
Motor Power	(kW)	7.5	7.5	7.5	11	11	11
Rated Amps	(A)	14.4	14.4	14.4	20.8	20.8	20.8
Twin pump - High head pressure option							
Max available Head Pressure	(kPa)	232	252	258	249	230	221
Motor Power	(kW)	11	15	15	15	15	15
Rated Amps	(A)	20.8	28	28	28	28	28
Expansion Tank Volume	(l)	50	50	50	50	50	50
Max User water loop Volume for factory mounted expansion tank (1)	(l)	1750	1750	1750	1750	1750	1750
Optional water Buffer tank volume	(l)	607	777	777	777	777	777
Antifreeze Heater without pump package and without buffer tank	(W)	520	640	640	640	640	640
Antifreeze Heater with pump package and without buffer tank (Single Water Pump digit 24=2 or 4 / Dual Water Pump digit 24=1 or 3)	(W)	1060 / 1220	1340 / 1400	1340 / 1400	1340 / 1400	1340 / 1400	1340 / 1400
Antifreeze Heater with pump package and with buffer tank (Single Water Pump digit 24=2 or 4 / Dual Water Pump digit 24=1 or 3)	(W)	2040 / 2100	2790 / 2850	2790 / 2850	2790 / 2850	2790 / 2850	2790 / 2850
Condenser							
Type		Fin-tube heat exchanger					
Quantity of coil	#	8	10	10	10	12	12
Face area per circuit	(m ²)	9.29	11.61	11.61	11.61	13.93	13.93
Condenser Fan							
Quantity	#	8	10	10	10	12	12
Diameter	(mm)	800	800	800	800	800	800
Digit 56=1							
Fan / motor Type	#	#	#	#	#	#	#
Airflow per fan	m ³ /h	17976	18047	18010	17966	18018	17980
Max Power Input per Motor	Kw	1.4	1.4	1.4	1.4	1.4	1.4
Max Amps per Motor	A	2.8	2.8	2.8	2.8	2.8	2.8
Motor RPM	(rpm)	900	900	900	900	900	900
Digit 56=2							
Fan / motor Type	#	#	#	#	#	#	#
Airflow per fan	m ³ /h	18983	17562	18378	18974	17959	18987
Max Power Input per Motor	Kw	1.55	1.55	1.55	1.55	1.55	1.55
Max Amps per Motor	A	2.5	2.5	2.5	2.5	2.5	2.5
Motor RPM	(rpm)	950	880	920	950	900	950
Digit 56 =3							
Fan / motor Type	#	#	#	#	#	#	#
Airflow per fan	m ³ /h	19201	17868	18533	19191	18307	19204
Max Power Input per Motor	Kw	1.82	1.82	1.82	1.82	1.82	1.82
Max Amps per Motor	A	2.9	2.9	2.9	2.9	2.9	2.9
Motor RPM	(rpm)	880	820	850	880	840	880
Dimensions							
Unit Length	(mm)	4520	5645	5645	5645	6770	6770
Unit Width	(mm)	2200	2200	2200	2200	2200	2200
Std Unit Height	(mm)	2526	2526	2526	2526	2526	2526
Pump Package Option - (Additional length configuration)	(mm)	562	562	562	562	562	562
Weights (6)							
Shipping Weight (6)	(kg)	3141	3768	3944	3984	4438	4507
Option Additional shipping weight (6)							
Single pump - Standard head pressure	(kg)	264	287	287	351	401	401
Single pump - High head pressure	(kg)	301	363	363	363	413	413
Twin pump - Standard head pressure	(kg)	363	386	386	495	545	545
Twin pump - High head pressure	(kg)	425	521	521	521	571	571
XLN option	(kg)	114	145	145	145	145	145
Pump VFD option	(kg)	70	70	70	70	70	70
Water Buffer tank option	(kg)	286	379	379	379	379	379

General Data

Table 6 – General data CXAF 130 -190 Standard Efficiency (continued)

		CXAF 130 SE	CXAF 140 SE	CXAF 150 SE	CXAF 165 SE	CXAF 180 SE	CXAF 190 SE
System data							
Nb of refrigerant circuit	#	2	2	2	2	2	2
Minimum cooling load % (6)	%	25	15	17	15	14	17
Total number of capacity steps	#	4	14	6	14	14	6
Option Additional shipping weight (6)					#		
R410A refrigerant charge Circuit 1 / Circuit 2	(kg)	43 / 43	59 / 58	60 / 59	60 / 59	69 / 68	69 / 68
R454B refrigerant charge Circuit 1 / Circuit 2	(kg)	36/35	47/46	47/46	47/46	54/53	54/54
Oil charge Circuit 1 / Circuit 2	(l)	17.4 / 17.4	25.4/25.4	25.6/25.6	25.5/25.5	26.3/26.3	26.3/26.3
POE Oil type				OIL058E / OIL057E			

(1) Indicative performance at Evaporator water temperature : 12°C / 7°C - Condenser air temperature 35°C for cooling & Condenser water temperature: 40°C / 45°C - Evaporator air temperature 7°C (6°C) - for detailed performances, on a given unit, consult Order Write Up. With R454B refrigerant the Capacity/Power input may be reduced by 3%/7% and the efficiencies increase upto 5%.

(2) Under 400V/3/50Hz.

(3) Rated Condition without Pump Package.

(4) Electrical & system data are indicative and subject to change without notice. Please refer to unit nameplate data.

(5) If the power line of the unit is protected by fuses gG of the same size as the disconnect switch.

(6) For detail information refer submittal drawing which are available in the unit.



General Data

Table 7 – General data CXAF 080-110 High Efficiency

		CXAF 80 SHE	CXAF 90 SHE	CXAF 100 SHE	CXAF 80 HE	CXAF 90 HE	CXAF 100 HE	CXAF 110 HE
Net Cooling / Heating Capacity (1)	(kW)	262/290	287/321	315/352	276/294	305/326	336/359	376/400
Net Total Power input in cooling/ heating (1)	(kW)	91/86	106/97	121/106	88/86	102/98	116/107	133/120
Unit electrical data (2) (3) (4)								
Short Circuit Unit Capacity	(kA)	15	15	15	15	15	15	15
Power Cable Cross Section (max)	mm ²	1*240	1*240	1*240	1*240	1*240	1*240	1*240
Disconnect switch size	(A)	315	400	400	315	400	400	500
Digit 56=1								
Maximum Power input	(kW)	122.8	142.0	161.1	123.4	142.6	161.8	178.1
Max. amps	(A)	205.0	233.4	261.9	205.8	234.2	262.7	295.3
Unit start up amps (w/o soft starter -Digit 54=A) (4)	(A)	418.4	466.6	495.1	419.2	467.4	495.9	633.6
Unit start up amps (with soft starter -Digit 54=B) (4)	(A)	314.4	349.0	377.5	315.2	349.8	378.3	468.4
Displacement power factor	(dpf)	0.86	0.88	0.89	0.87	0.88	0.89	0.87
Digit 56=2								
Maximum Power input	(kW)	123.7	142.9	162.0	126.8	146.0	165.1	179.3
Max. amps	(A)	203.2	231.6	260.1	208.2	236.6	265.1	292.9
Unit start up amps (w/o soft starter - Digit 54=A) (4)	(A)	416.6	464.8	493.3	421.6	469.8	498.3	631.2
Unit start up amps (with soft starter - Digit 54=B) (4)	(A)	312.6	347.2	375.7	317.6	352.2	380.7	466.0
Displacement power factor	(dpf)	0.88	0.89	0.90	0.88	0.89	0.90	0.88
Digit 56 =3								
Maximum Power input	(kW)	125.3	144.5	163.6	128.9	148.1	167.3	181.5
Max. amps	(A)	205.6	234.0	262.5	211.4	239.8	268.3	296.1
Unit start up amps (w/o soft starter - Digit 54=A) (4)	(A)	419.0	467.2	495.7	424.8	473.0	501.5	634.4
Unit start up amps (with soft starter - Digit 54=B) (4)	(A)	315.0	349.6	378.1	320.8	355.4	383.9	469.2
Displacement power factor	(dpf)	0.88	0.89	0.90	0.88	0.89	0.90	0.88
Compressor								
Compressor Number per Circuit	#	2	2	2	2	2	2	2
Type		Scroll	Scroll	Scroll	Scroll	Scroll	Scroll	Scroll
Model Circuit 1 / Circuit 2	kW	25+25/ 25+25	25+30/ 25+30	30+30/ 30+30	25+25/ 25+25	25+30/ 25+30	30+30/ 30+30	30+40/ 30+40
Max Comp Power input Circuit 1 / Circuit 2	kW	28.4+28.4/ 28.4+28.4	28.4+38.2/ 28.4+38.2	38.2+38.2/ 38.2+38.2	28.4+28.4/ 28.4+28.4	28.4+38.2/ 28.4+38.2	38.2+38.2/ 38.2+38.2	38.2+45.2/ 38.2+45.2
Rated Amps Circuit 1 / Circuit 2	(A)	47+47/ 47+47	47+61/ 47+61	61+61/ 61+61	47+47/ 47+47	47+61/ 47+61	61+61/ 61+61	61+75/ 61+75"
Locked Rotor Amps Circuit 1 / Circuit 2 (direct start - Digit 54=A)	(A)	260+260/ 260+260	260+294/ 260+294	294+294/ 294+294	260+260/ 260+260	260+294/ 260+294	294+294/ 294+294	294+413/ 294+413
Locked Rotor Amps Circuit 1 / Circuit 2 (Soft starter - Digit 54=B)	(A)	156+156/ 156+156	156+176/ 156+176	176+176/ 176+176	156+156/ 156+156	156+176/ 156+176	176+176/ 176+176	176+248/ 176+248
Motor RPM	(rpm)	2900	2900	2900	2900	2900	2900	2900
Oil sump heater Circuit 1 / Circuit 2	(W)	90+90/ 90+90	90+90/ 90+90	90+90/ 90+90	90+90/ 90+90	90+90/ 90+90	90+90/ 90+90	90+90/ 90+90
Evaporator								
Quantity	#	1	1	1	1	1	1	1
Type		Stainless steel Copper Brazed plate Heat exchanger						
Evaporator model		C262X138	C262X138	C262X166	DFX650X138	DFX650X138	DFX650X166	DFX650X194
Evaporator Water Content volume	(l)	37	37	39	40.4	40.4	48.6	56.7
Nominal water connection size (Grooved coupling) - Without HYM	(in) -(mm)	4" - 114.3	4" - 114.3	4" - 114.3	4" - 114.3	4" - 114.3	4" - 114.3	4" - 114.3
Nominal water connection size (Grooved coupling) - With HYM	(in) -(mm)	4" - 114.3	4" - 114.3	4" - 114.3	4" - 114.3	4" - 114.3	4" - 114.3	4" - 114.3
Maximum pressure on water side without pump package	(BarA)	10	10	10	10	10	10	10
Hydraulic Module Components								
Single pump - Standard head pressure option								
Max available Head Pressure	(kPa)	153	141	137	153	141	137	166
Motor Power	(kW)	5.5	5.5	5.5	5.5	5.5	5.5	7.5
Rated Amps	(A)	11.0	11.0	11.0	11.0	11.0	11.0	14.4

General Data

Table 7 – General data CXAF 080-110 High Efficiency (continued)

		CXAF 80 SHE	CXAF 90 SHE	CXAF 100 SHE	CXAF 80 HE	CXAF 90 HE	CXAF 100 HE	CXAF 110 HE
Single pump - High head pressure option								
Max available Head Pressure	(kPa)	266	254	252	266	254	252	242
Motor Power	(kW)	11.0	11.0	11.0	11.0	11.0	11.0	11.0
Rated Amps	(A)	20.8	20.8	20.8	20.8	20.8	20.8	20.8
Twin pump - Standard head pressure option								
Max available Head Pressure	(kPa)	153	141	137	153	141	137	166
Motor Power	(kW)	5.5	5.5	5.5	5.5	5.5	5.5	7.5
Rated Amps	(A)	11.0	11.0	11.0	11.0	11.0	11.0	14.4
Twin pump - High head pressure option								
Max available Head Pressure	(kPa)	266	254	252	266	254	252	242
Motor Power	(kW)	11	11	11	11	11	11	11
Rated Amps	(A)	20.8	20.8	20.8	20.8	20.8	20.8	20.8
Expansion Tank Volume	(l)	50	50	50	50	50	50	50
Max User water loop Volume for factory mounted expansion tank (1)	(l)	1750	1750	1750	1750	1750	1750	1750
Optional water Buffer tank volume	(l)	607	607	607	607	607	607	607
Antifreeze Heater without pump package and without buffer tank	(W)	420	420	420	420	420	420	520
Antifreeze Heater with pump package and without buffer tank (Single Water Pump digit 24=2 or 4 / Dual Water Pump digit 24=1 or 3)	(W)	1060/1120	1060/1120	1060/1120	1060/1120	1060/1120	1060/1120	1060/1120
Antifreeze Heater with pump package and with buffer tank (Single Water Pump digit 24=2 or 4 / Dual Water Pump digit 24=1 or 3)	(W)	1940/2000	1940/2000	1940/2000	1940/2000	1940/2000	1940/2000	2040/2100
Antifreeze Heater with pump package and with buffer tank (Single Water Pump digit 24=2 or 4 / Dual Water Pump digit 24=1 or 3)	(W)	1940/2000	1940/2000	1940/2000	2040/2100	2040/2100	2790/2850	2790/2850
Condenser								
Type		Fin-tube heat exchanger						
Quantity of coil	#	6	6	6	8	8	8	8
Face area per circuit	(m ²)	6.97	6.97	6.97	9.3	9.3	9.3	9.29
Condenser Fan								
Quantity	#	6	6	6	8	8	8	8
Diameter	(mm)	800						
Digit 56=1								
Fan / motor Type		Fixed speed AC motor						
Airflow per fan	m ³ /h	18087	18030	17969	16801	16756	16707	18042
Max Power Input per Motor	Kw	1.4	1.4	1.4	1.4	1.4	1.4	1.13
Max Amps per Motor	A	2.8	2.8	2.8	2.8	2.8	2.8	2.2
Motor RPM	(rpm)	900	900	900	910	910	910	900
Digit 56=2								
Fan / motor Type		Variable speed EC small motor						
Airflow per fan	m ³ /h	17390	18399	18976	15370	15751	16766	17984
Max Power Input per Motor	Kw	1.55	1.55	1.55	1.55	1.55	1.55	1.55
Max Amps per Motor	A	2.5	2.5	2.5	2.5	2.5	2.5	2.5
Motor RPM	(rpm)	870	920	950	770	790	840	900
Digit 56=3								
Fan / motor Type		Variable speed EC strong motor						
Airflow per fan	m ³ /h	17675	18788	19194	15450	15871	16989	18098
Max Power Input per Motor	Kw	1.82	1.82	1.82	1.82	1.82	1.82	1.82
Max Amps per Motor	A	2.9	2.9	2.9	2.9	2.9	2.9	2.9
Motor RPM	(rpm)	810	860	880	710	730	780	830
Dimensions								
Unit Length	(mm)	3395	3395	3395	4520	4520	4520	4520
Unit Width	(mm)	2200	2200	2200	2200	2200	2200	2200
Std Unit Height	(mm)	2526	2526	2526	2526	2526	2526	2526
Pump Package Option - (Additional length configuration)	(mm)	562	562	562	562	562	562	562



General Data

Table 7 – General data CXAF 080-110 High Efficiency (continued)

		CXAF 80 SHE	CXAF 90 SHE	CXAF 100 SHE	CXAF 80 HE	CXAF 90 HE	CXAF 100 HE	CXAF 110 HE
Weights								
Shipping Weight (3)	(kg)	2448	2549	2666	2815	2914	3059	3141
Option Additional shipping weight								
Single pump - Standard head pressure	(kg)	257	257	257	254	254	254	264
Single pump - High head pressure	(kg)	304	304	304	301	301	301	301
Twin pump - Standard head pressure	(kg)	346	346	346	343	343	343	363
Twin pump - High head pressure	(kg)	428	428	428	425	425	425	425
XLN option	(kg)	114	114	114	114	114	114	114
Pump VFD option	(kg)	70	70	70	70	70	70	70
Water Buffer tank option	(kg)	286	286	286	286	286	286	286
System data								
Nb of refrigerant circuit	#	2	2	2	2	2	2	2
Minimum cooling load % (6)	%	25	23	25	25	23	25	22
Total number of capacity steps	#	4	8	4	4	8	4	8
Standard/Partial Heat Recovery Unit								
R410A refrigerant charge Circuit 1 / Circuit 2	(kg)	41 / 41	41 / 41	42 / 42	45 / 46	46 / 47	46 / 47	50 / 50
R454B refrigerant charge Circuit 1 / Circuit 2	(kg)	35/35	35/35	35/35	42/42	42/42	43/42	43/42
Oil charge Circuit 1 / Circuit 2	(l)	16.1 / 16.1	16.2 / 16.2	16.4 / 16.4	17.1 / 17.1	17.2 / 17.2	17.4 / 17.4	17.4 / 17.4
POE Oil type		OIL058E / OIL057E						

(1) Indicative performance at Evaporator water temperature : 12°C / 7°C - Condenser air temperature 35°C for cooling & Condenser water temperature: 40°C / 45°C - Evaporator air temperature 7°C (6°C) - for detailed performances, on a given unit, consult Order Write Up.

With R454B refrigerant the Capacity/Power input may be reduced by 3%/7% and the efficiencies increase upto 5%.

(2) Under 400V/3/50Hz.

(3) Rated Condition without Pump Package.

(4) Electrical & system data are indicative and subject to change without notice. Please refer to unit nameplate data.

(5) If the power line of the unit is protected by fuses gG of the same size as the disconnect switch.

(6) For detail information refer submittal drawing which are available in the unit.

General Data

Table 8 – General data CXAF 130-190 High Efficiency

		CXAF 130 HE	CXAF 140 HE	CXAF 150 HE	CXAF 165 HE	CXAF 180 HE	CXAF 190 HE
Net Cooling / Heating Capacity (1)	(kW)	413/437	460/492	487/522	519/556	579/619	614/655
Net Total Power input in cooling/heating (1)	(kW)	151/131	163/148	178/158	196/170	208/186	225/197
Unit electrical data (2) (3) (4)							
Short Circuit Unit Capacity	(kA)	15	15	15	15	15	15
Power Cable Cross Section (max)	mm ²	1*240	2*300	2*300	2*300	2*300	2*300
Disconnect switch size	(A)	500	630	630	630	800	800
Digit 56=1							
Maximum Power input	(kW)	192.3	223.6	242.8	257.0	274.0	288.2
Max. amps	(A)	323.1	366.2	394.7	422.5	455.9	483.6
Unit start up amps (w/o soft starter -digit 54=A) (4)	(A)	661.4	599.4	627.9	760.8	794.2	822.0
Unit start up amps (with soft starter -Digit 54=B) (4)	(A)	496.2	481.8	510.3	595.6	629.0	656.8
Displacement power factor	(dpf)	0.86	0.88	0.89	0.88	0.87	0.86
Digit 56=2							
Maximum Power input	(kW)	193.5	225.1	244.3	258.5	275.8	290.0
Max. amps	(A)	320.7	363.2	391.7	419.5	452.3	480.0
Unit start up amps (w/o soft starter - Digit 54=A) (4)	(A)	659.0	596.4	624.9	757.8	790.6	818.4
Unit start up amps (with soft starter - Digit 54=B) (4)	(A)	493.8	478.8	507.3	592.6	625.4	653.2
Displacement power factor	(dpf)	0.87	0.89	0.90	0.89	0.88	0.87
Digit 56 =3							
Maximum Power input	(kW)	195.7	227.8	247.0	261.2	279.0	293.2
Max. amps	(A)	323.9	367.2	395.7	423.5	457.1	484.8
Unit start up amps (w/o soft starter - Digit 54=A) (4)	(A)	662.2	600.4	628.9	761.8	795.4	823.2
Unit start up amps (with soft starter - Digit 54=B) (4)	(A)	497.0	482.8	511.3	596.6	630.2	658.0
Displacement power factor	(dpf)	0.87	0.90	0.90	0.89	0.88	0.87
Compressor							
Compressor Number per Circuit	#	2	3	3	3	3	3
Type		Scroll	Scroll	Scroll	Scroll	Scroll	Scroll
Model Circuit 1 / Circuit 2	kW	40+40/ 40+40	25+30+30/ 25+30+30	30+30+30/ 30+30+30	30+30+40/ 30+30+40	30+40+40/ 30+40+40	40+40+40/ 40+40+40
Max Comp Power input Circuit 1 / Circuit 2	kW	45.2+45.2/ 45.2+45.2	28.4+38.2+38.2/ 28.4+38.2+38.2	38.2+38.2+38.2/ 38.2+38.2+38.2	38.2+38.2+45.2/ 38.2+38.2+45.2	38.2+45.2+45.2/ 38.2+45.2+45.2	45.2+45.2+45.2/ 45.2+45.2+45.2
Rated Amps Circuit 1 / Circuit 2	(A)	75+75/ 75+75	47+61+61/ 47+61+61	61+61+61/ 61+61+61	61+61+75/ 61+61+75	61+75+75/ 61+75+75	75+75+75/ 75+75+75
Locked Rotor Amps Circuit 1 / Circuit 2 (direct start - Digit 54=A)	(A)	413+413/ 413+413	260+294+294/ 260+294+294	294+294+294/ 294+294+294	294+294+413/ 294+294+413	294+413+413/ 294+413+413	413+413+413/ 413+413+413
Locked Rotor Amps Circuit 1 / Circuit 2 (Soft starter - Digit 54=B)	(A)	248+248/ 248+248	156+176/ +176/156 +176+176	176+176 +176/176 +176+176	176+176 +248/176 +176+248	176+248 +248/176 +248+248	248+248 +248/248 +248+248
Motor RPM	(rpm)	2900	2900	2900	2900	2900	2900
Oil sump heater Circuit 1 / Circuit 2	(W)	90+90/ 90+90	90+90+90/ 90+90+90	90+90+90/ 90+90+90	90+90+90/ 90+90+90	90+90+90/ 90+90+90	90+90+90/ 90+90+90
Evaporator							
Quantity	#	1	1	1	1	1	1
Type		Stainless steel Copper Brazed plate Heat exchanger					
Evaporator model		DFX650X222	DFX650X250	DFX650X278	DFX650X278	DFX650X278	DFX650X294
Evaporator Water Content volume	(l)	64.9	73.1	81.3	81.3	81.3	86
Nominal water connection size (Grooved coupling) - Without HYM	(in) - (mm)	4" - 114.3	5" - 139.7	5" - 139.7	5" - 139.7	5" - 139.7	5" - 139.7
Nominal water connection size (Grooved coupling) - With HYM	(in) - (mm)	4" - 114.3	5" - 139.7	5" - 139.7	5" - 139.7	5" - 139.7	5" - 139.7
Maximum pressure on water side without pump package	(BarA)	10	10	10	10	10	10
Hydraulic Module Components							
Single pump - Standard head pressure option							
Max available Head Pressure	(kPa)	157	141	143	182	163	154
Motor Power	(kW)	7.5	7.5	7.5	11.0	11.0	11.0
Rated Amps	(A)	14.4	14.4	14.4	20.8	20.8	20.8



General Data

Table 8 – General data CXAF 130-190 High Efficiency (continued)

		CXAF 130 HE	CXAF 140 HE	CXAF 150 HE	CXAF 165 HE	CXAF 180 HE	CXAF 190 HE
Single pump - High head pressure option							
Max available Head Pressure	(kPa)	232	252	258	249	230	221
Motor Power	(kW)	11.0	15.0	15.0	15.0	15.0	15.0
Rated Amps	(A)	20.8	28.0	28.0	28.0	28.0	28.0
Twin pump - Standard head pressure option							
Max available Head Pressure	(kPa)	157	141	143	182	163	154
Motor Power	(kW)	7.5	7.5	7.5	11.0	11.0	11.0
Rated Amps	(A)	14.4	14.4	14.4	20.8	20.8	20.8
Twin pump - High head pressure option							
Max available Head Pressure	(kPa)	232	252	258	249	230	221
Motor Power	(kW)	11	15	15	15	15	15
Rated Amps	(A)	20.8	28	28	28	28	28
Expansion Tank Volume	(l)	50	50	50	50	50	50
Max User water loop Volume for factory mounted expansion tank (1)	(l)	1750	1750	1750	1750	1750	1750
Optional water Buffer tank volume	(l)	607	777	777	777	777	777
Antifreeze Heater without pump package and without buffer tank	(W)	520	640	640	640	640	640
Antifreeze Heater with pump package and without buffer tank (Single Water Pump digit 24=2 or 4 / Dual Water Pump digit 24=1 or 3)	(W)	1060/1120	1340/1400	1340/1400	1340/1400	1340/1400	1340/1400
Antifreeze Heater with pump package and with buffer tank (Single Water Pump digit 24=2 or 4 / Dual Water Pump digit 24=1 or 3)	(W)	2040/2100	2790/2850	2790/2850	2790/2850	2790/2850	2790/2850
Antifreeze Heater with pump package and with buffer tank (Single Water Pump digit 24=2 or 4 / Dual Water Pump digit 24=1 or 3)	(W)	1940/2000	1940/2000	1940/2000	2040/2100	2040/2100	2790/2850
Condenser							
Type		Fin-tube heat exchanger					
Quantity of coil	#	8	10	10	10	12	12
Face area per circuit	(m ²)	9.29	11.61	11.61	11.61	13.93	13.93
Condenser Fan							
Quantity	#	8	10	10	10	12	12
Diameter	(mm)	800					
Digit 56=1							
Fan / motor Type		Fixed speed AC motor					
Airflow per fan	m ³ /h	17984	18055	18019	17976	18028	17990
Max Power Input per Motor	Kw	1.13	1.13	1.13	1.13	1.13	1.13
Max Amps per Motor	A	2.2	2.2	2.2	2.2	2.2	2.2
Motor RPM	(rpm)	900	900	900	900	900	900
Digit 56=2							
Fan / motor Type		Variable speed EC motor					
Airflow per fan	m ³ /h	18992	17571	18388	18984	17970	18999
Max Power Input per Motor	Kw	1.55	1.55	1.55	1.55	1.55	1.55
Max Amps per Motor	A	2.5	2.5	2.5	2.5	2.5	2.5
Motor RPM	(rpm)	950	880	920	950	900	950
Digit 56=3							
Fan / motor Type		Variable speed EC motor for high external static pressure					
Airflow per fan	m ³ /h	19210	17877	18543	19201	18317	19216
Max Power Input per Motor	Kw	1.82	1.82	1.82	1.82	1.82	1.82
Max Amps per Motor	A	2.9	2.9	2.9	2.9	2.9	2.9
Motor RPM	(rpm)	880	820	850	880	840	880
Dimensions							
Unit Length	(mm)	4520	5645	5645	5645	6770	6770
Unit Width	(mm)	2200	2200	2200	2200	2200	2200
Std Unit Height	(mm)	2526	2526	2526	2526	2526	2526
Pump Package Option - (Additional length configuration)	(mm)	562	562	562	562	562	562
Weights (6)							
Shipping Weight (6)	(kg)	3201	3848	4024	4064	4523	4592

General Data

Table 8 – General data CXAF 130-190 High Efficiency (continued)

		CXAF 130 HE	CXAF 140 HE	CXAF 150 HE	CXAF 165 HE	CXAF 180 HE	CXAF 190 HE
Option Additional shipping weight (6)							
Single pump - Standard head pressure	(kg)	264	287	287	351	401	401
Single pump - High head pressure	(kg)	301	363	363	363	413	413
Twin pump - Standard head pressure	(kg)	363	386	386	495	545	545
Twin pump - High head pressure	(kg)	425	521	521	521	571	571
XLN option	(kg)	114	145	145	145	145	145
Pump VFD option	(kg)	70	70	70	70	70	70
Water Buffer tank option	(kg)	286	379	379	379	379	379
System data							
Nb of refrigerant circuit	#	2	2	2	2	2	2
Minimum cooling load % (6)	%	25	15	17	15	14	17
Total number of capacity steps	#	4	14	6	14	14	6
Standard/Partial Heat Recovery Unit							
R410A refrigerant charge Circuit 1 / Circuit 2	(kg)	50 / 50	67 / 67	67 / 67	67 / 67	77 / 77	78 / 78
R454B refrigerant charge Circuit 1 / Circuit 2	(kg)	43/42	54/53	54/53	54/53	62/61	62/62
Oil charge Circuit 1 / Circuit 2	(l)	17.4 / 17.4	25.4/25.4	25.6/25.6	25.5/25.5	26.3/26.3	26.3/26.3
POE Oil type				OIL058E / OIL057E			

(1) Indicative performance at Evaporator water temperature : 12°C / 7°C - Condenser air temperature 35°C for cooling & Condenser water temperature: 40°C / 45°C - Evaporator air temperature 7°C (6°C) - for detailed performances, on a given unit, consult Order Write Up.
With R454B refrigerant the Capacity/Power input may be reduced by 3%/7% and the efficiencies increase upto 5%.

(2) Under 400V/3/50Hz.

(3) Rated Condition without Pump Package.

(4) Electrical & system data are indicative and subject to change without notice. Please refer to unit nameplate data.

(5) If the power line of the unit is protected by fuses gG of the same size as the disconnect switch.

(6) For detail information refer submittal drawing which are available in the unit.

Typical CGAF / CXAF Components location

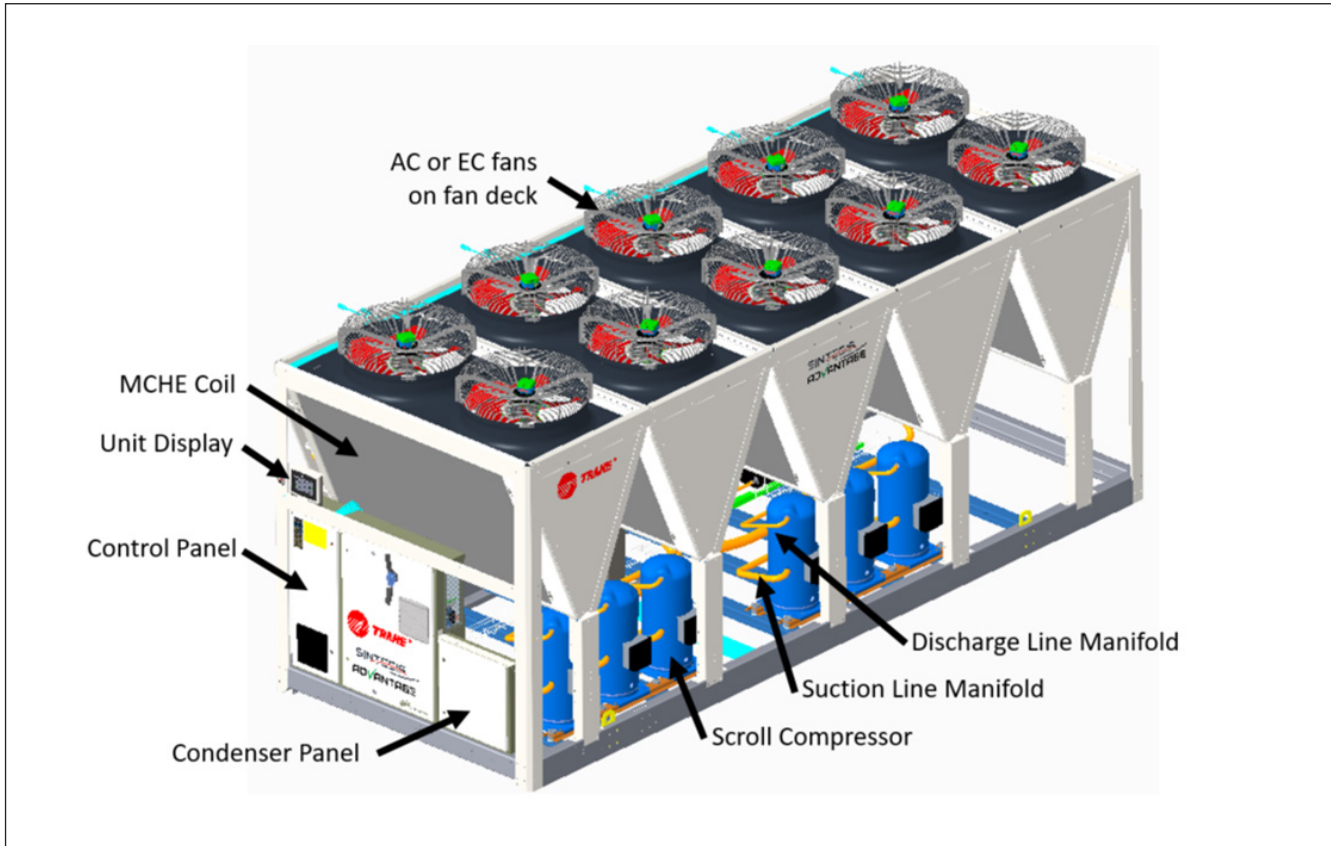

Top view

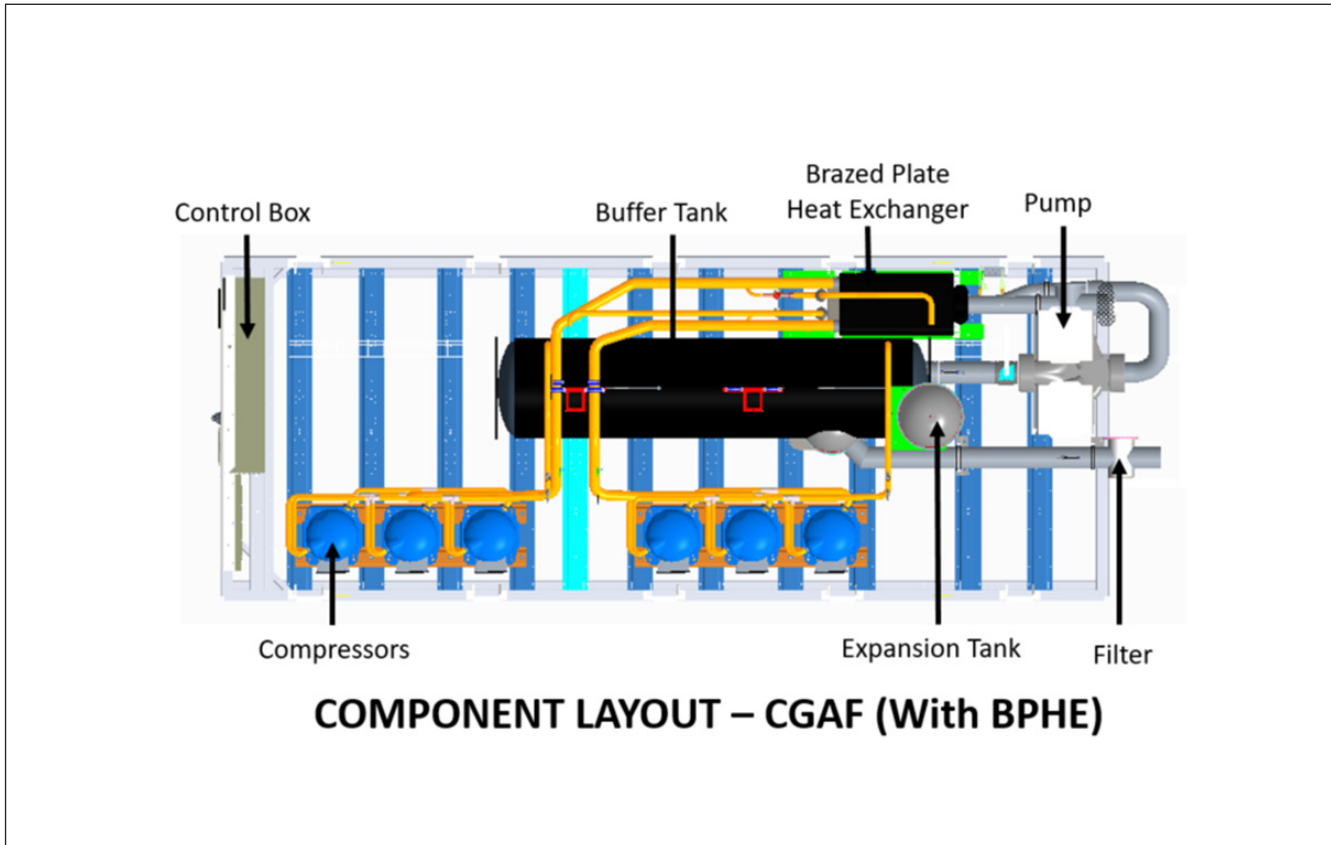

Typical CGAF / CXAF Components location

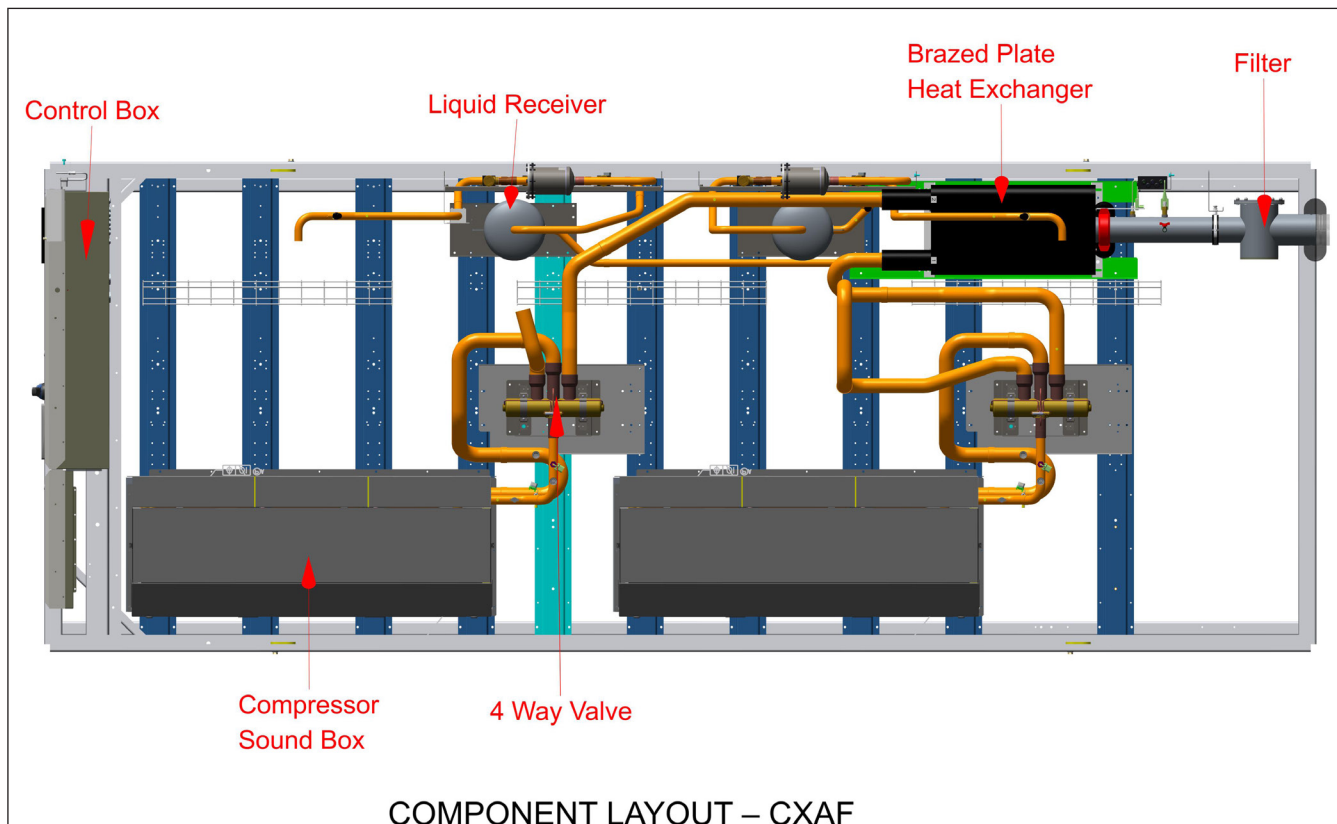
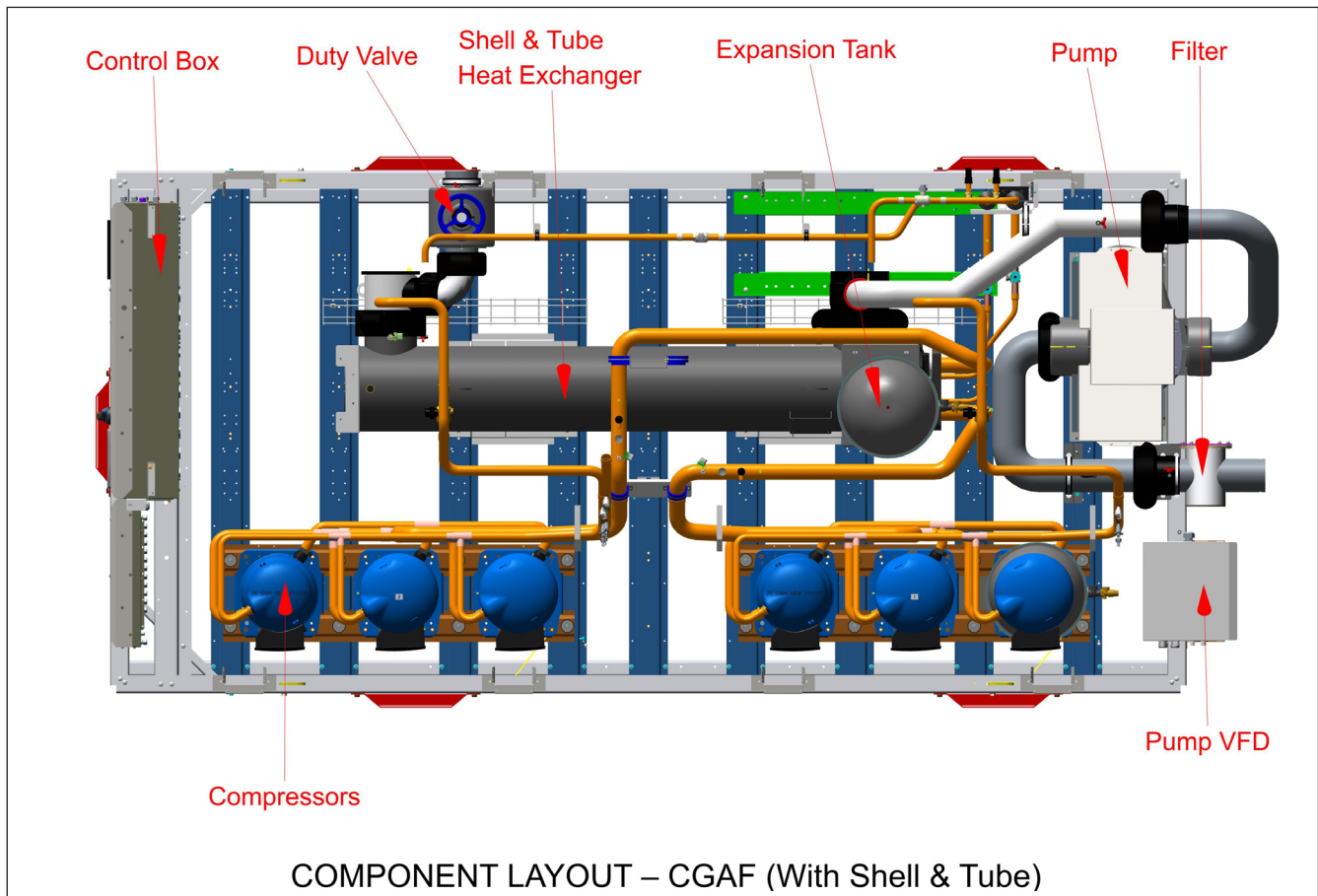

Typical CGAF / CXAF Components location

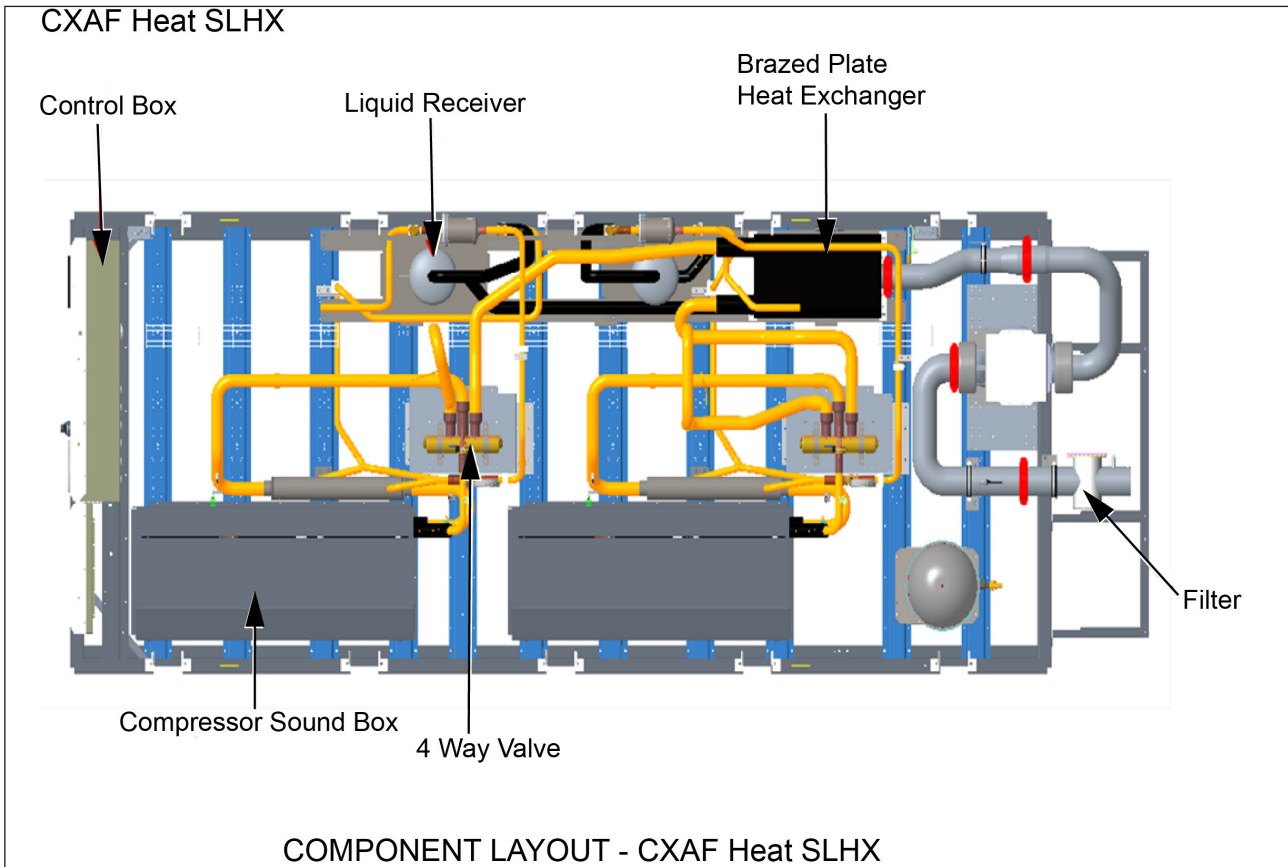

Leak detector Position: CGAF & CXAF: Position is always in-between the 2 compressors manifold.

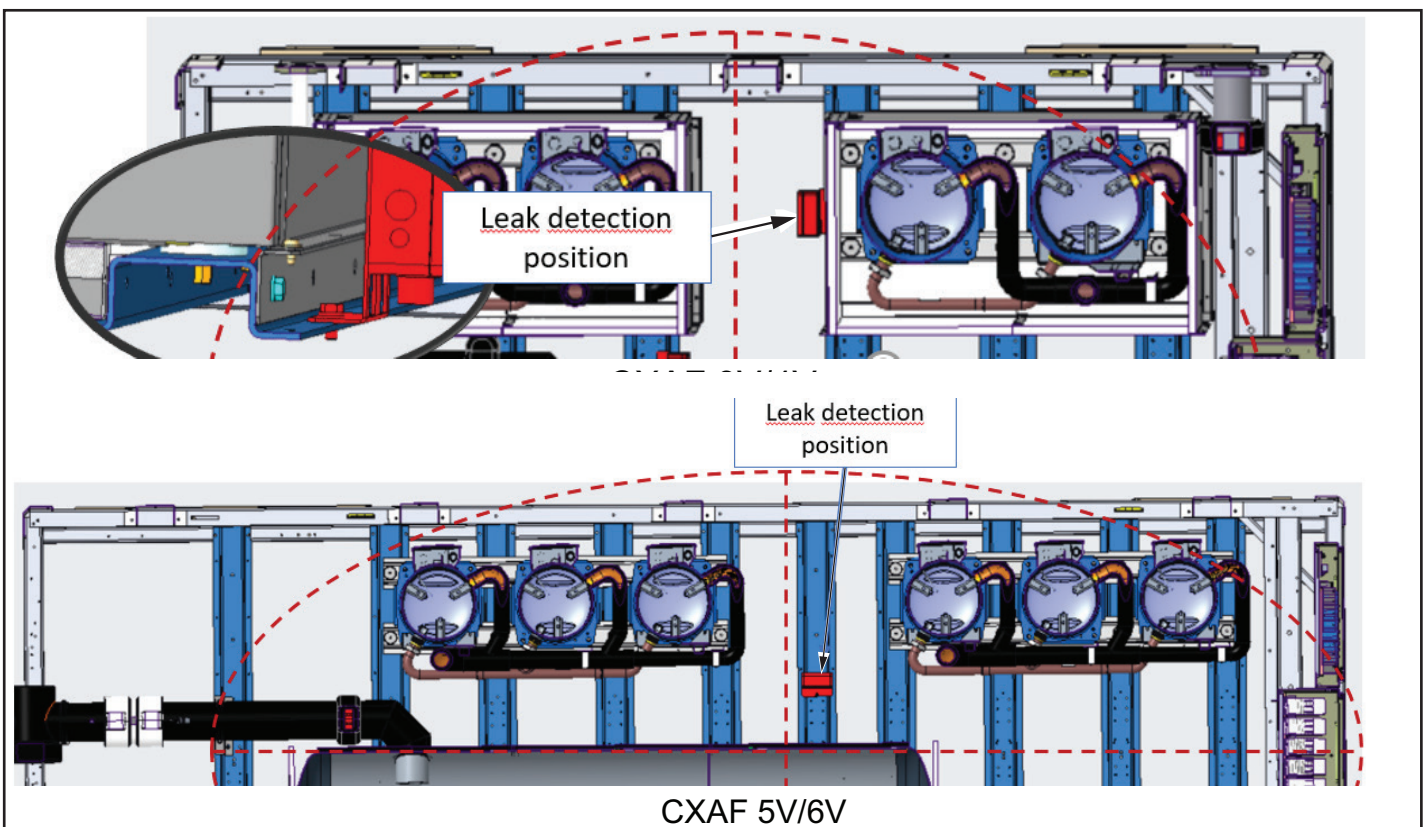

Installation Requirements

Location Requirements

Sound consideration

The most effective form of acoustical isolation is to locate the unit away from any sound sensitive area. Structurally transmitted sound can be reduced by elastomeric vibration eliminators. Spring isolators are not recommended. Consult an acoustical engineer in critical sound applications.

For maximum isolation effect, isolate water lines and electrical conduit. Rubber isolated piping hangers can be used to reduce the sound transmitted through water piping. To reduce sound transmitted through electrical conduit, use flexible electrical conduit.

EU and Local Regulations codes on sound emissions should always be considered. Since the environment in which a sound source is located affects the sound pressure, unit placement must be carefully evaluated.

Clearances

When installing the unit, provide enough space around the unit to allow the installation and maintenance personnel unrestricted access to all service points.

Unobstructed flow of condenser air is essential to maintain chiller capacity and operating efficiency. When determining unit placement, give careful consideration to ensuring a sufficient air flow across the condenser coils heat-transfer surface.

In case of enclosure around the unit, the height of the enclosure must not be higher than the unit itself. If the enclosure is higher than the unit, restrictive airflow louvers should be fitted to ensure fresh air supply.

Installation Responsibilities

Generally contractor must do the following items when installing a CGAF / CXAF unit:

1. Install the unit on a flat foundation strong enough to support unit loading and level (within 5 mm across the length and width of the unit).
2. Install the units as per instructions contained in this manual.
3. Where specified, provide and install valves in the water piping upstream and downstream of the evaporator water connections, to isolate the evaporator for maintenance, and to balance and trim the system.
4. Furnish and install a water flow prove device and/or auxiliary contacts to prove chiller water flow.
5. Furnish and install water pressure gauges in

the inlet and outlet of the evaporator water box.

6. Supply and install an air vent cock to the top of the evaporator or evaporator piping.
7. Furnish and install strainers ahead of all pumps and automatic modulating valves.
8. Provide and install field wiring according to schematics provided in the control panel.
9. Install heat tape and insulate the chilled water lines and any other portion of the system, as required, to prevent sweating under normal operating conditions or freezing during low ambient temperature conditions.
10. Ensure that the compressor and compressor heaters have been operating for a minimum of 24 hours before starting. Failure to do so may result in equipment damage.
11. Start the unit under supervision of a qualified service technician.

Lifting and Moving Instructions

A specific lifting method is recommended, which can be described as follow:

1. Lifting points are built into the unit, see lifting instruction label on the unit.
2. Slings and spreader bar must be provided by crane operator and attached on the lifting points.
3. Use the 4 rigging points which are built into the unit.
4. The minimum lifting capacity of each sling as well as the spreader bar must be higher than the tabulated unit shipping weight.

CAUTION! Lift and handle with care. Avoid shocks while handling.

Details of lifting instruction and container pull out are given in the drawings specific for lifting and handling shipped with the unit.

WARNING! Heavy Objects! Ensure that all the lifting equipment used is properly rated for weight of the unit being lifted. Each of the cables (chains or slings), hooks, and shackles used to lift the unit must be capable of supporting the entire weight of unit. Lifting cables (chains or slings) may not be the same length. Adjust as necessary for even unit lift. Other lifting arrangements could cause equipment or property damage. Failure to follow instructions above or properly lift unit could result in unit could result in unit dropping and possibly crushing operator/ technician which could result in death or serious injury.

Installation Requirements

WARNING! Improper Unit Lift! Test lift unit approximately 10 cm to verify proper center of gravity lift point. To avoid dropping of unit, reposition lifting point if unit is not level. Failure to properly lift unit could result in unit dropping and possibly crushing operator/technician which could result in death or serious injury and possible equipment or property- only damage.

Dimension and Weights

Dimensions details, dimensions of hydraulic connections, electrical connections, isolator positioning, specific features for heat recovery and free-cooling are included in submittals and diagrams provided in documentation package.

Center of Gravity

See instructions on lifting drawings, available on request.

Unit Isolation and Levelling

Provide a foundation with sufficient strength and mass to support the unit operating weight (that is, including completed piping, full operating charges of refrigerant and oil, and water). Refer to unit operating weights. The unit must be levelled within 5 mm over its length and width. Use shims as necessary to level the unit. For additional reduction of sound and vibration, install the optional elastomeric isolators.

Elastomeric Isolators Installation (Optional)

Isolators are ready to install. Mountings have to be placed on a rigid and level foundation. External equipment should not transmit additional vibration to the chiller. The position of elastomeric isolator and weight per point are given in the Neoprene isolators installation drawing which is supplied with the chiller. Wrong placement along the unit may result in excessive deflection.

1. Secure the isolators to the mounting surface using the mounting slots in the isolator's base plate. Do NOT fully tighten the isolators mounting bolts at this time. See the isolators submittals for isolators location, maximum weights, and isolators diagrams.
2. Align the mounting holes in the base of the unit with the threaded positioning pins on the top of the isolators.
3. Install the unit on the isolators and secure the isolators to the unit with a nut. The maximum isolators deflection should be 13 mm.
4. Level the unit carefully. Fully tighten the isolator mounting bolts.

Figure 2 – Elastomeric Isolator

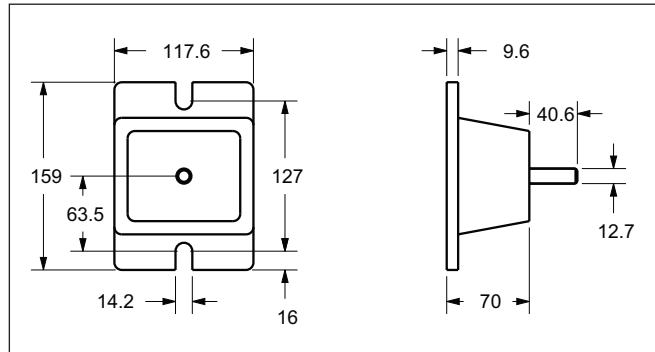

Isolator Pads Installation (Optional)

Isolators are ready to install. Mountings have to be placed on a rigid and level foundation. External equipment should not transmit additional vibration to the chiller. The position of pads isolator is given in the pad isolators installation or selection drawing which is supplied with the chiller.

Figure 3 – Isolator pads

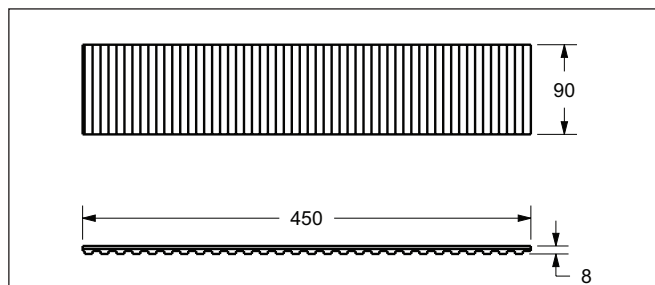

Evaporator Piping

Evaporator water connections are grooved. Thoroughly flush all water piping to the unit before making the final piping connections to the unit. Components and layout will vary slightly, depending on the location of connections and the water sources.

CAUTION Equipment Damage! If using an acidic commercial flushing solution, construct a temporary bypass around the unit to prevent damage to internal components of the evaporator.

CAUTION Proper Water Treatment! The use of untreated or improperly treated water in a chiller may result in scaling, erosion, corrosion, algae or slime. It is recommended that the service of a qualified water treatment specialist be engaged to determine what water treatment, if any, is required. Trane assumes no responsibility for equipment failures which results from untreated or improperly treated water or saline or brackish water.

Drainage

Locate the unit near a large capacity drain for water vessel draining down during shutdown or repair. Condensers and evaporators are provided with drain connections. Refer to "Water Piping." All local and national codes apply.

Water Treatment

In the evaporator the following material are in contact with water:

- Plate material: AISI 316 EN 10028-7 - 1.4401 +2B/2R
- Connection: AISI 316 EN 10272 - .4401/1.4404/1.4435/1.4436 - 1E
- Braze alloy: EN-13388, ISO Copper CU-HCP

In Shell and Tube evaporator the following material are in contact with water:

- Copper tube
- Carbon steel
- Polypropylene baffles
- EPDM rubber gaskets on baffles
- Stainless steel rivets
- Tie rod in carbon steel with galvanized finish

for the heater, the copper ring gaskets.

When the unit is supplied with hydraulic module, the following additional materials are in contact with water:

- Pump frame and connections are made of cast iron

- Water pipes are made of carbon steel
- Pipe sealings are made of EPDM rubber (ethylene propylene diene monomer rubber)
- Pump sealings are made of silicon carbide
- Strainer is made of stainless steel

Dirt, scale, products of corrosion and other foreign material will adversely affect heat transfer between the water and system components. Foreign matter in the chilled water system can also increase pressure drop and consequently, reduce water flow. Proper water treatment must be determined locally, depending on the type of system and local water characteristics.

Neither salt nor brackish water is recommended for use in Trane air-cooled chillers. Use of either will lead to an unpredictably shorter life cycle. Trane encourages the employment of a reputable water treatment specialist, familiar with local water conditions, to assist in this determination and in the establishment of a proper water treatment program.

If calcium chloride is used for water treatment, an applicable corrosion inhibitor must also be used. Failure to do so may result in damage to system components. Do not use untreated or improperly treated water. Equipment damage may occur.

Standard Piping

Piping components include all devices and controls used to provide proper water system operation and unit operating safety.

Reverse Water Flow Piping

Water flow direction on evaporator is from up to down for units in standard efficiency and water flow direction is from down to up for units with heat option.

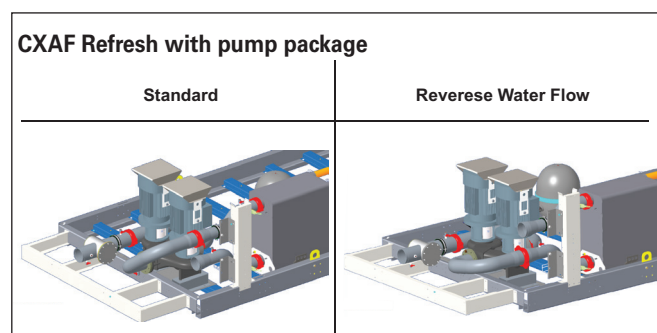
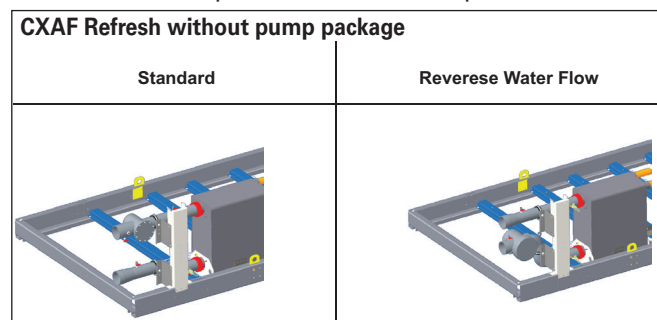

Evaporator Piping

A typical CGAF / CXAF evaporator piping instrumentation is shown below.

Figure 4 – Unit typical water circuit

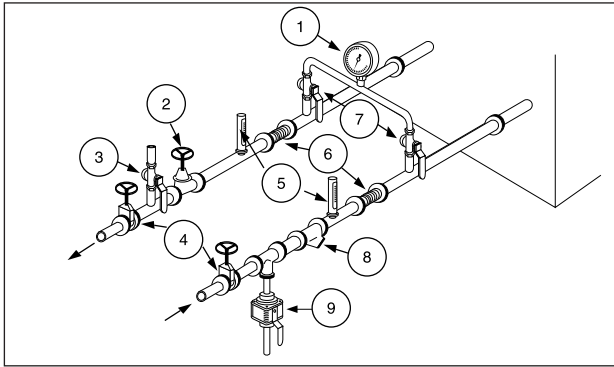

- 1 = Pressure gauges: shows entering and leaving water pressure
- 2 = Balancing valve: adjusts water flow.
- 3 = Air purge allows to remove the air from the water circuit during fill up.
- 4 = Stop valves: isolate chillers and water circuiting pump during maintenance operations.
- 5 = Thermometers: indicate chilled water entering and leaving temperatures.
- 6 = Expansion compensators: avoid mechanical stress between chiller and piping installation.
- 7 = Stop valve located on the outlet connection: used to measure the water pressure inlet or outlet of evaporator.
- 8 = Strainer: avoid to get heat exchangers dirty. All installation must be equipped with efficient strainer in order that only clean water enters into exchanger. If there is no strainer, reserve will be formulated by the Trane technician at the start-up of the unit. The trainer used must be able to stop all particles with a diameter greater than 1 mm.
- 9 = Draining: used as the draining the plate heat exchanger.
- 10 = Do not start the unit with low water volume or not enough pressurized circuit.

Note: A pressure switch device to detect lack of water is not included in the pump package. Installation of this type of device is highly recommended to avoid sealing damage due to operation of pump without enough water.

An air vent is located on top of the evaporator at the chiller water outlet. Be sure to provide additional air vents at the highest points in the piping to remove air from the chilled water system. Install necessary pressure gauges to monitor the entering and leaving chilled water pressure.

Provide shut off valves in lines to the gauges to isolate them from the system when they are not in use. Use rubber vibration eliminators to prevent vibration transmission through the water lines. If desired, install thermometers in the lines to monitor entering and leaving water temperatures.

Install a balancing valve in the leaving water line to control water flow balance.

Install shut-off valves on both the entering and leaving water lines so that the evaporator can be isolated for service.

It is mandatory to place a flow switch device at the outlet of the unit and to link it with the control of the unit (see wiring diagrams shipped with the unit).

CAUTION! The chilled water connections to the evaporator are to be “grooved pipe” type connections. Do not attempt to weld these connections, because the heat generated from welding can cause microscopic and macroscopic fractures on the heat exchanger connection that can lead to premature failure of the connection. An optional grooved pipe stub and coupling should be used for welding on flanges.

To prevent damage to chilled water components, do not allow evaporator pressure (maximum working pressure) to exceed 10 Bar. The maximum service pressure depends on free-cooling type and potential pump package option. The value of max service pressure is indicated on unit nameplate.

Entering Chilled Water Piping

- Air vents to bleed the air from the system (to be placed on the highest point)
- Water pressure gauges with shut-off valves
- Vibration eliminators
- Shut-off (isolation) valves
- Thermometers if desired (temperature readings available on chiller controller display)
- Clean-out tees
- Pipe strainer

Leaving Chilled Water Piping

- Air vents to bleed the air from the system (to be placed on the highest point)
- Water pressure gauges with shut off valves
- Vibration eliminators
- Shut-off (isolation) valves
- Thermometers (temperature readings available on the chiller controller display)
- Clean-out tees
- Balancing valve
- Flow Proving Device

Pressure Gauges

Install field-supplied pressure components. Locate pressure gauges or taps in a straight run of pipe; avoid placing them near elbow (at least at 10 pipe diameter from discontinuity).

Evaporator Piping

To read manifold pressure gauges, open one valve and close the other (depending on the side of the desired reading), this eliminates errors resulting from differently calibrated gauges installed at unmatched elevations.

Evaporator Flow Switch

Specific connection and schematic wiring diagram are shipped within the unit. Some piping and control schemes, particularly those using a single water pump for both chilled and hot water, must be analysed to determine how and/or if a flow sensing device will provide the desired operation.

Flow Switch Installation – Typical Requirements

1. Mount the switch upright, with a minimum of 10 pipe diameters of straight horizontal run on each side. Do not install close to elbows, orifices, or valves. The arrow on the switch must point in the direction of the flow. For additional information, consult the flow switch information sheet coming with the part.
2. To prevent switch fluttering, remove all air from the water system. Tracer™ UC800 /Symbio800 provides a 6 second time delay after a “loss-of-flow” diagnostic before shutting the unit down. Contact a Trane service representative if nuisance machine shutdowns persist.
3. Adjust the switch to open when water flow falls below nominal values. Evaporator data is given on the General Information Section. Flow Switch contacts are closed on proof of water flow.

CAUTION! Control voltage from the chiller to the flow proving device is 110V AC.

Note: In case of winter water drainage for freeze protection, it is mandatory to disconnect the evaporator heaters to protect them from burning due to overheat. It is also mandatory to fulfill the drainage, using pressurized air, and ensure that no water stays in the evaporator during winter season.

Minimal Installation Water Content

The water volume is an important parameter because it allows as table chilled water temperature and avoids short cycle operation of the compressors.

Parameters which influence the water temperature stability

- Water loop volume
- Load fluctuation
- Number of capacity steps
- Compressors rotation
- Dead band (adjusted on chiller controller)
- Minimum time between 2 starts of a compressor

Minimum Water Volume for a Comfort Application

For comfort application we can allow water temperature fluctuation at part load. The parameter to take into account is the minimum operating time of the compressor. In order to avoid lubrication problem on a scroll compressor it must run at least 2 minutes (120 seconds) before it stops.

The minimum volume can be determined by using the following formula:

Volume = Cooling capacity x Time x highest capacity step (%) / Specific heat / Dead band

Minimum operating time = 120 seconds

Specific heat = 4.18 kJ / kg

Average Dead band = 3°C (or 2°C)

Note: To estimate the biggest step, it is usually more reliable to make a selection at lower ambient temperature where efficiency is higher and compressors steps bigger. It is also essential to take into account the brine specific heat, in case of the use of glycol. Process applications will need more water volume to minimize the water temperature fluctuation at part load.

Expansion Tank (option)

The factory-installed expansion tank initial pressure should be adjusted about 0.2 bar lower than the static pressure of the circuit at the pump inlet. The expansion tank volume has been selected for typical loop volume.

It is recommended to check the expansion tank volume with the installation information.

The following data is required:

C = Water capacity of the circuit

e = Expansion coefficient (difference between max and min water temperature, in operation or not)

Pi = Initial pressure of the expansion tank

Pf = Final pressure: Max is given by the pressure relief valve

Minimum Volume of expansion tank = $(C \times e) / (1 - P_i / P_f)$

Expansion coefficient of water various temperatures

°C	e
0	0.00013
10	0.00027
20	0.00177
30	0.00435
40	0.00728
50	0.01210

Water loop and expansion tank volume

- Water loop CGAF 080 HE/XE, CGAF 090: **607 l**

- Water loop CGAF 140-190: **777 l**

Expansion tank volume (option): **50 l**

Note: Maximum pressure of the circuit is 400 kPa with pump package and 1000 kPa without.

Installation - Mechanical

Figure 5 – CGAF / CXAF Evaporator Water Pressure Drop (BPHE, Shell & Tube)

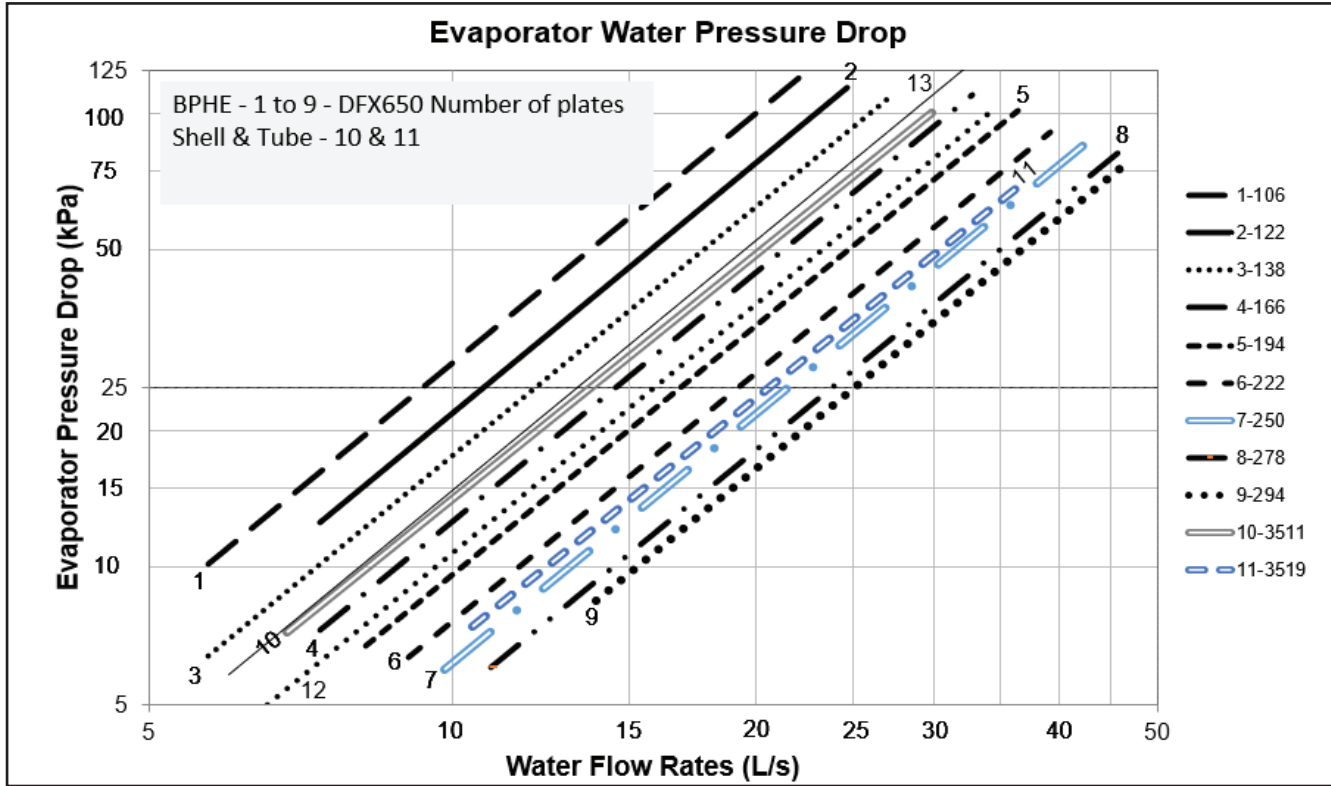

Note: Water pressure drop are for pure water. Limit of water flow are limit of the curves.

Schematic pump package

Installation – Mechanical

Chiller can be ordered with an optional integrated hydraulic module. In this case, chiller will be provided with the following components factory mounted and tested:

- Centrifugal water pump, Low pressure or High pressure (option)
- Water strainer to protect the pump against impurities in the circuit
- Expansion module with expansion vessel and pressure relief valve sufficient to ensure the expansion of the water loop ability
- Thermal insulation for antifreeze protection
- Balancing valve (optional) for equilibrate the flow of water circuit
- Drain valve
- Temperature sensor

Note: A pressure switch device to detect lack of water is not included in the pump package. Installation of this type of device is highly recommended to avoid sealing damage due to operation of pump without enough water. Pump package schematics is supplied in the documentation set shipped with the unit.

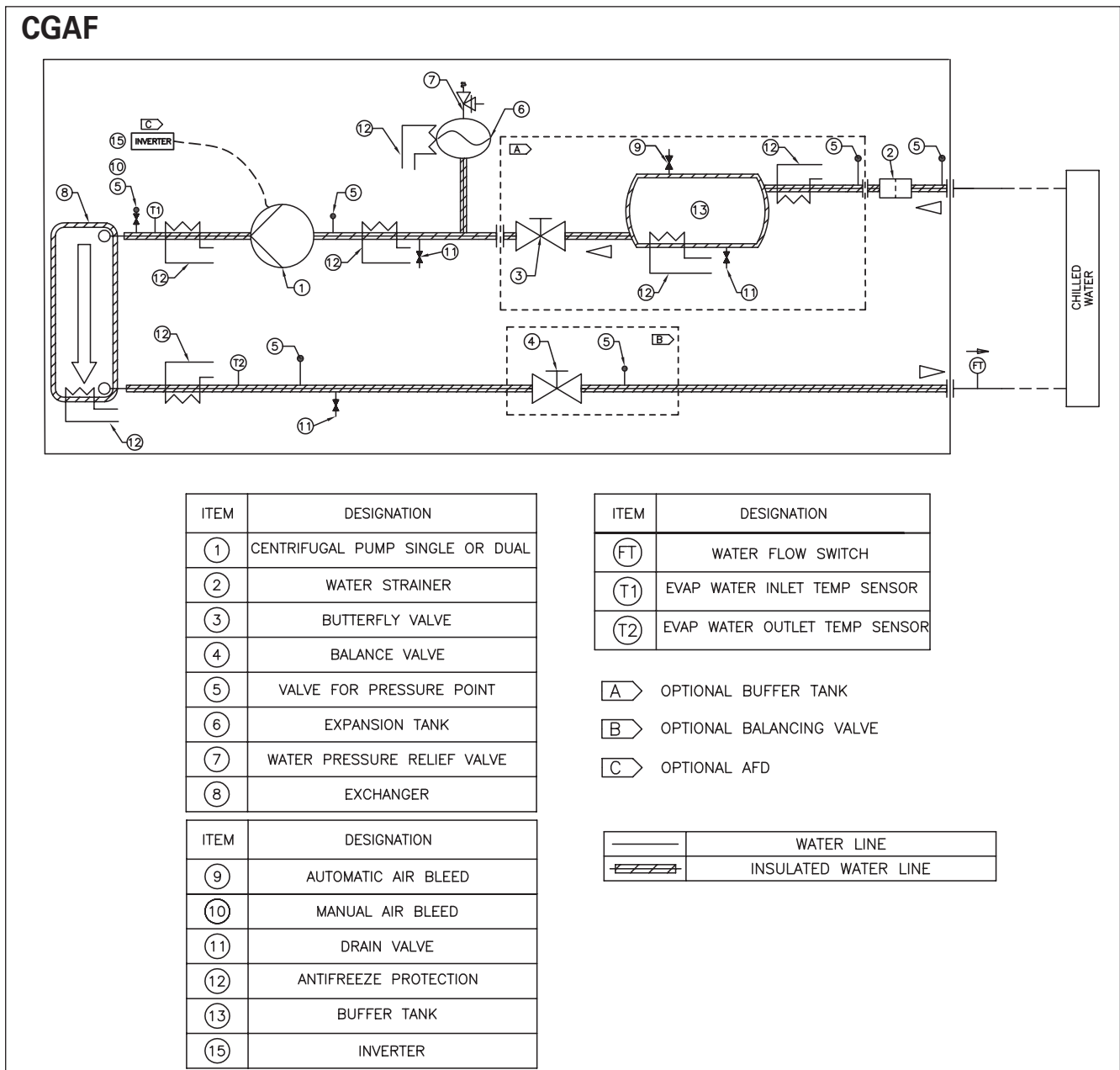

Schematic pump package

CXAF

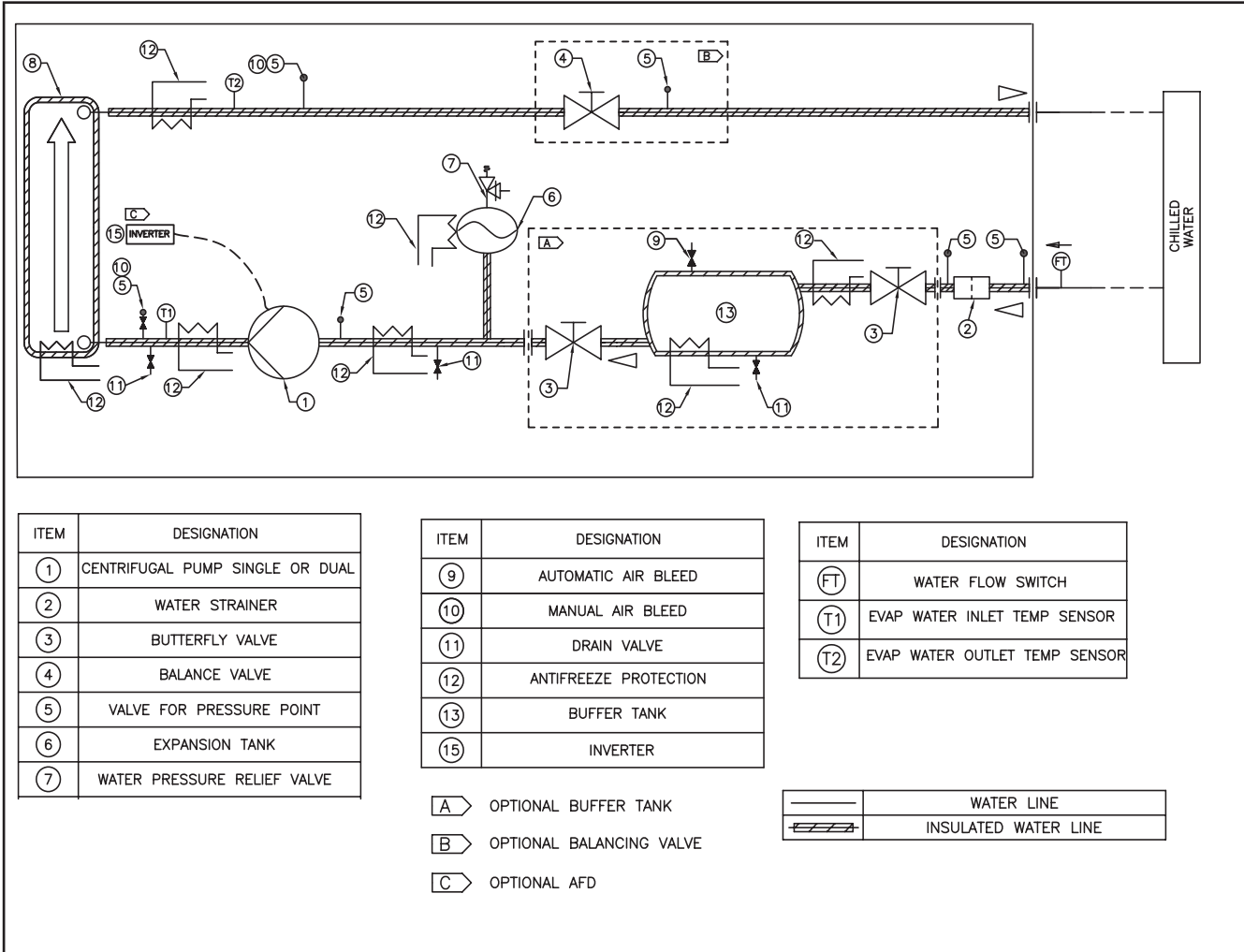

Schematic pump package

Pump Curves

In the figures below are described pump curves (Standard Head and High head) for the whole CGAF / CXAF unit range.

Figure 6 – Pump Curve - Sizes 090-190 –Standard / High Head - BPHE / Shell & Tube Evaporator

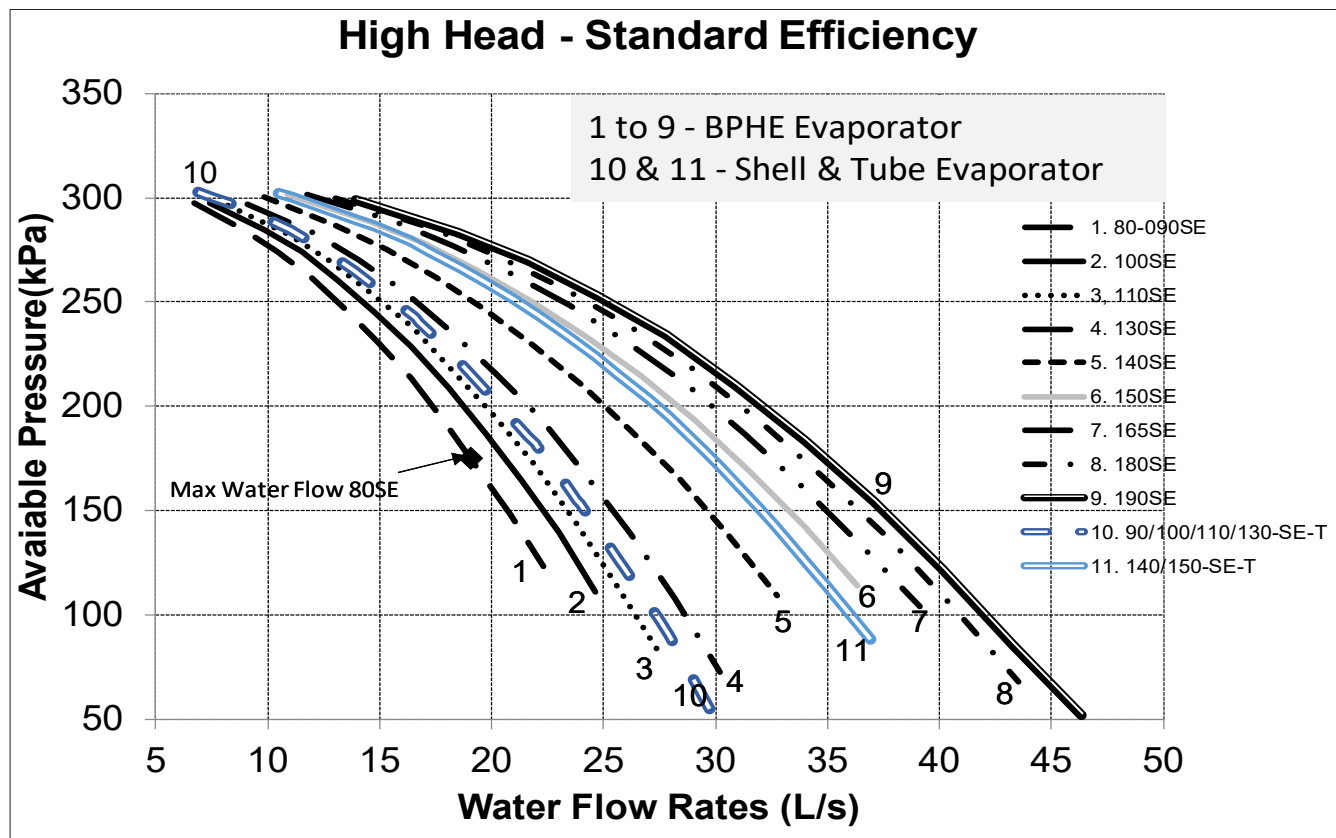
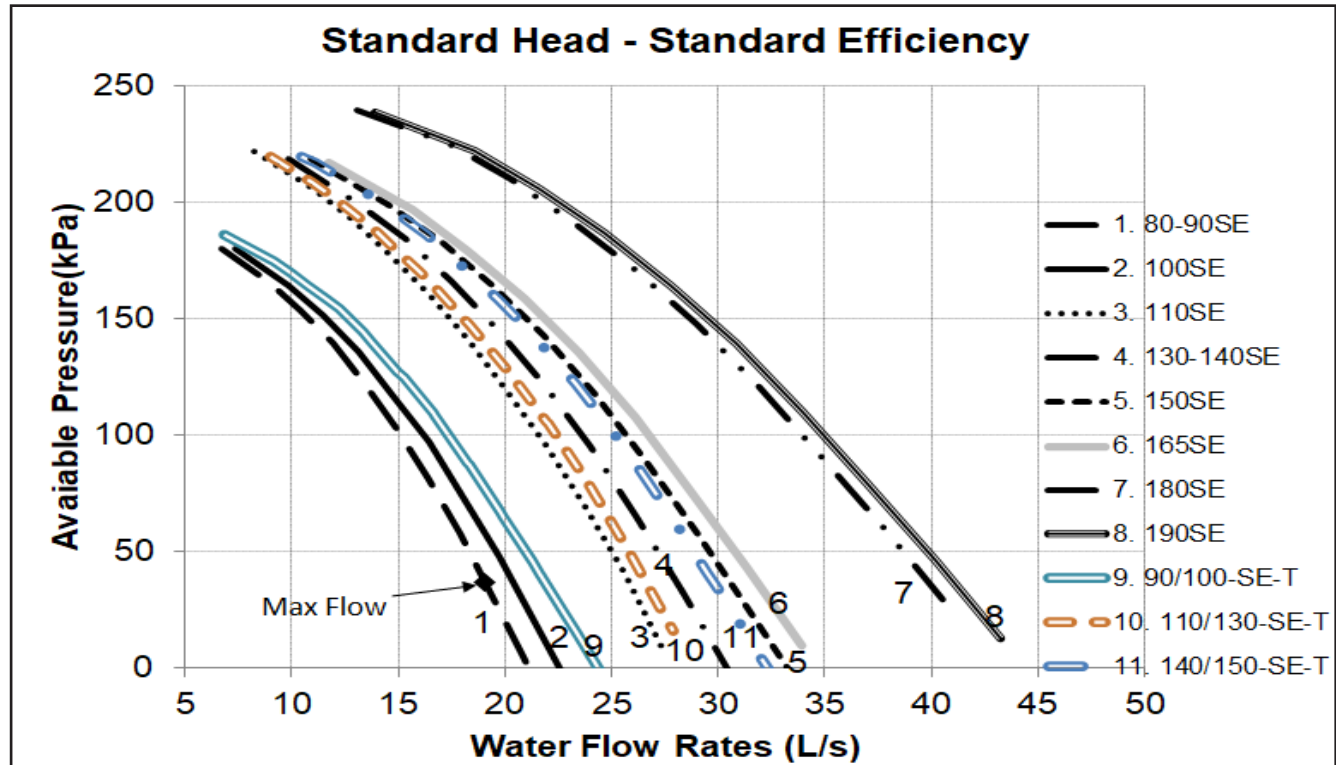

Schematic pump package

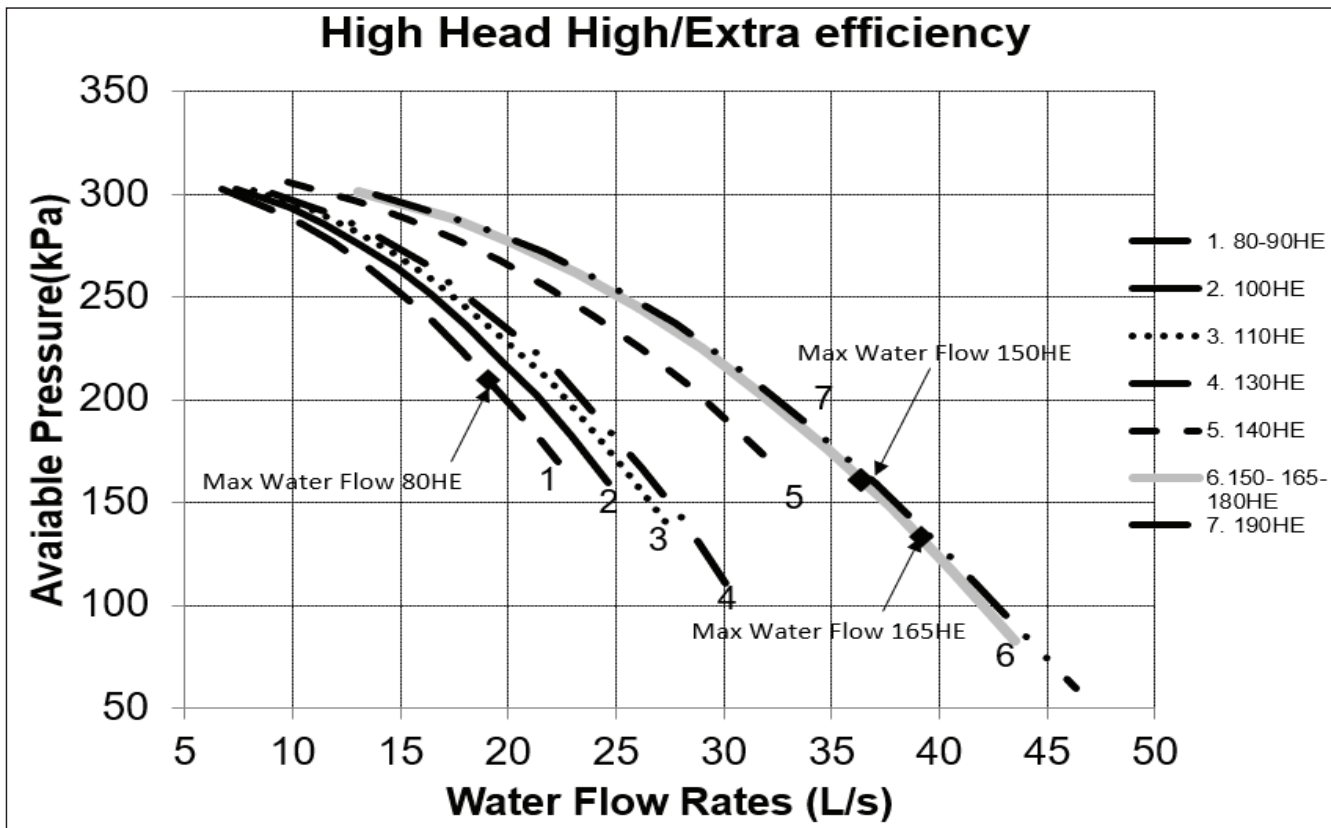
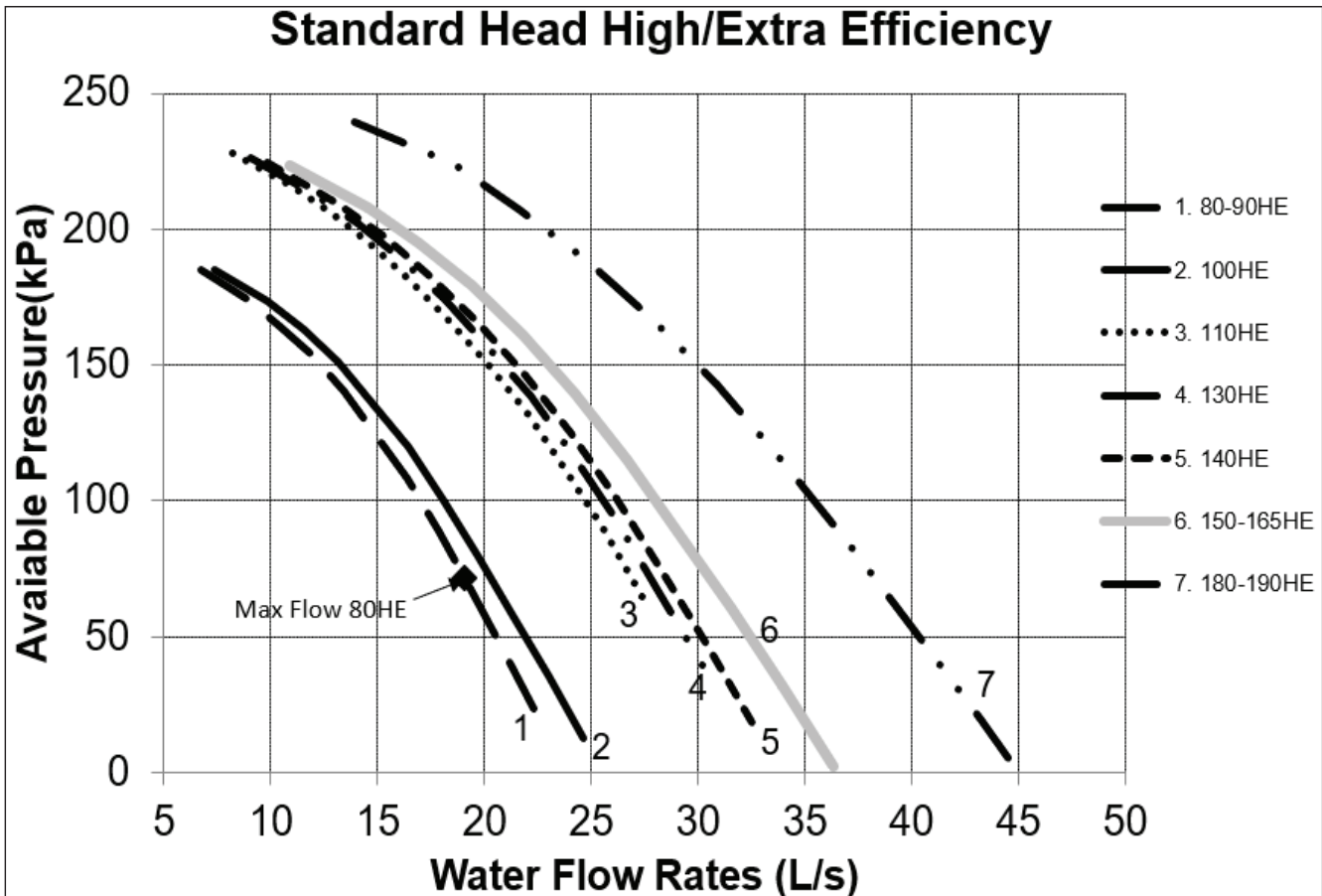



Evaporator Waterside

Freeze Protection

Depending on the ambient temperature the unit may be exposed to freeze, there are multiple options for freeze protection. They are listed in order of highest ambient (least freeze protection) to the lowest ambient (most freeze protection).

For all chiller running with water under cold ambient temperature (below 0°C), it is extremely important to keep full water flow in the evaporator for an extended time after last compressor stops. This will protect brazed plate evaporator from freezing by refrigerant migration. This is why evaporator water pump output relay must be used to control the chilled water pump. This is not mandatory if glycol is used with protection down to lowest ambient expected.

1. Water Pump and Heaters

- a. Heaters are factory installed on brazed plates evaporator. They will protect it from freezing in ambient temperatures down to -18°C. Heaters are installed on the water piping and on the pumps of units equipped with hydraulic module.
- b. Install heat tape on all water piping, pumps, and other components that may be damaged if exposed to freezing temperatures. Heat tape must be designed for low ambient temperature applications. Heat tape selection should be based on the lowest expected ambient temperature.
- c. Tracer™ UC800 /Symbio800 controller can start the pump(s) when freezing conditions are detected. For this option the pumps must be controlled by the CGAF / CXAF unit and this function validated on the chiller / Heat pump controller.
- d. Water circuit valves need to stay open at all times.

Note: Water pump control and heater combination will protect the evaporator down to any ambient temperature provided power is available to the pump and the Tracer™ UC800 /Symbio800 controller. This option will NOT protect the evaporator in the event of power failure to the chiller unless backup power is supplied to the necessary components.

OR

2. Freeze Inhibitor

- a. Freeze protection can be accomplished by adding sufficient glycol to protect against freezing down to the lowest ambient expected.
- b. See “evaporator glycol requirement” section for guidance on determining the glycol concentration.

Note: Use of glycol type antifreeze reduces the cooling capacity of the unit and must be considered in the design of the system specifications.

CAUTION! When using freeze inhibitor, never fill the system with pure glycol. Always fill the system with diluted solution.

Maximum concentration of glycol is 40%. Higher glycol concentration will damage pump seal.

OR

3. Drain Water Circuit

For ambient temperatures below -20°C and for those installation not including either option 1 or 2 above described

- a. Shut off power supply to unit and to all heaters.
- b. Purge the water circuit
- c. Blow out the evaporator to ensure that no liquid is left inside the evaporator and the water lines. Drain the pump.

Note: It is not recommended to drain the water circuit for the following reasons.

1. The water circuit will rust and its lifetime could be reduced.
2. Water will remain in the bottom of the plate heat exchangers and freeze damage could occur

CAUTION! Evaporator damage!

If insufficient concentration or no glycol is used, the evaporator water pumps must be controlled by the Tracer™ UC800/Symbio800 to avoid severe damage to the evaporator due to freezing. A power loss of 15 minutes during freezing can damage the evaporator. It is the responsibility of the installing contractor and/or the customer to ensure that a pump will start when called upon by the chiller controls. Please consult TRANE service for unit setting and % of glycol required.

With factory-fitted disconnect switch option, evaporator trace heating is taken from the live side of the isolator. As a consequence, the heaters are energized as long as the main switch is closed. Supply voltage to the heating tapes is 400V.

- Avoid the use of very low or near minimum chilled fluid flow rates through the chiller. Higher velocity chilled fluid flow reduces freeze risk in all situations.
- Flow rates below limits have increased freeze potential and have not been considered by freeze protection algorithms.
- Avoid applications and situations that result in a requirement for rapid cycling or repeated starting and stopping of the chiller. Keep in mind that chiller control algorithms may prevent a rapid compressor restart after shutting down when the evaporator has been operating near or below the LERTC (Low Refrigerant Temperature Cutout) limit.
- Maintain refrigerant charge at appropriate levels. If charge is in question, contact Trane service. A reduced or low level of charge can increase the likelihood of freezing conditions in the evaporator and/or LERTC diagnostic shutdowns.

The warranty will be void, in case of freezing due to the lack of use of either of these protections.



Evaporator Waterside (not for free-cooling version)

Low Refrigeration Temperature Setpoint and Antifreeze Setpoint on CGAF and CXAF Unit Control

CAUTION! The chiller is provided with standard factory settings. It can be necessary to modify the low refrigerant cutout temperature and the antifreeze setpoint on the unit control. Based on the following examples, it is necessary to modify on the unit control the following settings:

- The LP saturation temperature
- The antifreeze setpoint

Examples for:

- 7°C, the LRTC setting must be -4°C where the antifreeze setting shall be 2°C
- 0°C, the LRTC setting must be -12°C where the antifreeze setting shall be -6°C

Freeze Protection with Glycol

It is mandatory to use a freeze inhibitor for leaving water setpoint less or equal to 5°C. On the glycol recommended concentration figure, you must select concentration on or above the curve. For example, for -4°C brine temperature, a concentration of 25% ethylene glycol is not sufficient. The concentration must be 28% ethylene glycol or 33% propylene glycol.

Using Glycol with Hydraulic Module

If the glycol brine percentage is not at the recommended percentage (greyed area), corrosion inhibitor present in the glycol may not be efficient enough. For instance, a glycol concentration of 15% will provide freeze protection to the unit down to -5°C, but it might generate additional corrosion.

Figure 7 – Low refrigerant cutout temperature setpoint and antifreeze water temperature based on active chilled water setpoint

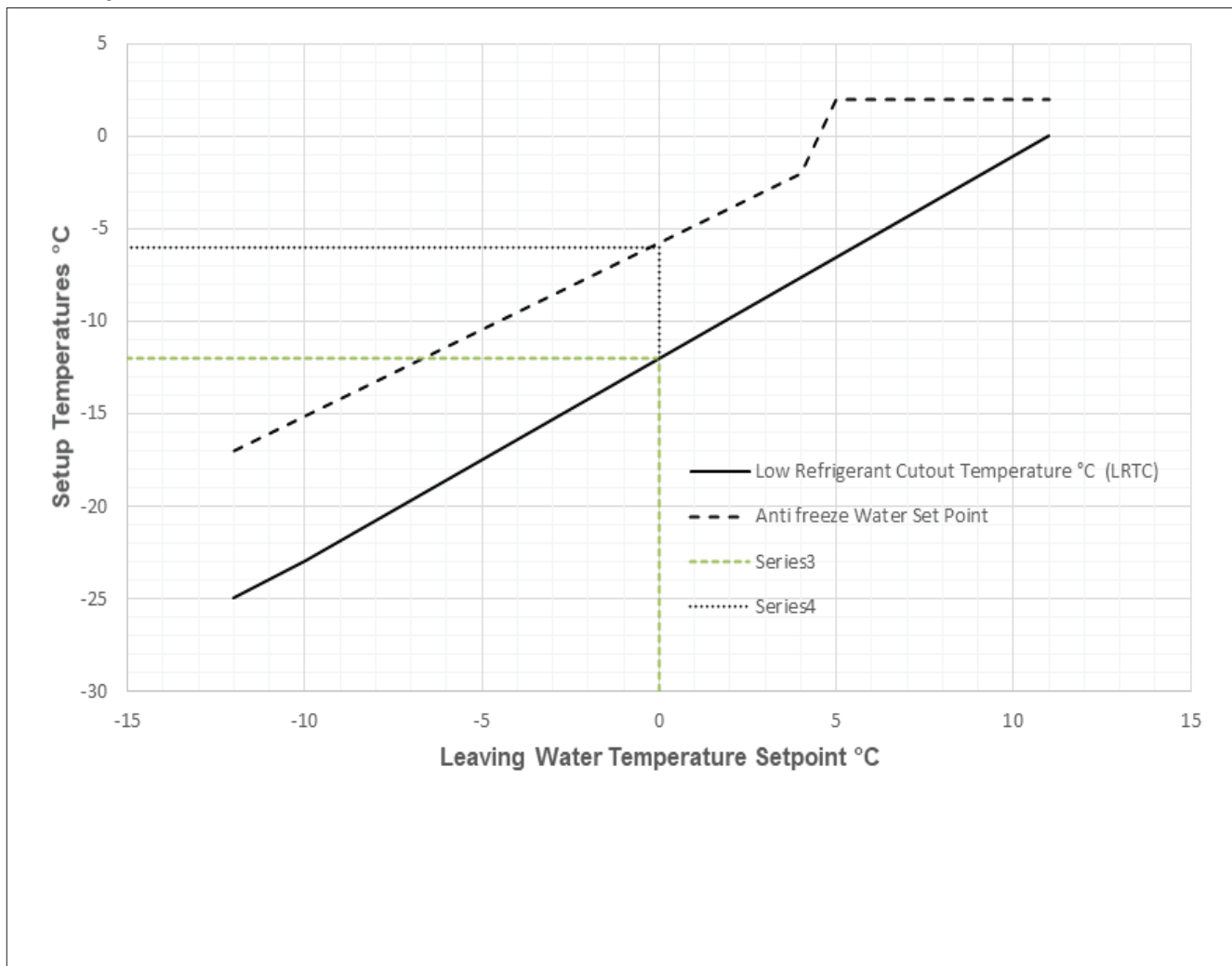

Evaporator Waterside (not for free-cooling version)

Figure 8 – Glycol percentage recommendation curve

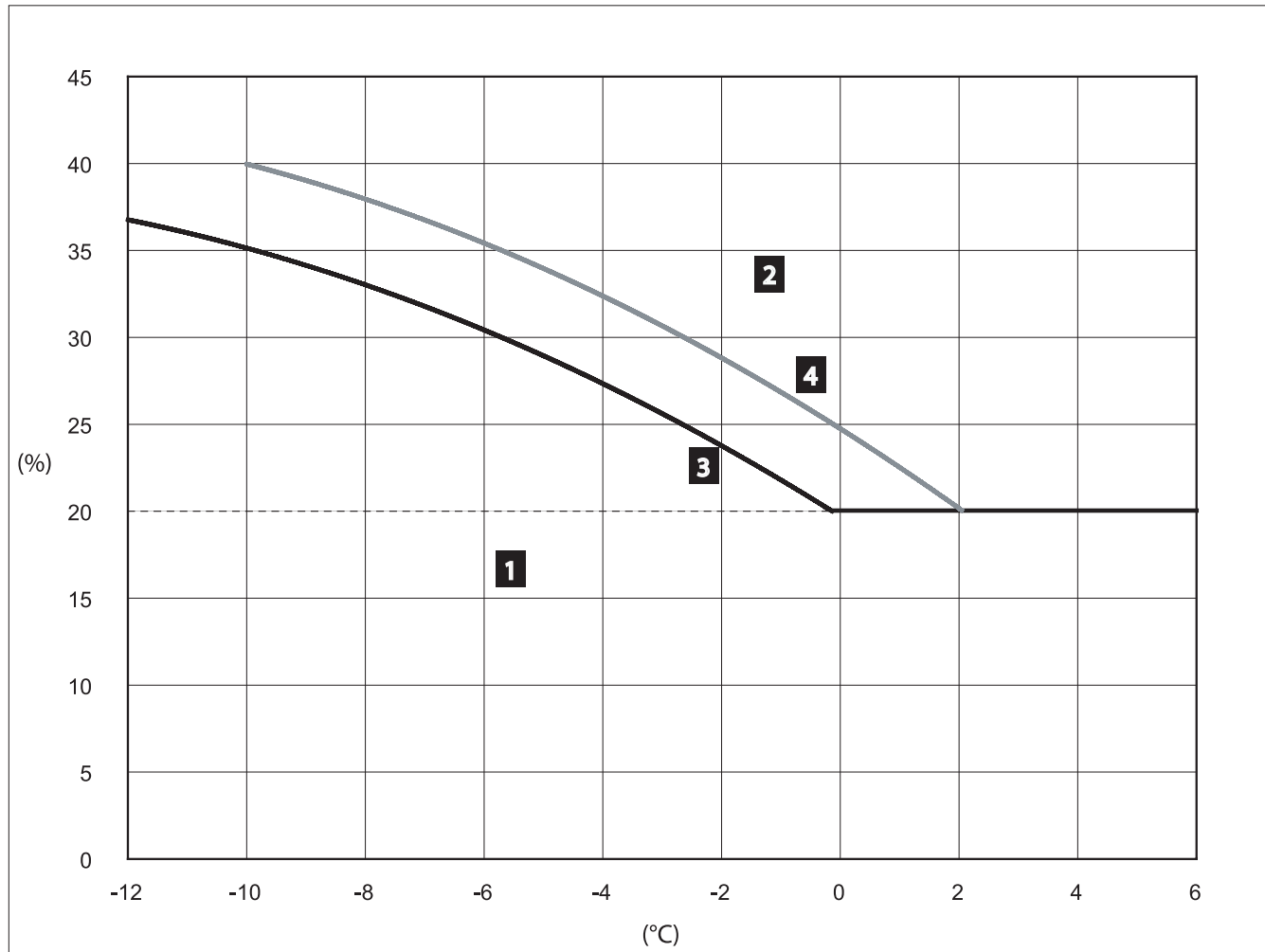

- 1 = Critical risks of freezing
- 2 = Efficient freeze protection
- 3 = Ethylene glycol
- 4 = Propylene glycol
- % = Glycol percentage (mass concentration)
- °C = Glycol or water temperature

CAUTION!

1. Additional glycol beyond the recommendations will adversely affect unit performance. The unit efficiency will be reduced and the saturated evaporator temperature will be reduced. For some operating conditions this effect can be significant.
2. If additional glycol is used, then use the actual % glycol to establish the low refrigerant cutout set point with Trane service advice.
3. The minimum low refrigerant cutout set point allowed is -20.6°C. This minimum is established by the solubility limits of the oil in the refrigerant.
4. With glycol application, ensure that there is no fluctuation of brine flow versus Order Write Up value, as a reduction of flow will adversely affect unit performance and behavior.
5. Full unit simulation is required for proper prediction of unit performance for specific operating conditions. For information on specific conditions, contact Trane.



General Electrical Recommendations

Electrical Parts

When reviewing this manual keep in mind.

- All field-installed wiring must be in accordance with local regulations, CE directives and guidelines. Be sure to satisfy proper equipment grounding requirements according CE
- The following standardized values - Maximum Amps - Short Circuit Amps - Starting Amps are displayed on unit nameplate.
- All field-installed wiring must be checked for proper terminations, and for possible shorts or grounds.

Note: Always refer to wiring diagrams shipped with chiller or unit submittal for specific electrical schematic and connection information.

Important: To prevent control malfunctions, do not run low voltage wiring (<30V) in conduit with conductors carrying more than 30 volts.

WARNING! Hazardous Voltage with Capacitor! Disconnect all electric power, including remote disconnects and discharge all motor start/run and AFD (Adaptive Frequency™ Drive) capacitors before servicing. Follow proper lockout/tagout procedures to ensure the power cannot be inadvertently energized.

- For variable frequency drives or other energy storing components provided by Trane or others, refer to the appropriate manufacturer’s literature for allowable waiting periods for discharges capacitors. Verify with an appropriate voltmeter that all capacitors have discharged
- DC bus capacitors retain hazardous voltages after input power has been disconnected. Follow proper lockout/tagout procedures to ensure the power cannot be inadvertently energized
- After disconnecting input power, wait five (5) minutes for units which are equipped with EC fans and wait twenty (20) minutes for units which are equipped with Variable frequency drive (0V DC) or with Power Factor correction option before touching any internal components.
- Failure to follow these instructions could result death or serious injury

Drive (AFD3) Capacitor Discharge” and BAS-SVX19B-E4.

Hazardous Voltage – Pressurized Burning Fluid!

Before removing compressor terminal box cover for servicing, or servicing power side of control panel, CLOSE COMPRESSOR DISCHARGE SERVICE VALVE and disconnect all electric power including remote disconnects. Discharge all motor start/run capacitors. Follow lockout/tagout procedures to ensure the power cannot be inadvertently energized. Verify with an appropriate voltmeter that all capacitors have discharged.

The compressor contains hot, pressurized refrigerant. Motor terminals act as a seal against this refrigerant. Care should be taken when servicing NOT to damage or loosen motor terminals.

Do not operate compressor without terminal box cover in place.

Failure to follow all electrical safety precautions could result in death or seriously injure.

CAUTION! To avoid corrosion, overheating or general damage, at terminal connections, unit is designed for copper mono-conductors only. In case of multiconductor cable, an intermediate connection box must be added. For cable with alternative material, bi-material connecting devices are mandatory. Cable routing inside control panel should be made case by case by installer.

Do not allow conduit to interfere with other components, structural members or equipment. Control voltage (115V) wiring in conduit must be separate from conduit carrying low voltage (<30V) wiring. To prevent control malfunctions, do not run low voltage wiring (<30V) in conduit with conductors carrying more than 30V.

WARNING! The Warning Label is displayed on the equipment and shown on wiring diagrams and schematics. Strict adherence to these warnings must be observed. Failure to do so may result in personal injury or death.

CAUTION! Units must not be linked to the neutral wiring of the installation. Units are compatible with the following neutral operating conditions:

TNS	IT	TNC	TT
Standard	Standard**	Special	Standard*

* Differential protection should be suited for industrial machinery with current leak which can be higher than 500 mA (several motors and frequency drives).

** Filter RFI disconnect on VPF and EC fan.

For additional information regarding the safe discharge of capacitors, see “Adaptive Frequency™



General Electrical Recommendations

Electrical Data

To get the following electrical data details: Refer to General Data tables for each unit configuration and size.

- Maximum Power input (kW)
- Unit rated amps (Max comp + Fan + Control)
- Unit start up amps (Starting Amps of the largest comp + RLA of 2nd comp + RLA of all fans+ control)
- Compressor Power factor
- Disconnect switch size (A)
- Short Circuit Rating for all sizes =15 kA

Wiring diagrams are shipped with unit and can be found in the unit control panel.

Note: Rating is made for 400 V, 3 phases, 50 Hz power supply.



Installer-Supplied Components

Customer wiring interface connections are shown in the electrical schematics and connection diagrams that are shipped with the unit. The installer must provide the following components if not ordered with the unit:

- Power supply wiring (in conduit) for all field-wired connections
- All control (interconnecting) wiring (in conduit) for field supplied devices
- Fused-disconnect switches

Power Supply Wiring

All power supply wiring must be sized and selected accordingly by the project engineer in accordance with standard IEC 60364. All wiring must comply with local codes. The installing (or electrical) contractor must provide and install the system interconnecting wiring, as well as the power supply wiring. It must be properly sized and equipped with the appropriate fuse-disconnect switches. The type and installation location(s) of the fused-disconnect switches must comply with all applicable codes.

Cut holes into the sides of the control panel for the appropriately-sized power wiring conduits. The wiring is passed through these conduits and connected to the terminal blocks.

To provide proper phasing of 3 phase input, make connections as shown in field wiring diagrams and as stated on the yellow WARNING label in the starter panel. Proper equipment grounds must be provided to each ground connection in the panel.

CAUTION! Customer wiring interface connections are shown in the electrical schematics and connection diagrams that are shipped with the unit. The installer must provide the following components if not ordered with the unit.

WARNING! To prevent injury or death, disconnect all electrical power sources before completing wiring connections to the unit.

CAUTION! The use of copper mono-conductors is the preferred solution to avoid corrosion and overheating at terminal connections.

Control Power Supply

Chiller is provided with control power transformer, it is not necessary to provide additional control power voltage to the unit.

Heater Power Supply

The evaporator shell is insulated from ambient air and protected from freezing for temperature down to -20°C by two thermostatically-controlled immersion heaters combined with evaporator pumps activation through Tracer™ UC800/Symbio800. Whenever the ambient temperature drops below 0°C the thermostat energizes the

heaters and the Tracer™ UC800/Symbio800 activates the pumps. If ambient temperatures below -20°C are expected, contact your Trane local office.

CAUTION! The control panel main processor does not check for loss of power to the heat tape nor does it verify thermostat operation. A qualified technician must frequently verify power to the heat tape and confirm operation of the heat tape thermostat, to avoid catastrophic damage to the evaporator.

CAUTION! With factory-fitted disconnect switch, trace heating is taken from the live side of the isolator, so power remains on. Supply voltage to the heating tapes is 400V.

Don't energize heaters without water. In case of winter water drainage for freeze protection, it is compulsory to disconnect the evaporator heaters to protect them from burning due to overheat.

Water Pump Power Supply

Provide power-supply wiring with fused disconnect switch(es) for the chilled water pump(s).

Interconnecting Wiring

Chilled Water Flow (Pump) Interlock

CGAF/CXAF requires a field-supplied, control-voltage contact input through a flow proving switch (6S51) and an auxiliary contact (6K51). Connect the proving switch and auxiliary contact to terminal 2 connector J2 cards (1A11). Refer to the field wiring diagram for details.

Chilled Water Pump Control

An evaporator water-pump output relay closes when the chiller is given a signal to go into the AUTO mode of operation from any source. The contact is opened to turn off the pump in the event of most machine-level diagnostics, to prevent the buildup of pump heat.

CAUTION! The evaporator water pump output relay must be used to control the chilled water pump and to benefit from the water pump timer function at startup and shutdown of the chiller. This is required when the chiller is in operation under freezing conditions, especially if the chilled water loop does not contain glycol.

CAUTION! Refer to Freeze Protection section for information about the evaporator circulating pump.

Alarm and Status Relay Outputs (Programmable Relays)

See CGAF / CXAF **User Guide** for alarm and status relay outputs.

EDLS and ECWS Analog Input Signal Wiring Details

See CGAF / CXAF **User Guide** for EDLS and ECWS.

Operating Principles

This section contains an overview of the operation of CGAF / CXAF air-cooled liquid chiller / Heat Pump equipped with microcomputer-based control systems. It describes the overall operating principles of the CGAF chiller / CXAF Heat Pump.

Note: To ensure proper diagnosis and repair, contact a qualified service organization if a problem could occur.

General

The Model CGAF / CXAF units are scroll compressor(s), dual circuit, air-cooled liquid chillers. These units are equipped with unit-mounted starter/control panels and operate with R454B or R410A refrigerant.

The basic components of a CGAF / CXAF unit are:

- Unit-mounted panel containing starter and Tracer™ UC800/Symbio800 controller and Input/Output LLIDS
- Scroll compressors
- Brazed plate / Shell & Tube evaporator
- Air-cooled MCHE / Fin & tube condenser with sub cooler
- Electronic Expansion Valve (EEXV)
- Related interconnecting piping

Refrigerant Cycle

The refrigeration cycle of the Model CGAF chiller / CXAF Heat Pump is conceptually similar to other Trane air-cooled chiller products. The CGAF chiller / CXAF Heat Pump uses a brazed plate / Shell & Tube evaporator and an air-cooled MCHE / Fin & tube condenser. The compressors use suction gas cooled motors and an oil management system to provide almost oil-free refrigerant to the condenser and evaporator for maximum heat transfer while lubricating and sealing compressor rotors and bearings. The lubrication system helps to assure long compressor life and contributes to quiet operation.

Refrigerant condenses in the MCHE / Fin & tube air-cooled heat exchanger. Liquid refrigerant is metered into the brazed plate or Shell and Tube evaporator using an electronic expansion valve to maximize chiller efficiency at full and part load operation.

The CGAF chiller / CXAF Heat Pump is equipped with a unit-mounted starter and control panel. Microprocessor based unit control modules (Trane Tracer™ UC800 /Symbio800) provide accurate chilled water control and providing monitoring,

protection and adaptive limit functions. The adaptive nature of the controls intelligently prevent the chiller from operating outside of its limits, or compensates for unusual operating conditions while keeping the chiller running rather than simply shutting off the chiller. If problems do occur, the Tracer™ UC800/Symbio800 controls provide diagnostic messages to help the operator in troubleshooting.

Oil System

The oil is efficiently separated inside the scroll compressor and will remain in the scroll compressor during all run cycles. Between 1-2% of the oil circulates around with the refrigerant.

See compressor section for oil level information.

Condenser and Fans

The air-cooled micro-channel condenser coils use all aluminium brazed fin construction and Fin & tube condenser coils use Copper tube and aluminium fin construction.

The MCHE coil is composed of three components: the flat micro channel tube, the fins located between the micro-channel tubes, and two refrigerant manifolds. Coils can be cleaned with high pressure water (see Condenser Coils maintenance for instructions).

Whereas Fin & Tube coil is composed of four components: the holding frame, Circular tube, U-bends joining the tube ends, the aluminium fins located above the tubes, and two refrigerant Headers. Coils can be cleaned with high pressure water (see Condenser Coils maintenance for instructions).

The condenser coils has an integral sub-cooling circuit. Condensers are factory proof and leak tested at 45 bars.

Direct-drive vertical-discharge airfoil condenser AC/EC fans are dynamically balanced.

Operating Principles

This section describes the overall flow chart principle for CGAF / CXAF. Detailed information for a given order is supplied with order package documentation.

Figure 9 – Example of Typical Refrigerant System Schematic & Oil Lube Circuit Schematic for CGAF - BPHE

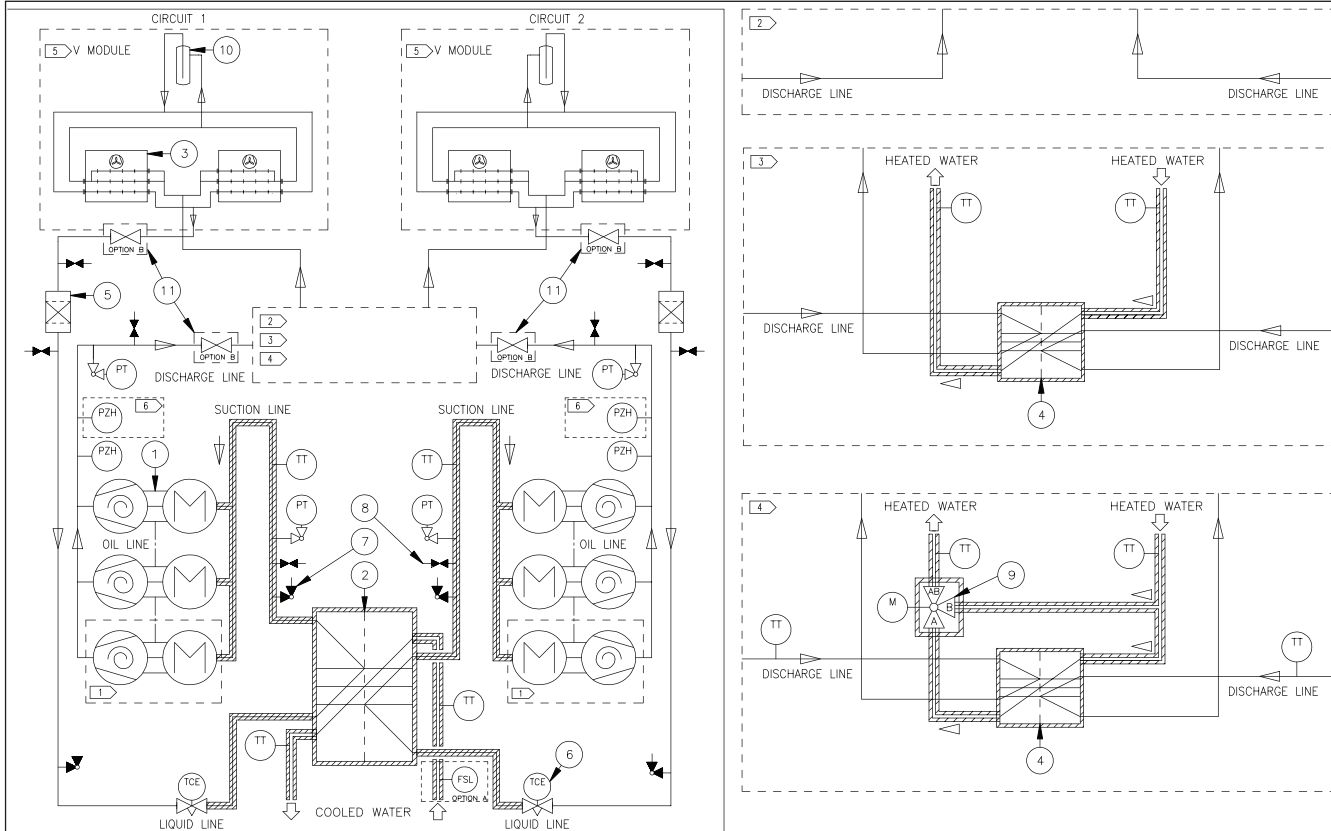

ITEM	DESIGNATION
1	SCROLL COMPRESSOR
2	EVAPORATOR (PLATE HEAT EXCHANGER)
3	CONDENSER (AIR COOLED EXCHANGER)
4	HEAT RECOVERY EXCHANGER (PLATE HEAT EXCHANGER)
5	FILTER DRIER
6	ELECTRIC EXPANSION VALVE
7	SERVICE VALVE
8	SCHRAEDER VALVE
9	3 WAY VALVE
10	RECEIVER
11	ISOLATION VALVE

ITEM	DESIGNATION
PT	PRESSURE TRANSDUCER
PZH	HIGH PRESSURE SWITCH
TT	TEMPERATURE SENSOR
TCE	ELECTRIC EXPANSION VALVE
FSL	EVAPORATOR WATER FLOW SWITCH
M	3 WAY VALVE MOTOR

—	REFRIGERANT LINE
---	OIL LINE
====	CHILLED / HEATED WATER LINE
	INSULATION

OPTION A : FLOW SWITCH FSL
 OPTION B : ISOLATION VALVE PER MANIFOLD COMPRESSOR

- 1 ONLY FOR CGAF 140-150-165-180-190
- 2 COOLING ONLY UNIT
- 3 PARTIAL HEAT RECOVERY OPTION
- 4 TOTAL HEAT RECOVERY OPTION
- 5 V MODULE DETAILS REFER TABLE BELOW
- 6 REQUIRED IF REFRIGERANT CHARGE >30kg/CIRCUIT (ONLY FOR R454B)

CGAF SIZES	080	090	100	110	130	140	150	165	180	190
V MODULE	SE	1V	1.5V	1.5V	1.5V	1.5V	2V	2V	2V	2.5V
PER CIRCUIT	HE/XE	1.5V	2V	2V	2V	2V	2.5V	2.5V	2.5V	3V

Operating Principles

Figure 10 – Example of Typical Refrigerant System Schematic & Oil Lube Circuit Schematic for CGAF S&T

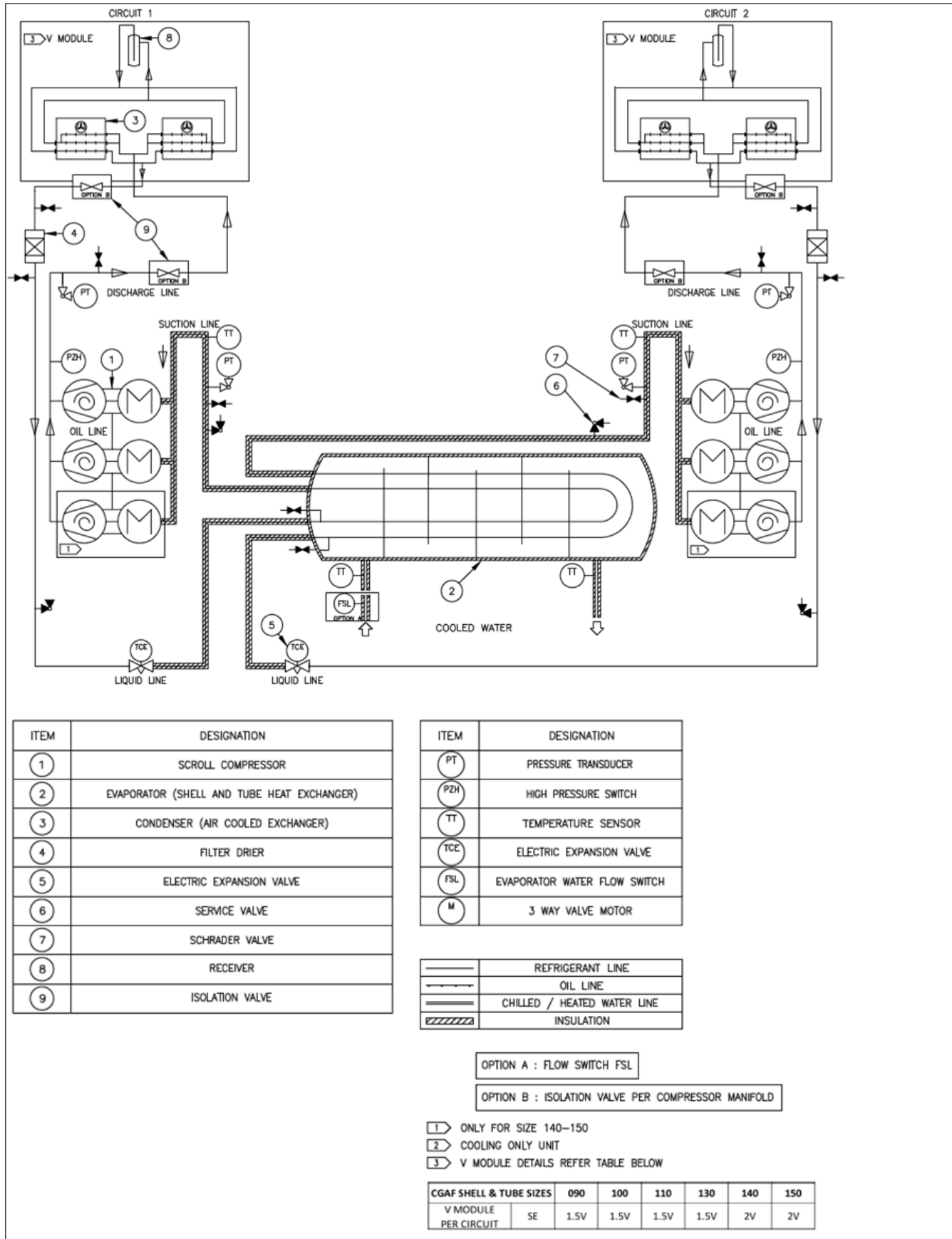

Operating Principles

Figure 11 – Example of Typical Refrigerant System Schematic & Oil Lube Circuit Schematic for CXAF - BPHE

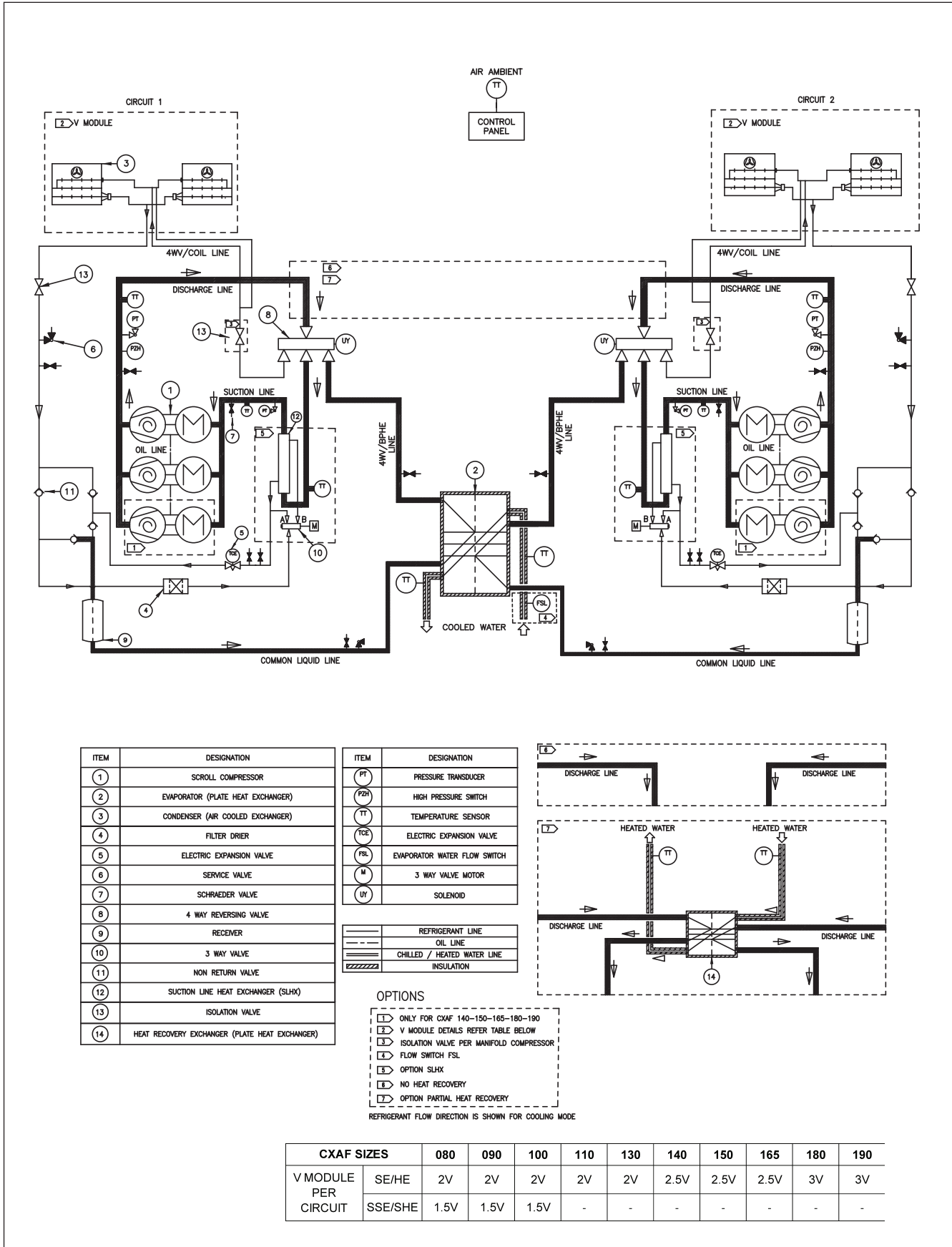

Operating Principles

Figure 12 – Example of Typical Refrigerant System Schematic & Oil Lube Circuit Schematic for CXAF Heat

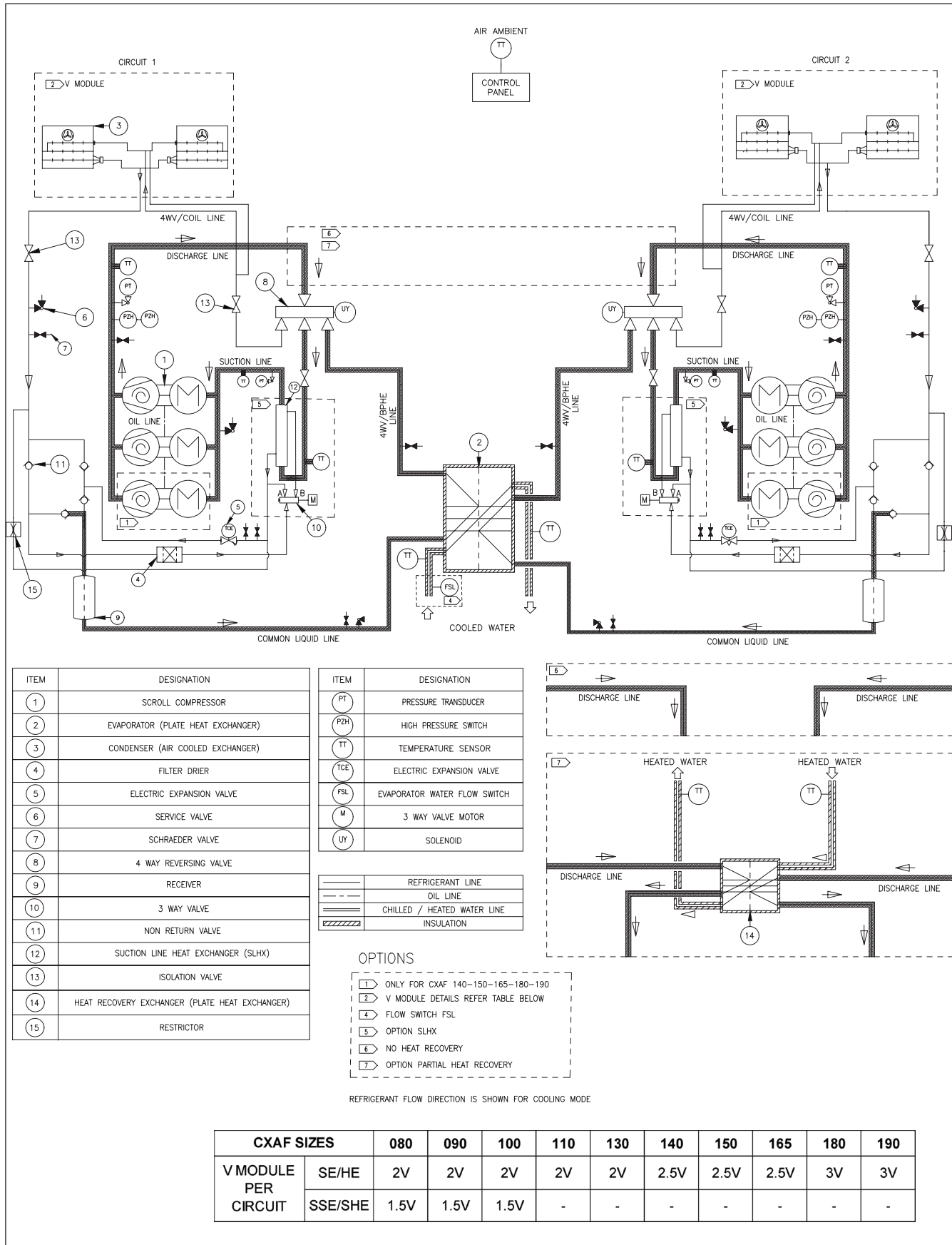

Operating Map

Figure 13 – Operating Map for CGAF / CXAF

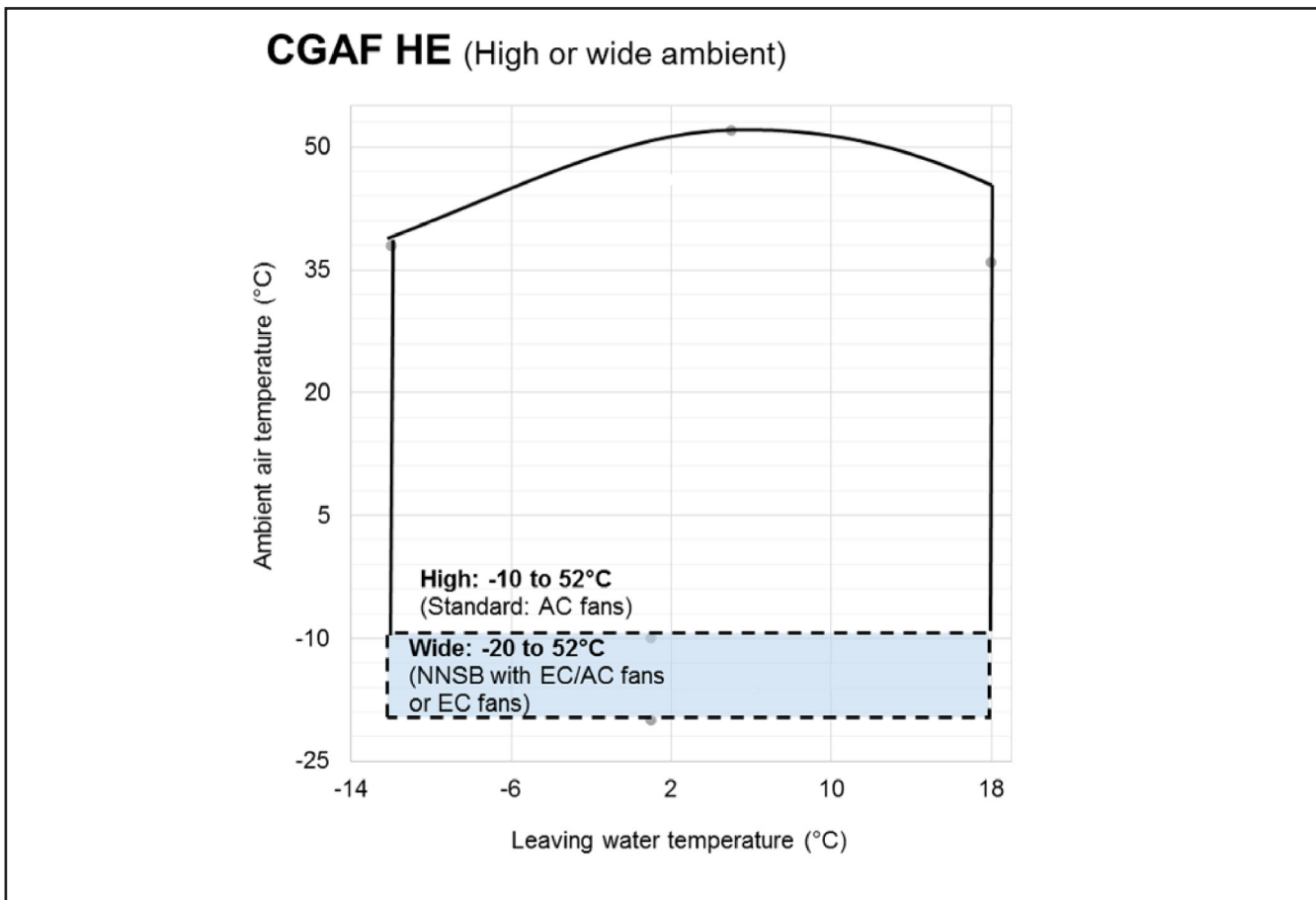
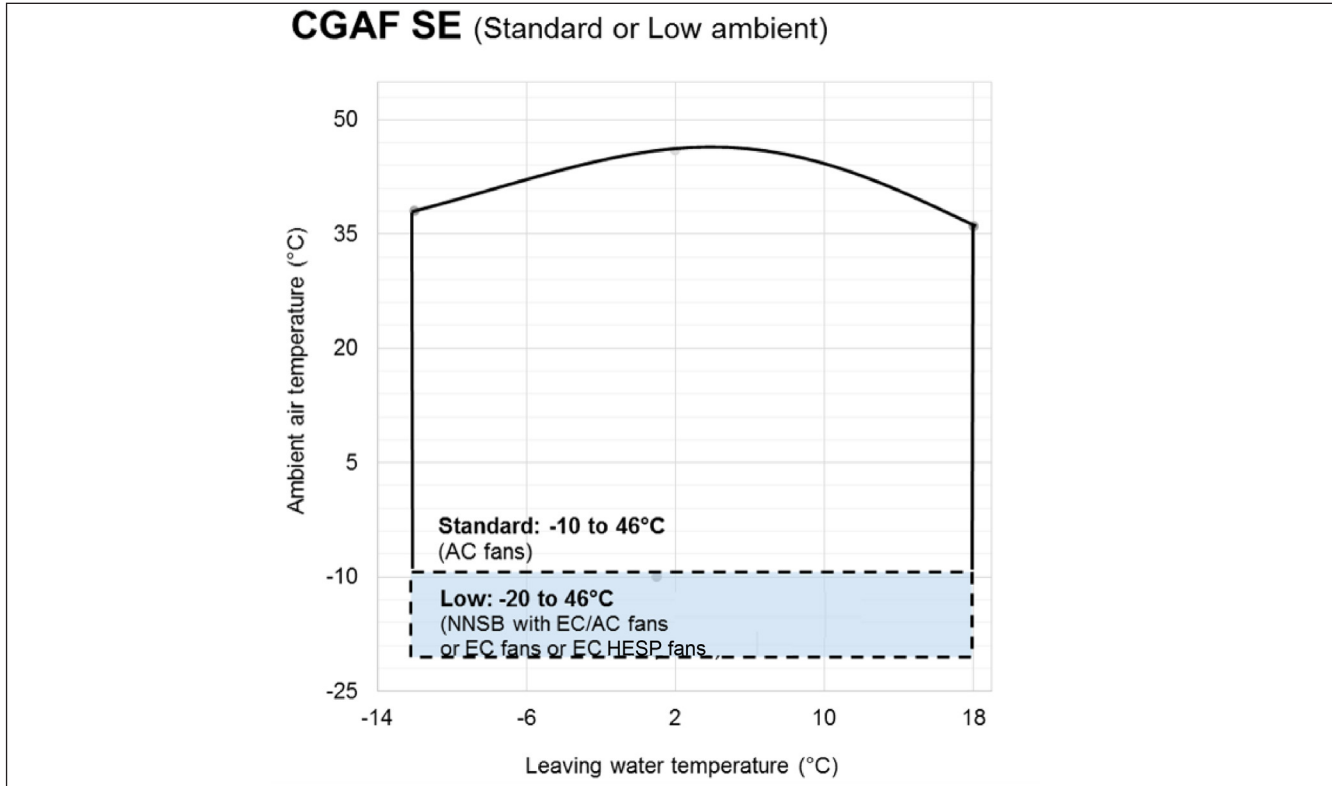

Operating Map

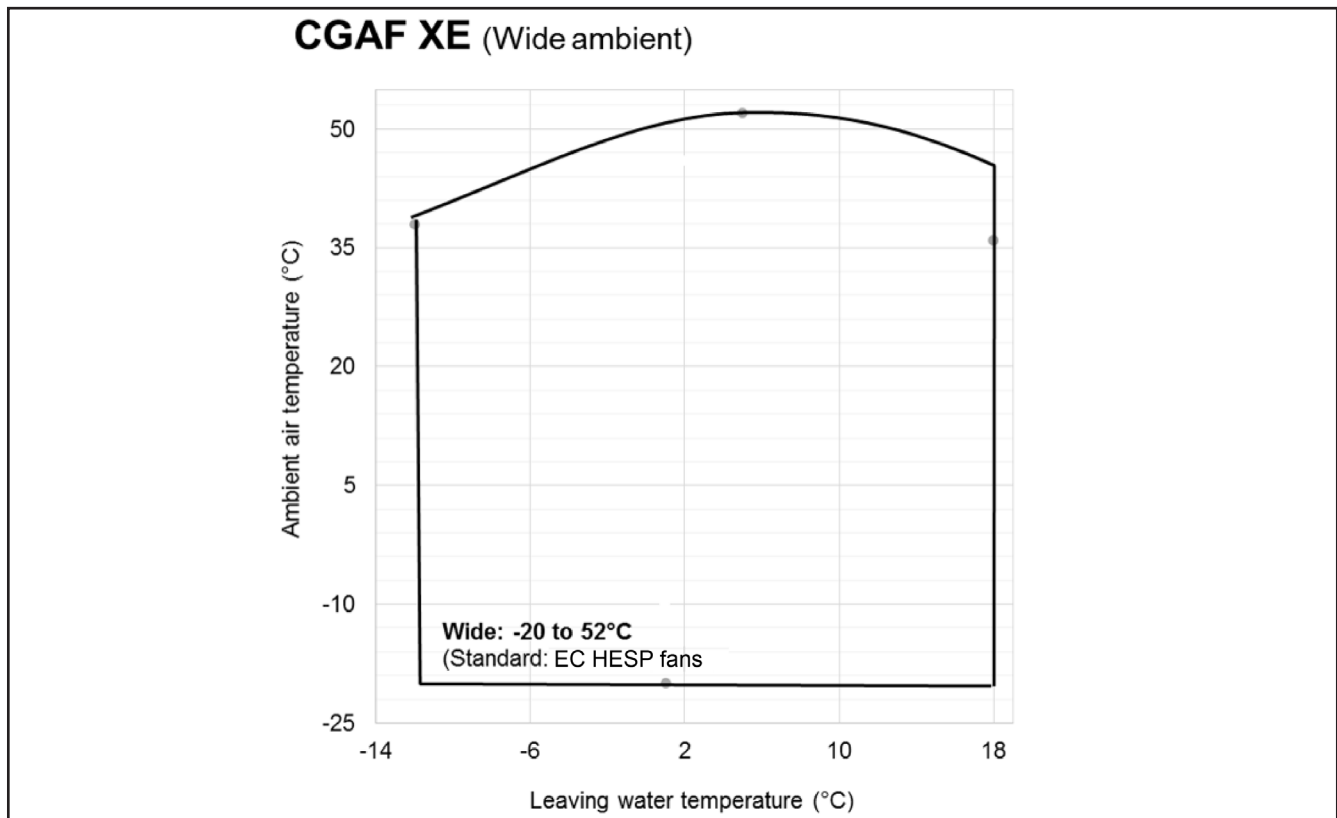

Operating Map

Figure 14 – CXAF Cooling Operating Map

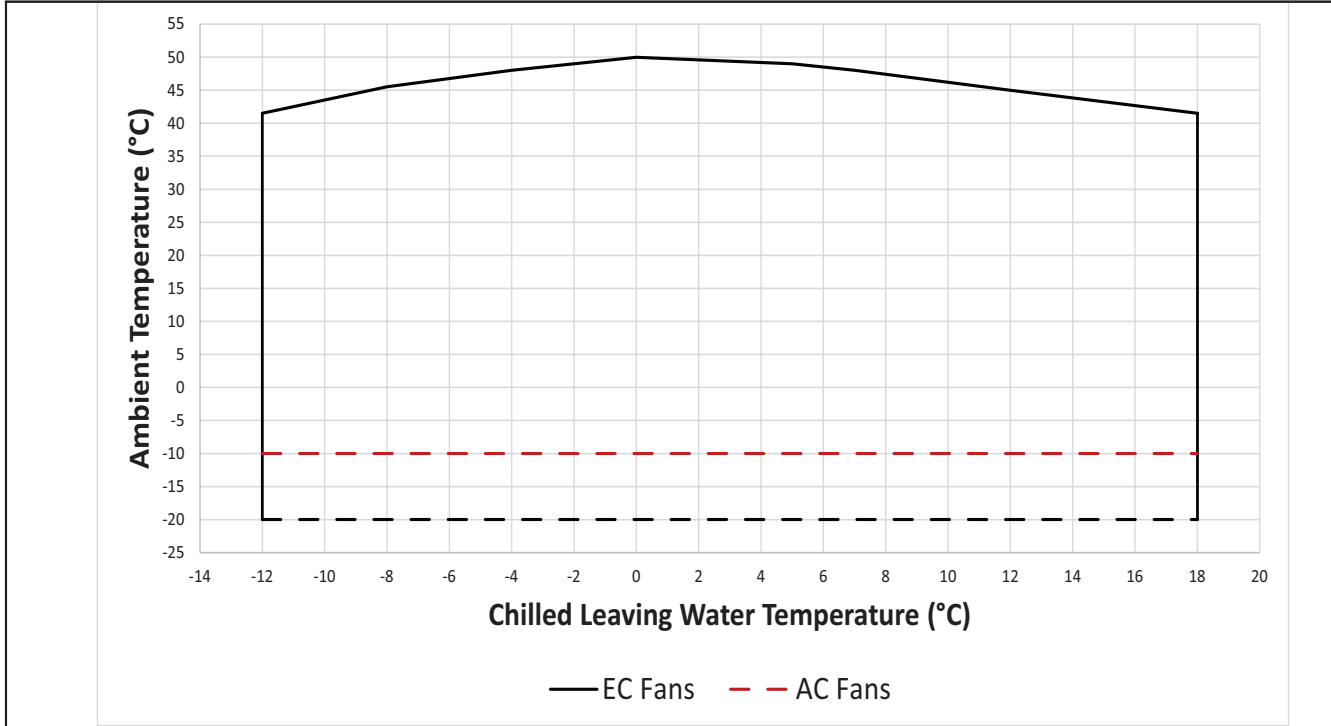
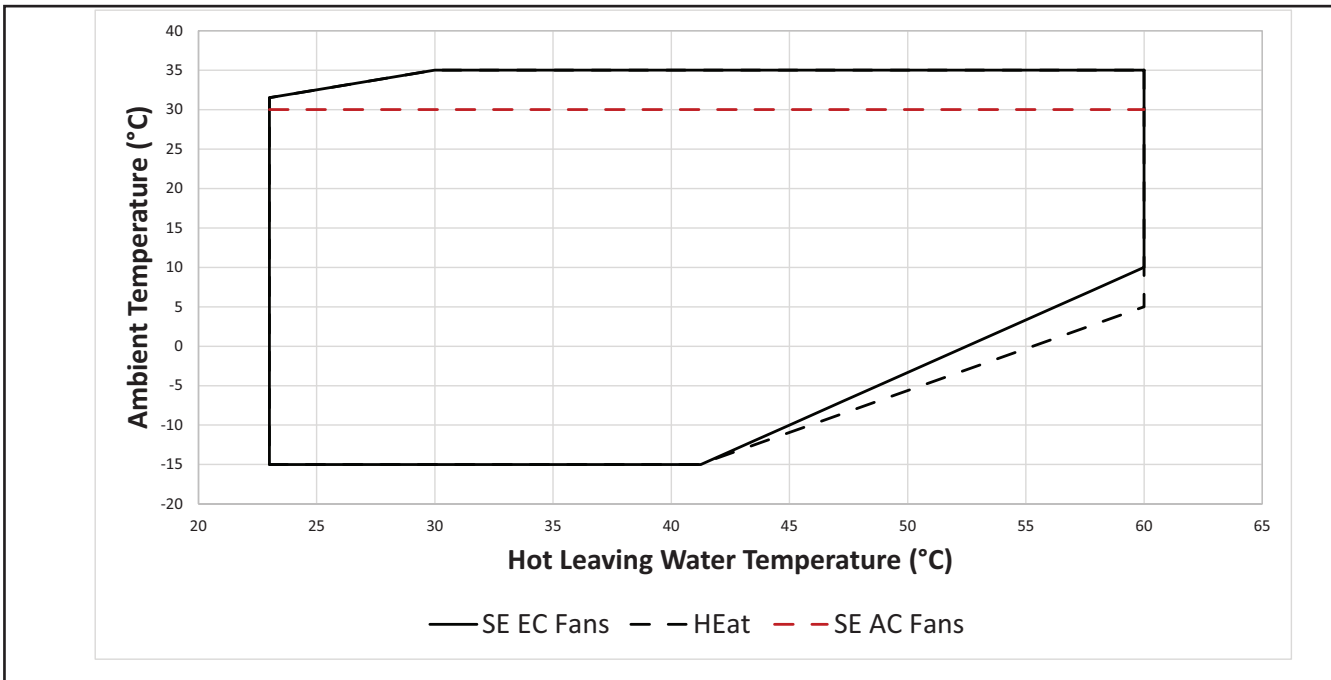

Figure 15 – CXAF Heat Pump Operating Map



Notes:

- (1) In cooling mode: chilled water flow defined by Cooling rating at 35°C outdoor air and water temperatures 12/7°C (EN14511:2018).
- (2) In heat pump mode: hot water flow defined by Heat Pump rating at 7(6)°C outdoor air and water temperatures 40/45°C (EN14511:2018).
- (3) Operation maps are made based on default factory control settings.



Total Heat Recovery

The total heat recovery option includes:

- A Common braze plate heat exchanger for both refrigeration circuits installed in serial between with the compressor discharge and air-cooled condenser, allowing mix of liquid and gas at the outlet leaving to condenser coil.
- MCHE Condenser coil with EC fan motor only to maintain the discharge pressure above the THR water outlet condensing temperature.
- A 3-way modulating valve factory installed on the water side to manage the leaving water temperature and required high discharge pressure.
- Two temperature sensors for inlet and outlet hot water temperature control.
- Freeze protection heaters (option).

The heat exchanger is used both as a desuperheater and a condenser of compressors discharge gas. Refrigerant leaves the total heat recovery braze plates heat exchanger as a mixture of gas and liquid. The air-cooled condenser is used to finalize the condensation and provide a subcooled refrigerant to the expansion valve.

Main stream of refrigerant flow in these units is through filter drier keeping bypass opening to 10% with THR Off. This avoid oil distillation in dead branch. During THR operation bypass valve open 100% allowing 65% of refrigerant flow via bypass line to maintain pressure.

The heating capacity is driven by the cooling demand on the chiller, the ambient temperature and the temperature of the heat recovery loop. The heating capacity is optimized by a smart control of the condensing temperature using the fans.

Water circulating inside the heat recovery heat exchanger should never be used in food processing or as drinking water. It must be used through a direct loop to heat or preheat water.

Note: Ambient temperature shall be lower than THR leaving water temperature set point to operate allowing 45% up to 116% evaporator heat recovery

Note: If the total heat recovery heat exchanger is drained, the heater must be turned off to avoid damaging the total heat recovery heat exchanger. The heater should only be on when the heat recovery heat exchanger has water in it.

CAUTION! Discharge gas temperature can reach 130°C, may resulting in overheating of the heat recovery water if there is no appropriate flow.

CAUTION! For the first start, Total Heat Recovery water temperature sensors should be checked to make sure that they are not reversed.

CAUTION! A field-installed safety or relief valve on the water side is required with the total heat recovery to prevent risks resulting from a failure of the unit control.

Piping Recommendations

A 1 to 1.6 mm strainer must be installed close to the total heat recovery heat exchanger entering water line to protect the heat exchanger.

Insulate water lines and other portions of the heat recovery water loop to prevent heat loss and potential injury due to exposure to a hot surface.

Do not use untreated or improperly treated water in the heat recovery water loop since it will cause inefficient operation and potential damage to the unit such as: reduced heat transfer between water and refrigerant, increased water pressure drop and reduced water flow.

CAUTION! : Proper Water Treatment! The use of untreated or improperly treated water in a chiller may result in scaling, erosion, corrosion, algae, or slime. It is recommended that the services of a qualified water treatment specialist be engaged to determine what water treatment, if any, is required. Trane assumes no responsibility for equipment failures which result from untreated or improperly treated water, or saline or brackish water.

Freeze Protection (Option)

The heat recovery condenser is insulated and a factory-installed heater is installed and will protect the heat exchanger from freezing in ambient temperatures down to -18°C. When the ambient temperature drops to approximately 5°C, the main controller energizes the heaters.

Note: The inlet and outlet piping should be protected against freezing by one of the following methods:

- Install heat tape on all field installed water piping.
- Add freeze inhibit fluid to the total heat recovery water loop.

Table 9 – General Data for Total Heat recovery (THR) Option CGAF 080-190

		CGAF 080	CGAF 090	CGAF 100	CGAF 110	CGAF 130	CGAF 140	CGAF 150	CGAF 165	CGAF 180	CGAF 190
Heat Exchanger Type		Stainless steel Copper Brazed plate Heat exchanger									
THR Heat Exchanger model		DB400 x74	DB400 x74	DB400 x90	DB400 x90	DB400 x90	DB400 x122	DB400 x122	DB400 x122	DB400 x150	DB400 x150
Water connection size	(in) - (mm)	3"OD - 76.1	3"OD - 76.1	3"OD - 76.1	3"OD - 76.1	3"OD - 76.1	3"OD - 76.1	3"OD - 76.1	3"OD - 76.1	3"OD - 76.1	3"OD - 76.1
Water content volume	L	15.2	15.2	18.5	18.5	18.5	25.3	25.3	25.3	31.2	31.2
Additional Shipping Weight	kg	155	155	165	165	165	210	210	210	245	265
Freeze protection – Electric heater											
Max Power input	(kW)	0.28	0.28	0.28	0.34	0.34	0.34	0.34	0.34	0.34	0.34
Max Amps	(A)	0.7	0.7	0.7	0.85	0.85	0.85	0.85	0.85	0.85	0.85

Total Heat Recovery

Figure 16 – Refrigerant Schematic THR option

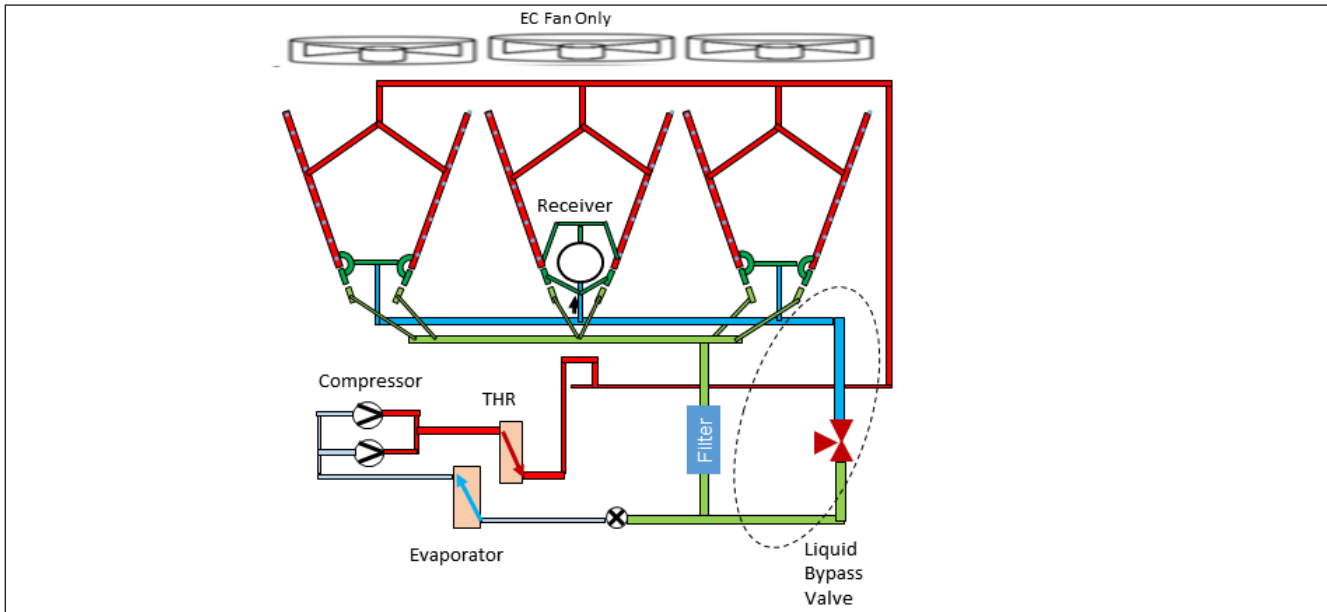

THR should not be used for glycol application on evaporator side. Minimum THR start-up water temperature should be higher than 5°C. THR should be used when leaving evaporator temperature is between 5 and 15.5°C.

Table 10 – Operating Map (THR) CGAF 080-190

Application	Standard ambient (°C)	High ambient (°C)
Min. outdoor air temperature	7.2	7.2
Max. outdoor air temperature	49	52
Min. leaving evaporator water temperature	4.4	4.4

Application	Standard ambient (°C)	High ambient (°C)
Max. leaving evaporator water temperature	15.6	15.6
Min. leaving THR water temperature	30	30
Max. leaving THR water temperature	55	55

THR 3-Way Valve Description

The 3-way valve is divided into 2 main parts: the actuator and the valve body.

Valve body

2 types of valve are used (DN50, DN65) with a Kvs respectively of 40, **.

Kvs –value is showing the capacity of media flow of a valve, it characterizes the volume flow (m³/h) of water by measuring a differential pressure (bar). This value is related to full stroke.

The 3-way valve body is connected to the system in 3 points A, B, AB as below:

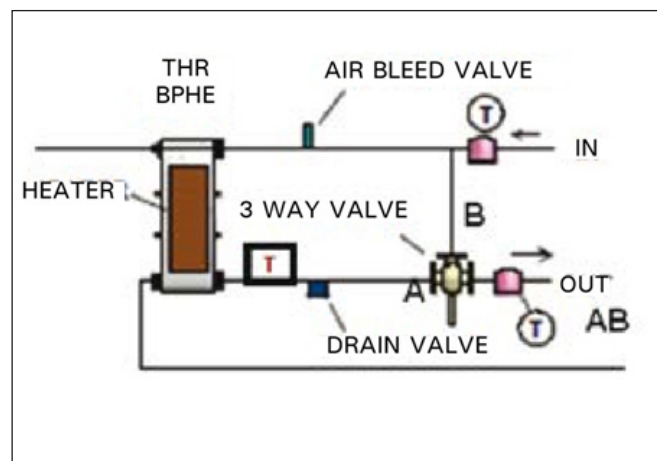

Total Heat Recovery

Figure 17 – Total Heat Recovery Operating Map

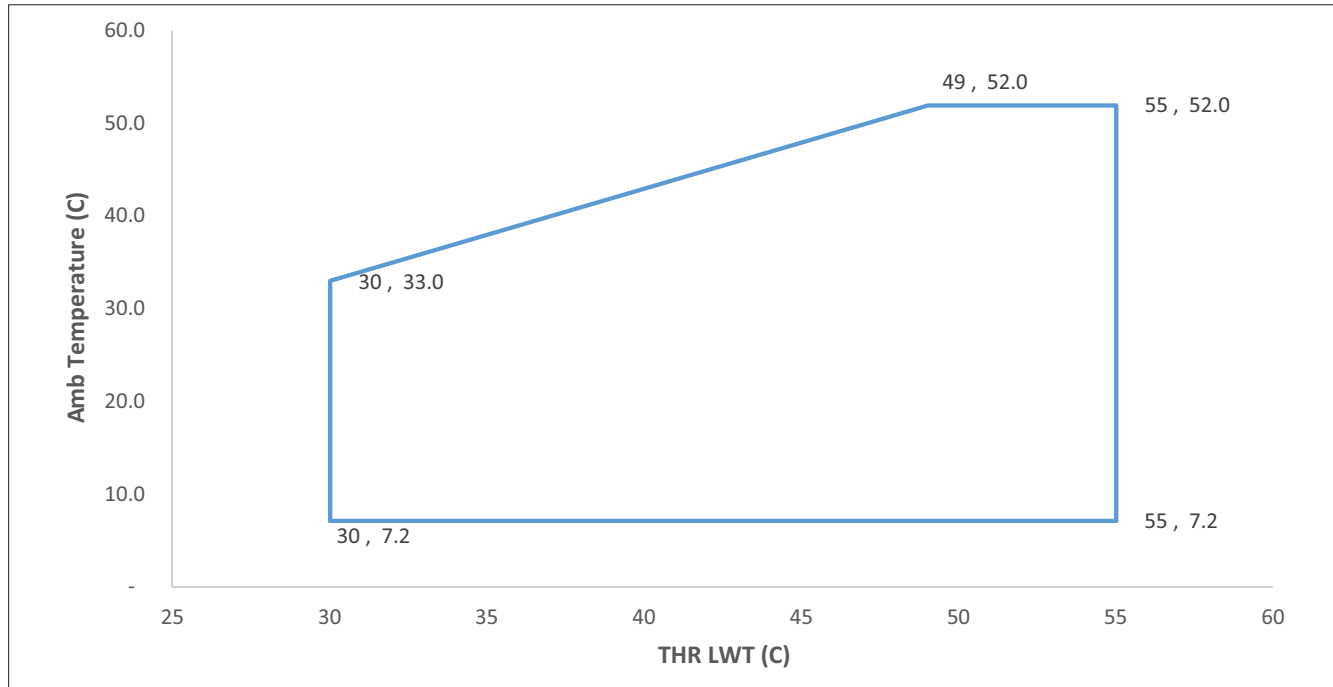

Actuator Overview

- Supply voltage: 24 Vac
- Actuator setting
 - W1(input signal failure): 100%, actuator will adjust to 100% position when signal input fails (THR BP bypassed)
 - W2(input signal range): LED "OFF" for 2~10V
 - W3 (direction of action): LED "ON" 2V for A-AB close, 10V for A-AB full ope

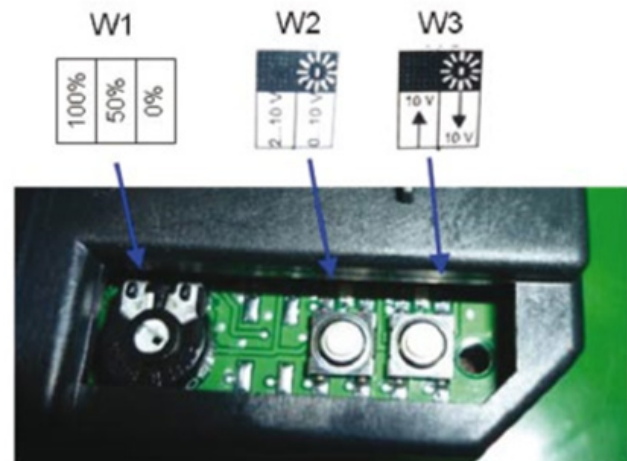

Refrigerant Charge

When a total heat recovery is installed, refrigerant charge (kg) are as shown in the table below.

Table 11 – Refrigerant Charge (THR Option) CGAF 080-190

		Refrigerant charge THR Option										
		80	90	100	110	130	140	150	165	180	190	
R410A	Base	SE		18	19	19.5	20.5	30	32	33	38	39
		HE/XE	22	27.5	27.5	28.5	29	39	39	39	43	43.5
	THR	SE		36	34	34	36	43	45	46	60	61
		HE/XE	36	40	41	41	42	61	61	61	63	64
R454B	Base	SE		15	16	16	17	25	26.5	27.5	31.5	32.5
		HE/XE	18.5	23	23	23.5	24	32.5	32.5	32.5	35.5	36
	THR	SE		30	28	28	30	35.5	37.5	38	50	50.5
		HE/XE	30	33	34	34	35	50.5	50.5	50.5	52.5	53

Total Heat Recovery

Figure 18 – Total heat recovery water loop pressure drop Total THR & BPHE (THR) Curve

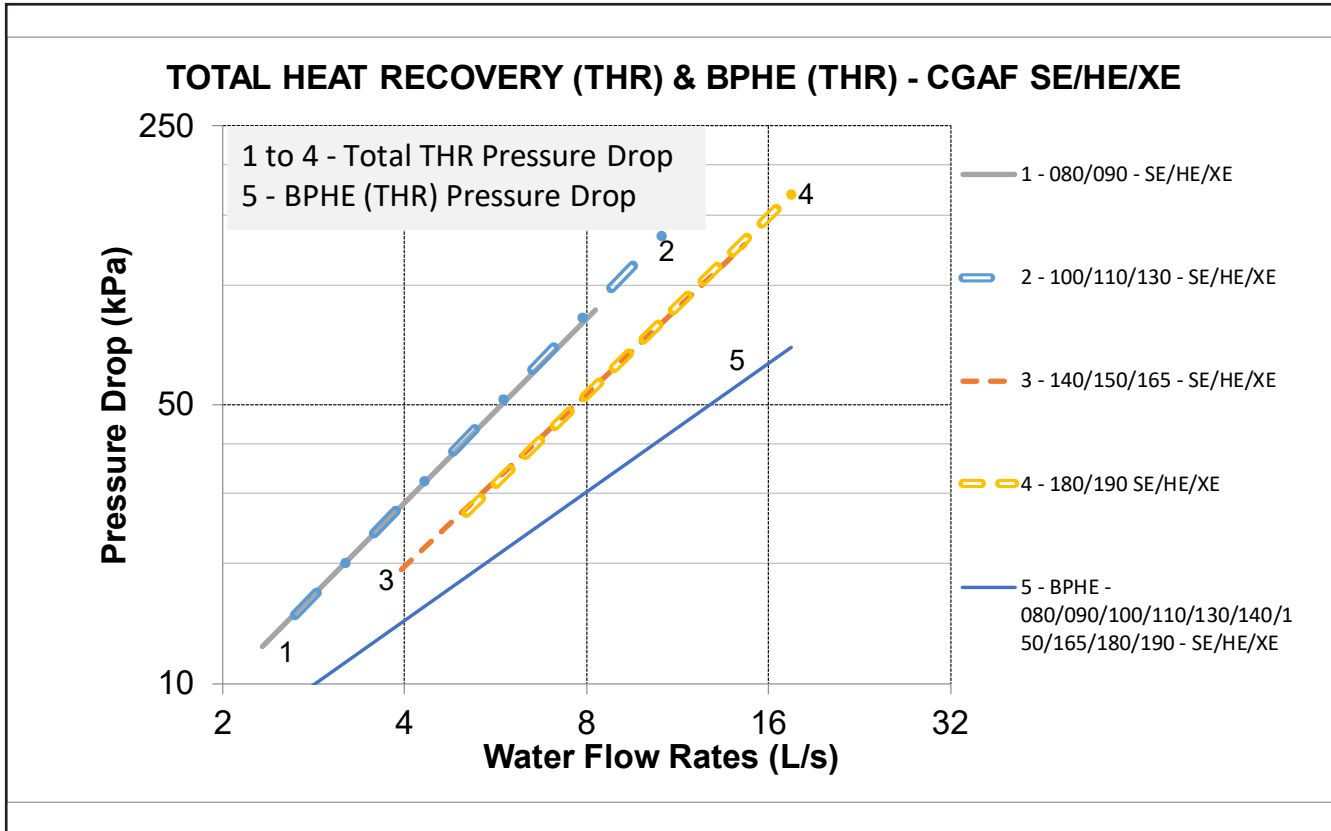
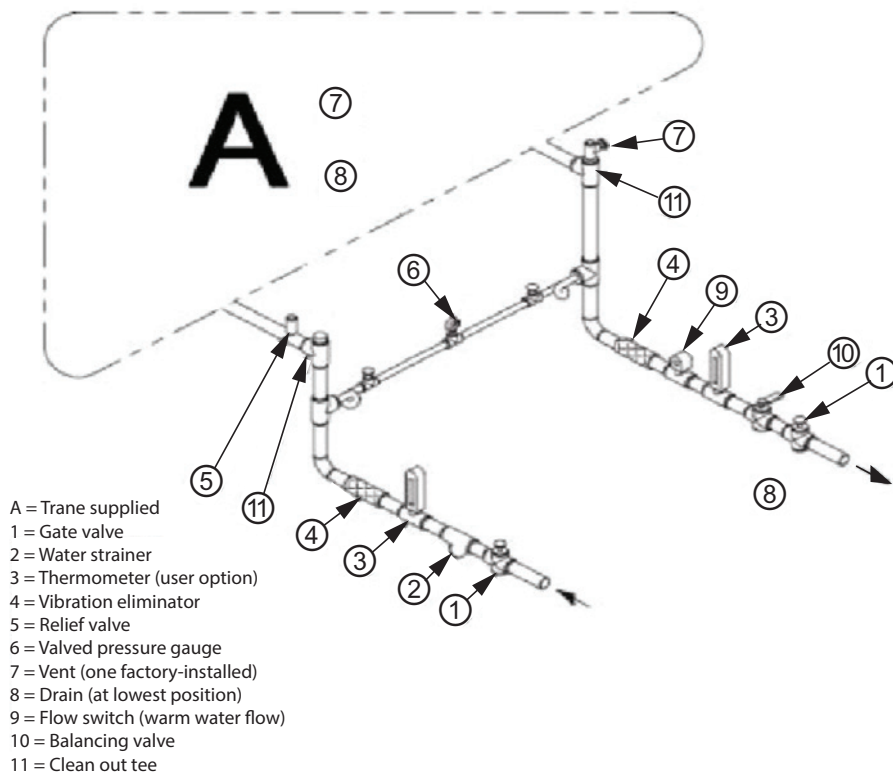

Figure 19 – Partial / Total heat recovery pipe recommendations



Partial Heat Recovery Option

Heat recovery option is made with a plate heat exchanger in series with the air-cooled condenser. This heat exchanger benefits the discharge gas superheat as well as a part of the condensing gas heat to be transferred to hot water system. The chiller can simultaneously produce chilled water and hot water.

The heating capacity is driven by the cooling demand on the chiller, the ambient temperature and the temperature of the heat recovery loop.

The partial heat recovery includes:

- One common brazed plate heat exchanger for both refrigerant circuit.
- Two temperature sensors to read the inlet/outlet hot water temperature information on the unit control display.
- Freeze protection heater (option).

Note: Unit can recover only the compressor power input in Partial heat recovery mode.

Water circulating inside the heat recovery heat exchanger should never be used for food process or drinking water. It must be used through a direct loop to heat or preheat water.

Note: If the partial heat recovery heat exchanger is drained, the heater must be turned off to avoid damaging the partial heat recovery heat exchanger. The heater should only be on when the heat recovery heat exchanger has water in it.

CAUTION! Discharge gas temperature can reach 130°C, may resulting in overheating of the heat recovery water if there is no appropriate flow.

Partial Heat Recovery Piping

A field-installed safety or relief valve on the water side is required with the partial heat recovery to prevent risks resulting from a failure of the thermostat.

A 1 to 1.6 mm strainer must be installed close to the partial heat recovery heat exchanger entering water line to protect the heat exchanger.

The partial heat recovery water temperature entering the unit should be at least 40°C.

Insulate water lines and other portions of the heat recovery water loop to prevent heat loss and potential injury due to exposure to a hot surface.

For recommended partial heat recovery piping, see figure.

Do not use untreated or improperly treated water in the heat recovery water loop since it will cause inefficient operation and potential damage to the unit such as: reduced heat transfer between water and refrigerant, increased water pressure drop and reduced water flow.

CAUTION!: Proper Water Treatment! The use of untreated or improperly treated water in a chiller may result in scaling, erosion, corrosion, algae, or slime. It is recommended that the services of a qualified water treatment specialist be engaged to determine what water treatment, if any, is required.

Note: Trane assumes no responsibility for equipment failures which result from untreated or improperly treated water, or saline or brackish water.

Partial Heat Recovery Freeze Protection (option)

The heat recovery condenser is insulated and a factory-installed heater is installed and will protect the heat exchanger from freezing in ambient temperatures down to -18°C. When the ambient temperature drops to approximately 5°C, the main controller energizes the heaters.

Note: The inlet and outlet piping should be protected against freezing by one of the following methods:

- Install heat tape on all field installed water piping
- Add freeze inhibit fluid to the partial heat recovery water loop.

Partial Heat Recovery Option

Figure 20 – Water pressure drop - heat recovery heat exchanger

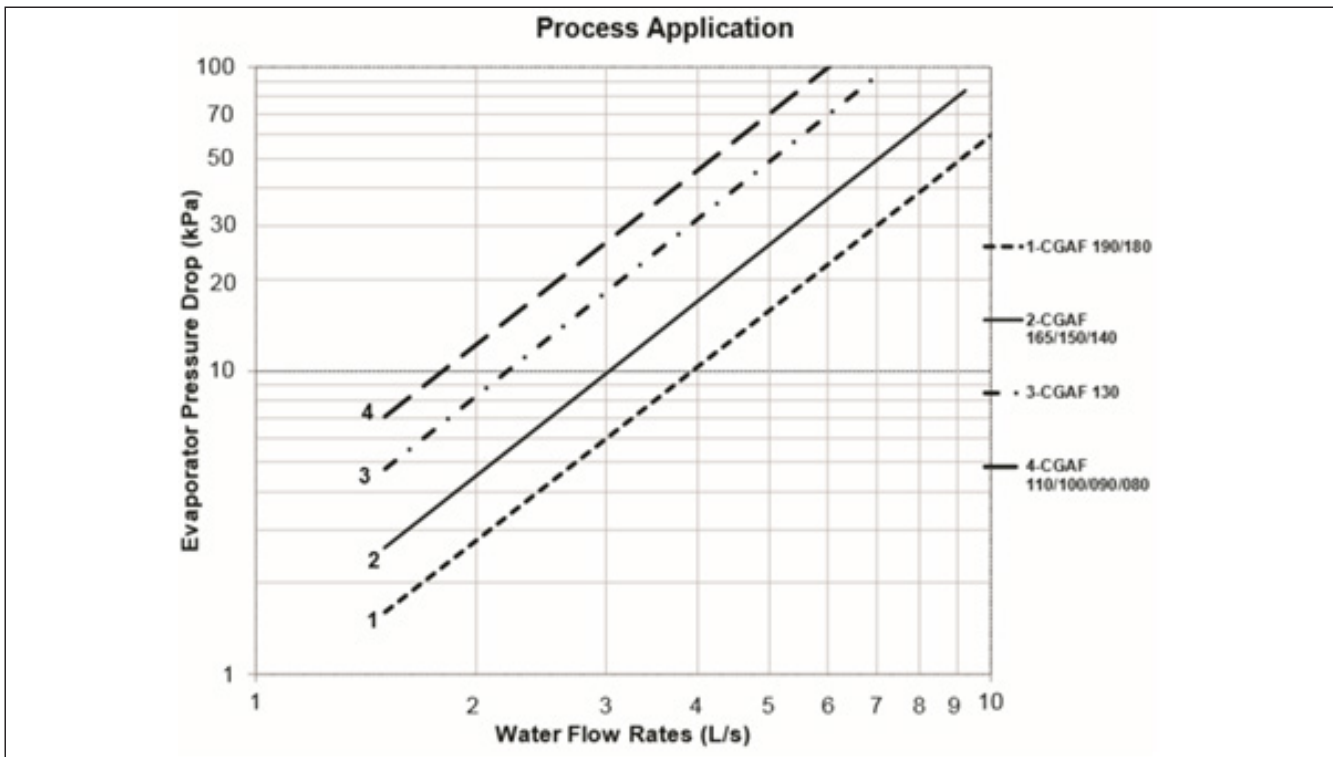
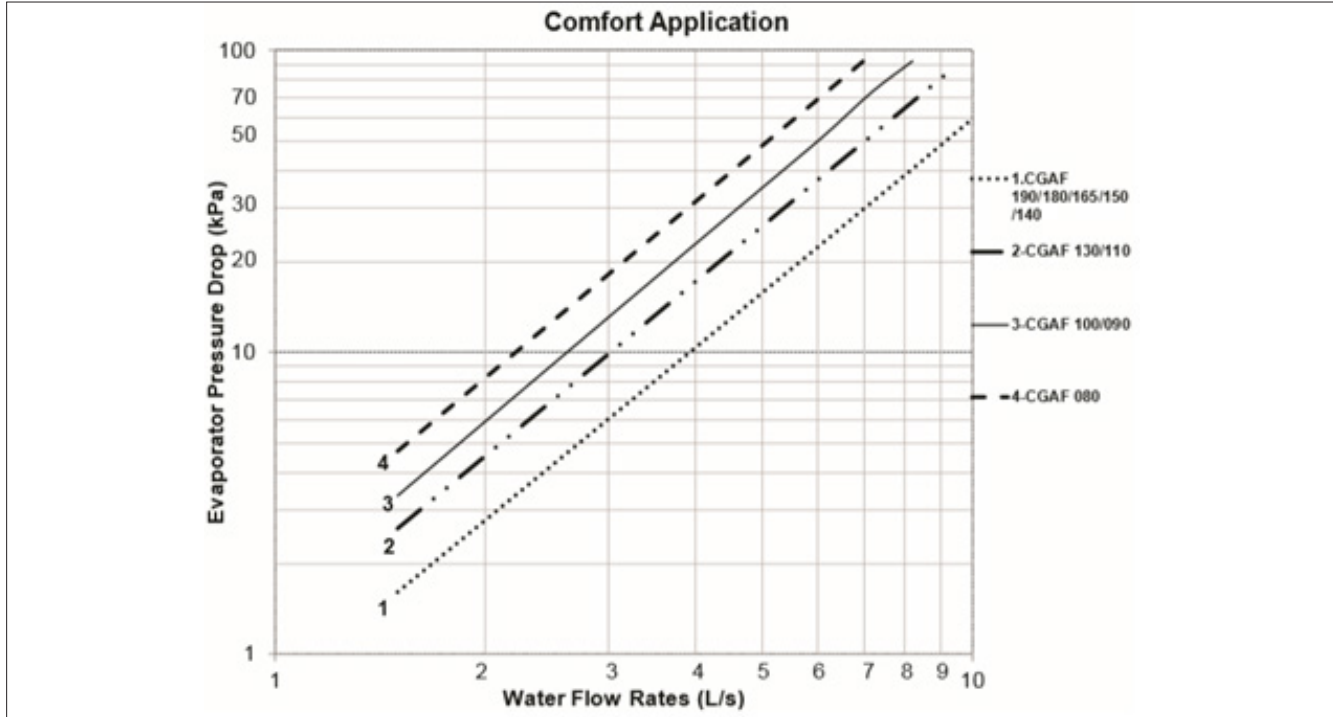



Partial Heat Recovery Option

Table 12 – General Data for Partial Heat recovery CGAF 090-190 Standard Efficiency

	CGAF 90 SE	CGAF 100 SE	CGAF 110 SE	CGAF 130 SE	CGAF 140 SE	CGAF 150 SE	CGAF 165 SE	CGAF 180 SE	CGAF 190 SE
Partial Heat recovery (PHR) option									
Heat-Exchanger Type	Stainless steel Copper Brazed plate Heat exchanger								
Digit 19=N or C									
Heat-Exchanger Model	B12MT/ D-80	B12MT/ D-80	B35TM4/ D-48	B35TM4/ D-48	B35TM4/ D-64	B35TM4/ D-64	B35TM4/ D-64	B35TM4/ D-64	B35TM4/ D-64
Water connection size (Thread connection)	(in) - (mm) 2" - 60.3	2" - 60.3	2" - 60.3	2" - 60.3	2 1/2" - 76.1	2 1/2" - 76.1	2 1/2" - 76.1	2 1/2" - 76.1	2 1/2" - 76.1
Water content volume	(l) 2.40	2.40	4.32	4.32	5.76	5.76	5.76	5.76	5.76
Digit 19=P									
Heat-Exchanger Model	B12MT/ D-48	B12MT/ D-48	B12MT/ D-48	B12MT/ D-60	B35TM4/ D-64	B35TM4/ D-64	B35TM4/ D-64	B35TM4/ D-64	B35TM4/ D-64
Water connection size (Thread connection)	(in) - (mm) 1 1/2" - 48.3	1 1/2" - 48.3	1 1/2" - 48.3	2" - 60.3	2" - 60.3	2" - 60.3	2" - 60.3	2 1/2" - 76.1	2 1/2" - 76.1
Water content volume	(l) 1.44	1.44	1.44	1.80	4.32	4.32	4.32	4.32	4.32
Antifreeze Heater Max Power Input (Standard Digit 19=N or C / Process Digit 19=P)	(W) 60 / 60	60 / 60	120 / 60	120 / 60	120 / 120	120 / 120	120 / 120	120 / 120	120 / 120
Antifreeze Heater Max Amps (Standard Digit 19=N or C / Process Digit 19=P)	(A) 0.15 / 0.15	0.15 / 0.15	0.3 / 0.15	0.3 / 0.15	0.3 / 0.3	0.3 / 0.3	0.3 / 0.3	0.3 / 0.3	0.3 / 0.3

Table 13 – General Data for Partial Heat recovery CGAF 080-190 High Efficiency

	CGAF 80 HE	CGAF 90 HE	CGAF 100 HE	CGAF 110 HE	CGAF 130 HE	CGAF 140 HE	CGAF 150 HE	CGAF 165 HE	CGAF 180 HE	CGAF 190 HE
Partial Heat recovery (PHR) option										
Heat-Exchanger Type	Stainless steel Copper Brazed plate Heat exchanger									
Digit 19=N or C										
Heat-Exchanger Model	B12MT/ D-60	B12MT/ D-80	B12MT/ D-80	B35TM4/ D-48	B35TM4/ D-48	B35TM4/ D-64	B35TM4/ D-64	B35TM4/ D-64	B35TM4/ D-64	B35TM4/ D-64
Water connection size (Thread connection)	(in) - (mm) 1 1/2" - 48.3	2" - 60.3	2" - 60.3	2" - 60.3	2" - 60.3	2 1/2" - 76.1	2 1/2" - 76.1	2 1/2" - 76.1	2 1/2" - 76.1	2 1/2" - 76.1
Water content volume	(l) 1.80	2.40	2.40	4.32	4.32	5.76	5.76	5.76	5.76	5.76
Digit 19=P										
Heat-Exchanger Model	B12MT/ D-48	B12MT/ D-48	B12MT/ D-48	B12MT/ D-48	B12MT/ D-60	B35TM4/ D-48	B35TM4/ D-48	B35TM4/ D-48	B35TM4/ D-64	B35TM4/ D-64
Water connection size (Thread connection)	(in) - (mm) 1 1/2" - 48.3	1 1/2" - 48.3	1 1/2" - 48.3	1 1/2" - 48.3	2" - 60.3	2" - 60.3	2" - 60.3	2" - 60.3	2 1/2" - 76.1	2 1/2" - 76.1
Water content volume	(l) 1.44	1.44	1.44	1.44	1.80	4.32	4.32	4.32	5.76	5.76
Antifreeze Heater Max Power Input (Standard Digit 19=N or C / Process Digit 19=P)	(W) 60 / 60	60 / 60	60 / 60	120 / 60	120 / 60	120 / 120	120 / 120	120 / 120	120 / 120	120 / 120
Antifreeze Heater Max Amps (Standard Digit 19=N or C / Process Digit 19=P)	(A) 0.15 / 0.15	0.15 / 0.15	0.15 / 0.15	0.3 / 0.15	0.3 / 0.15	0.3 / 0.3	0.3 / 0.3	0.3 / 0.3	0.3 / 0.3	0.3 / 0.3

Table 14 – General Data for Partial Heat recovery CGAF 080-190 Extra Efficiency

	CGAF 80 XE	CGAF 90 XE	CGAF 100 XE	CGAF 110 XE	CGAF 130 XE	CGAF 140 XE	CGAF 150 XE	CGAF 165 XE	CGAF 180 XE	CGAF 190 XE
Partial Heat recovery (PHR) option										
Heat-Exchanger Type	Stainless steel Copper Brazed plate Heat exchanger									
Digit 19=N or C										
Heat-Exchanger Model	B12MT/ D-60	B12MT/ D-80	B12MT/ D-80	B35TM4/ D-48	B35TM4/ D-48	B35TM4/ D-64	B35TM4/ D-64	B35TM4/ D-64	B35TM4/ D-64	B35TM4/ D-64
Water connection size (Thread connection)	(in) - (mm) 1 1/2" - 48.3	2" - 60.3	2" - 60.3	2" - 60.3	2" - 60.3	2 1/2" - 76.1	2 1/2" - 76.1	2 1/2" - 76.1	2 1/2" - 76.1	2 1/2" - 76.1
Water content volume	(l) 1.80	2.40	2.40	4.32	4.32	5.76	5.76	5.76	5.76	5.76
Digit 19=P										
Heat-Exchanger Model	B12MT/ D-48	B12MT/ D-48	B12MT/ D-48	B12MT/ D-48	B12MT/ D-60	B35TM4/ D-48	B35TM4/ D-48	B35TM4/ D-48	B35TM4/ D-64	B35TM4/ D-64
Water connection size (Thread connection)	(in) - (mm) 1 1/2" - 48.3	1 1/2" - 48.3	1 1/2" - 48.3	1 1/2" - 48.3	2" - 60.3	2" - 60.3	2" - 60.3	2" - 60.3	2 1/2" - 76.1	2 1/2" - 76.1
Water content volume	(l) 1.44	1.44	1.44	1.44	1.80	4.32	4.32	4.32	5.76	5.76
Antifreeze Heater Max Power Input (Standard Digit 19=N or C / Process Digit 19=P)	(W) 60 / 60	60 / 60	60 / 60	120 / 60	120 / 60	120 / 120	120 / 120	120 / 120	120 / 120	120 / 120
Antifreeze Heater Max Amps (Standard Digit 19=N or C / Process Digit 19=P)	(A) 0.15 / 0.15	0.15 / 0.15	0.15 / 0.15	0.3 / 0.15	0.3 / 0.15	0.3 / 0.3	0.3 / 0.3	0.3 / 0.3	0.3 / 0.3	0.3 / 0.3



Optional Free-Cooling

Table 15 – General Data for Partial Heat recovery CXAF 080-190 Standard Efficiency

		CXAF 80	CXAF 90	CXAF 100	CXAF 80	CXAF 90	CXAF 100	CXAF 110	CXAF 130	CXAF 140	CXAF 150	CXAF 165	CXAF 180	CXAF 190
		SSE	SSE	SSE	SE	SE	SE	SE	SE	SE	SE	SE	SE	SE
Partial Heat recovery (PHR) option														
Heat-Exchanger Type		Stainless steel Copper Brazed plate Heat exchanger												
Digit 19=N or C														
Heat-Exchanger Model		B12MT/ D-60	B12MT/ D-80	B12MT/ D-80	B12MT/ D-60	B12MT/ D-80	B12MT/ D-80	B35TM4/ D-48	B35TM4/ D-48	B35TM4/ D-64	B35TM4/ D-64	B35TM4/ D-64	B35TM4/ D-64	B35TM4/ D-64
Water connection size (Thread connection)	(in) - -(mm)	1 1/2 - 48.3	2" - 60.3	2" - 60.3	1 1/2 - 48.3	2" - 60.3	2" - 60.3	2" - 60.3	2" - 60.3	2 1/2 - 76.1	2 1/2 - 76.1	2 1/2 - 76.1	2 1/2 - 76.1	2 1/2 - 76.1
Water content volume	(l)	1.8	2.4	2.4	1.8	2.4	2.4	4.32	4.32	5.76	5.76	5.76	5.76	5.76
Digit 19=P														
Heat-Exchanger Model		B12MT/ D-48	B12MT/ D-48	B12MT/ D-48	B12MT/ D-48	B12MT/ D-48	B12MT/ D-48	B12MT/ D-48	B12MT/ D-60	B35TM4/ D-64	B35TM4/ D-64	B35TM4/ D-64	B35TM4/ D-64	B35TM4/ D-64
Water connection size (Thread connection)	(in) - (mm)	1 1/2 - 48.3	1 1/2 - 48.3	1 1/2 - 48.3	1 1/2 - 48.3	1 1/2 - 48.3	1 1/2 - 48.3	1 1/2 - 48.3	2" - 60.3	2" - 60.3	2" - 60.3	2" - 60.3	2 1/2 - 76.1	2 1/2 - 76.1
Water content volume	(l)	1.44	1.44	1.44	1.44	1.44	1.44	1.44	1.8	4.32	4.32	4.32	4.32	4.32
Antifreeze Heater Max Power Input (Standard Digit 19=N or C / Process Digit 19=P)	(W)	60 / 60	60 / 60	60 / 60	60 / 60	60 / 60	60 / 60	120 / 60	120 / 60	120 / 120	120 / 120	120 / 120	120 / 120	120 / 120
Antifreeze Heater Max Amps (Standard Digit 19=N or C / Process Digit 19=P)	(A)	0.15 / 0.15	0.15 / 0.15	0.15 / 0.15	0.15 / 0.15	0.15 / 0.15	0.15 / 0.15	0.15 / 0.15	0.3 / 0.15	0.3 / 0.15	0.3 / 0.3	0.3 / 0.3	0.3 / 0.3	0.3 / 0.3

Table 16 – General Data for Partial Heat recovery CXAF 080-190 High Efficiency

		CXAF 80	CXAF 90	CXAF 100	CXAF 80	CXAF 90	CXAF 100	CXAF 110	CXAF 130	CXAF 140	CXAF 150	CXAF 165	CXAF 180	CXAF 190
		SHE	SHE	SHE	HE	HE	HE	HE	HE	HE	HE	HE	HE	HE
Partial Heat recovery (PHR) option														
Heat-Exchanger Type		Stainless steel Copper Brazed plate Heat exchanger												
Digit 19=N or C														
Heat-Exchanger Model		B12MT/ D-60	B12MT/ D-80	B12MT/ D-80	B12MT/ D-60	B12MT/ D-80	B12MT/ D-80	B35TM4/ D-48	B35TM4/ D-48	B35TM4/ D-64	B35TM4/ D-64	B35TM4/ D-64	B35TM4/ D-64	B35TM4/ D-64
Water connection size (Thread connection)	(in) - -(mm)	1 1/2 - 48.3	2" - 60.3	2" - 60.3	1 1/2 - 48.3	2" - 60.3	2" - 60.3	2" - 60.3	2" - 60.3	2 1/2 - 76.1	2 1/2 - 76.1	2 1/2 - 76.1	2 1/2 - 76.1	2 1/2 - 76.1
Water content volume	(l)	1.8	2.4	2.4	1.8	2.4	2.4	4.32	4.32	5.76	5.76	5.76	5.76	5.76
Digit 19=P														
Heat-Exchanger Model		B12MT/ D-48	B12MT/ D-48	B12MT/ D-48	B12MT/ D-48	B12MT/ D-48	B12MT/ D-48	B12MT/ D-48	B12MT/ D-60	B35TM4/ D-48	B35TM4/ D-48	B35TM4/ D-48	B35TM4/ D-64	B35TM4/ D-64
Water connection size (Thread connection)	(in) - (mm)	1 1/2 - 48.3	1 1/2 - 48.3	1 1/2 - 48.3	1 1/2 - 48.3	1 1/2 - 48.3	1 1/2 - 48.3	1 1/2 - 48.3	2" - 60.3	2" - 60.3	2" - 60.3	2" - 60.3	2 1/2 - 76.1	2 1/2 - 76.1
Water content volume	(l)	1.44	1.44	1.44	1.44	1.44	1.44	1.44	1.8	4.32	4.32	4.32	4.32	4.32
Antifreeze Heater Max Power Input (Standard Digit 19=N or C / Process Digit 19=P)	(W)	60 / 60	60 / 60	60 / 60	60 / 60	60 / 60	60 / 60	120 / 60	120 / 60	120 / 120	120 / 120	120 / 120	120 / 120	120 / 120
Antifreeze Heater Max Amps (Standard Digit 19=N or C / Process Digit 19=P)	(A)	0.15 / 0.15	0.15 / 0.15	0.15 / 0.15	0.15 / 0.15	0.15 / 0.15	0.15 / 0.15	0.3 / 0.15	0.3 / 0.15	0.3 / 0.3	0.3 / 0.3	0.3 / 0.3	0.3 / 0.3	0.3 / 0.3



Optional Free-Cooling

Table 17 – General data for free cooling option sizes 080-190

		CGAF 080	CGAF 090	CGAF 100	CGAF 110	CGAF 130	CGAF 140	CGAF 150	CGAF 165	CGAF 180	CGAF 190
Free-Cooling Heat-Exchanger Type		Full aluminium Micro channel heat exchanger									
Fan / motor Type		Propeller fan : Fixed speed AC motor / Variable speed EC motor									
Digit 56=1											
Fan / motor Type		Propeller fan : Fixed speed AC motor									
Power per Motor	kW	1.49	1.49	1.49	1.49	1.49	1.49	1.49	1.49	1.49	1.49
Motor RPM	RPM	900	900	900	900	900	900	900	900	900	900
Digit 56=2											
Fan / motor Type		Propeller fan : Variable speed EC motor									
Power per Motor (Digit12 = N)	kW	2.27	2.27	2.27	2.27	2.27	2.27	2.27	2.27	2.27	2.27
Motor RPM (Digit12 = N)	RPM	1000	1000	1000	1000	1000	1000	1000	1000	1000	1000
Power per Motor (Digit12 = H)	kW	2.28	1.67	1.67	2.28	2.28	2.28	2.28	2.28	2.28	2.28
Motor RPM (Digit12 = H)	RPM	1000	910	910	1000	1000	1000	1000	1000	1000	1000
Digit 56=3											
Fan / motor Type		Propeller fan : Variable speed EC motor									
Power per Motor	kW	2.07	1.61	1.61	2.07	2.07	2.07	2.07	2.07	2.07	2.07
Motor RPM	RPM	1000	1000	1000	1000	1000	1000	1000	1000	1000	1000
Water connection size	(in) - (mm)	4" - 114.3	4" - 114.3	4" - 114.3	4" - 114.3	4" - 114.3	5" - 139.7	5" - 139.7	5" - 139.7	5" - 139.7	5" - 139.7
Additional Width	mm	245	245	245	245	245	245	245	245	245	245
Direct Free-Cooling Option (4)											
Total Free-Cooling Option		Total Free-Cooling (Digit 25 = F)									
Digit 12=N											
Coils quantity		-	4	4	4	4	6	6	6	8	8
FC Pump Max Motor Power	kW	-	2.3	2.3	2.3	2.3	2.56	2.56	2.56	3	3
FC Pump Rated Amps	A	-	4.3	4.3	4.3	4.3	5.8	5.8	5.8	6.15	6.15
Summer nominal water flow	L/s	-	16.0	17.6	19.5	21.4	23.7	25.9	27.8	31.1	33.0
Summer unit pressure drop	kPa	-	117.5	118.8	126.1	126.4	106.7	105.0	104.1	115.0	118.0
Direct Free-Cooling Capacity	kW	-	215.0	215.3	215.8	214.8	337.2	337.3	337.5	464.0	489.7
Winter customer pressure drop	kPa	-	88.0	85.1	87.3	66.7	75.2	68.1	62.3	60.7	55.6
Antifreeze Heater**	W	-	240	240	240	240	240	240	240	240	240
Additional shipping weight	kg	-	325	325	325	325	455	455	455	565	565
Additional water content	L	-	67.33	67.33	67.33	67.33	81.09	81.09	81.09	94.86	94.86
Digit 12=H or Digit 12=A											
Coils quantity		4	6	6	6	6	8	8	8	10	10
FC Pump Max Motor Power	kW	2.3	2.56	2.56	2.56	2.56	3	3	3	3	3
FC Pump Rated Amps	A	4.3	5.8	5.8	5.8	5.8	6.15	6.15	6.15	6.15	6.15
Summer nominal water flow	L/s	14.8	17.0	18.8	21.0	23.1	25.1	27.6	29.4	32.3	34.3
Summer unit pressure drop	kPa	75.3	97.1	98.8	107.4	117.5	77.1	83.8	94.9	113.2	121.4
Direct Free-Cooling Capacity	kW	214.8	332.3	332.9	333.6	332.1	463.8	463.8	463.9	558.3	558.5
Winter customer pressure drop	kPa	48.9	60.1	55.5	56.6	45.2	40.8	40.4	45.8	54.6	56.2
Antifreeze Heater**	W	240	240	240	240	240	240	240	240	240	240
Additional shipping weight	kg	325	415	415	415	415	565	565	565	660	660
Additional water content	L	67.33	81.09	81.09	81.09	81.09	94.86	94.86	94.86	108.62	108.62
Glycol Free Option											
Total Free Cooling type		Total Free-Cooling (Digit 25 = H)									
Digit 12=N											
Coils quantity		-	4	4	4	4	6	6	6	8	8
Summer nominal water flow	L/s	-	14.8	16.3	18.0	19.8	21.9	23.9	25.6	28.7	30.5
Summer & winter unit pressure drop	kPa	-	118.5	125.7	139.1	97.0	89.3	90.1	91.3	85.4	87.6
Glycol Free - Free-Cooling Capacity	kW	-	175.5	176.6	177.6	174.6	265.6	268.3	270.2	374.0	380.1
Glycol Pump Motor Power	kW	-	2.3	2.3	2.3	2.3	2.56	2.56	2.56	3	3
Glycol Pump Rated Amps	A	-	4.3	4.3	4.3	4.3	5.8	5.8	5.8	6.15	6.15
FC BPHE Model		-	B427M2+ M1x118	B427M2+ M1x118	B427M2+ M1x118	B427M2+ M1x118	B427M2+ M1x152	B427M2+ M1x152	B427M2+ M1x152	B427H+ M2x260	B427H+ M2x260
Antifreeze Heater**	W	-	480	480	480	480	480	480	480	640	640
Additional shipping weight	kg	-	405	405	405	405	555	555	555	720	720
Glycol content	L	-	167	167	167	167	228	228	228	304	304



Optional Free-Cooling

Table 17 – General data for free-cooling option sizes 080-190 (Continued)

	CGAF 080	CGAF 090	CGAF 100	CGAF 110	CGAF 130	CGAF 140	CGAF 150	CGAF 165	CGAF 180	CGAF 190
Digit 12=H or Digit 12=A										
Coils quantity	4	6	6	6	6	8	8	8	10	10
Summer nominal water flow	L/s	13.7	15.7	17.4	19.4	21.3	23.2	25.4	27.2	29.8
Summer & winter unit pressure drop	kPa	83.3	90.7	96.0	107.6	76.0	57.6	62.6	70.8	78.3
Glycol Free - Free-Cooling Capacity	kW	174.4	261.9	264.6	267.1	260.4	363.7	368.5	371.6	445.7
Glycol Pump Motor Power	kW	2.3	2.56	2.56	2.56	2.56	3	3	3	3
Glycol Pump Rated Amps	A	4.3	5.8	5.8	5.8	5.8	6.15	6.15	6.15	6.15
FC BPHE Model		B427M2+ M1x118	B427M2+ M1x152	B427M2+ M1x152	B427M2+ M1x152	B427M2+ M1x152	B427H+ M2x260	B427H+ M2x260	B427H+ M2x260	B427H+ M2x294
Antifreeze Heater**	W	480	480	480	480	480	640	640	640	640
Additional shipping weight	kg	405	520	520	520	520	720	720	720	835
Glycol content	L	167	227	227	227	227	304	304	304	363

(1) FC winter mode condition: EWT=20C, AmbT=0C

(2) 30% EG is used in glycol loop for GFFC

(3) ** = No heater on BPHE water inlet, Antifreeze Heater (W) minus 60W for 080 to 140 Units & 120W from 150 to 190 Units.

Chiller Integrated Free-Cooling Operation Mode

The power of chiller integrated free-cooling relies on the chiller control to maximize the use of free-cooling when outdoor temperatures are favorable. The choice between compressor refrigeration and Free-cooling refrigeration will be made and activated depending on three temperature measurements:

- The ambient air temperature
- The evaporator entering and leaving temperature
- The chilled water set point

Free-cooling coils are fit in series with the evaporator, and a set of water regulation valves allows the coils to be by-passed when they are no longer needed due to outdoor temperatures which are favorable for free-cooling.

Three operating modes can be differentiated:

1. Summer operation or Compressor refrigeration mode

In this operation mode, ambient temperature is higher than the temperature of the fluid entering the evaporator. Free-cooling is not activated, compressors are running, and control is done in function of the fan/compressor logic of operation.

2. Mid-season operation or combined refrigeration + Free-cooling mode

In this operation mode, free-cooling will be enabled whenever the outdoor temperature is below the evaporator entering water temperature. The operating logic is described below. The free-cooling system operates combined with the mechanical compressor refrigeration. Most of the time, free-cooling will only partially cover the required cooling duty. In other words, mechanical refrigeration will complete what has already been delivered by free-cooling.

3. Winter operation or full free-cooling mode

Below a certain ambient temperature, and depending on the chilled water set point requested, the entire cooling duty is delivered by the free-cooling system. Compressors do not operate, since the free-cooling coils will be able to deliver the requested chilled water temperature. The regulation of the capacity is described in the next section. In this mode, only fans are running.

General Information

The chiller integrated free-cooling system fluid based consist in a set of "Macro-channels" or "Radiators" coils, fit in the same frame than the MCHE condenser coils of the chiller refrigeration circuit. Free-cooling coils will be full aluminium, flat radiator design type, with low air pressure drop to avoid fan performance degradation.

Free-cooling coils are fit in series with the evaporator, and a set of water regulation valves ensures the system to reach the required free-cooling capacity.

Optional Free-Cooling

Figure 21 – Total Free-Cooling option

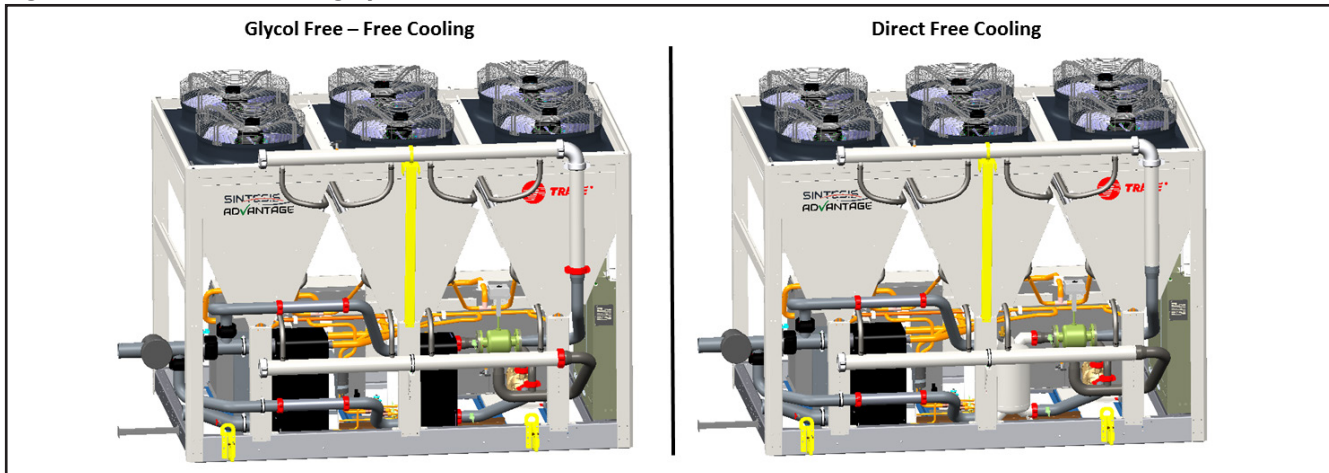

If there is a need to get a definition for partial heat recovery coil distribution, please contact the Trane sales office.

Free-Cooling Enabling Conditions:

To get the free-cooling active, condition is to have unit in active cooling mode and that Outdoor temperature low enough according to figure below.

The free-cooling function is enabled when outdoor air temperature is below Active chilled water cooling set point minus FC offset.

A hysteresis should also apply to avoid short cycling of Free-cooling enabling logic. The Free-cooling offset is an adjustable parameter to make free-cooling active.

If free-cooling function is enabled, free-cooling becomes the 1st stage of cooling. Free-cooling is the first stage to engage for cooling capacity loading and the last stage to consider in capacity unloading.

Figure 22 – Free-cooling enabling conditions

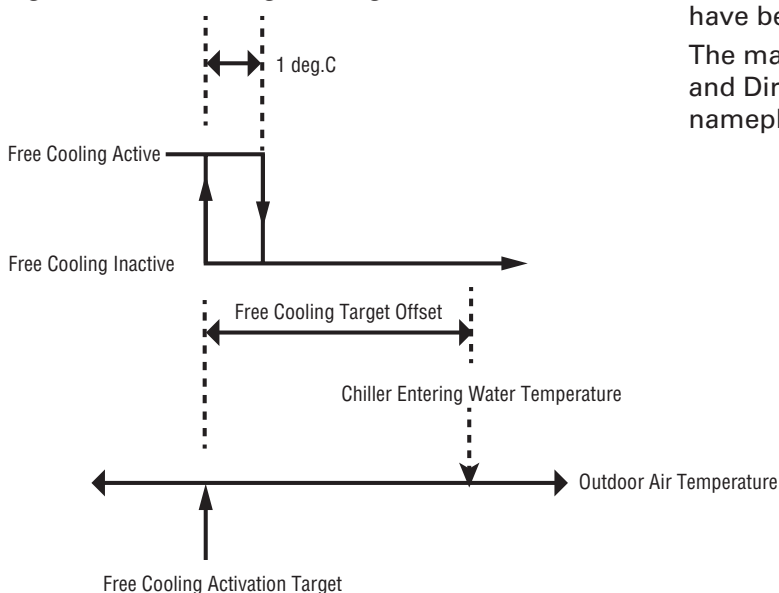

In Order to maximize tandem operation of free-cooling with compressor the following logic is applied:

When unit is configured in “Partial free cooling”, when free-cooling reached its full capacity and there is a call for compressor start, the first circuit to start shall be circuit2 (if available). This also means compressor balancing function is disabled in these conditions.

Note: Tracer™ UC800/Symbio800 will not lockout compressor below free-cooling change over point, but the compressor is locked out when outdoor air is below “low ambient limit” set at -10°C. So FC will be the only source of cooling below -10°C.

Note for installation: All Submittal, lifting diagram, neoprene pads positioning, and wiring diagrams have been supplied with chiller order.

The maximum pressure for unit with Glycol free and Direct free-cooling is 400kPa. Refer to unit nameplate for rated value.



Optional Free-Cooling

Pump Operating with Glycol Free: It is requested to have a minimum water side pressure of 250kPa to avoid cavitation.

Glycol free Option: To avoid component damage, a filter (1mm mesh) must be supplied by the customer and installed at the unit inlet.

Unit is shipped without glycol content on the free-cooling circuit.

Free-cooling loop venting must be performed by using manual overload mode to run the free-cooling pump and opening free-cooling and closing bypass valve.

At 10 to 20°C ambient, the expansion shall be pressurized at 250kPa. It should be checked when glycol loop is not yet filled or glycol pressure is near zero.

All Free-cooling units must be freeze-protected with at least 30% Ethylene Glycol and to minimum ambient temperature in the cooling loop circuit in order to protect the unit against freezing. Upon receipt, make sure that there is no remaining test water in the free-cooling circuit as it may freeze during winter periods.

Water can be trapped in BPHE and specific care must be taken to remove it completely from BPHE during off mode if drainage is the winter protection chosen.

The free-cooling option circuit consists of copper, carbon steel, cast iron, zinc, synthetic rubber, brass, and Aluminium AA3102, AA3003, AA4045 in addition to other materials that may be in the building loop connected to the chiller. The inhibited glycol solution should be selected at desired concentration to ensure adequate inhibitor content. It is not advised to dilute a stronger concentrate due to inhibitor dilution. Glycol fluid should be free from foreign solid particles. A maintenance schedule should be selected per the glycol manufacturer's requirements to insure adequate protection during product usage.

Note: Equipment Damage! Failure to follow instructions below could cause equipment damage. **DO NOT USE UNTREATED WATER. Glycol solution must be utilized with Free-cooling option. Glycol percentage should be based on freeze avoidance requirements. The glycol solution requires an inhibitor package to be carefully chosen with the aid of a qualified water treatment specialist to abate corrosion in a mixed metal system.**

The building glycol loop should not be vented to atmosphere. A closed system is required to limit oxidation potential within the loop. Make-up water should be avoided.

Figure 23 – Schematic – Free-cooling option

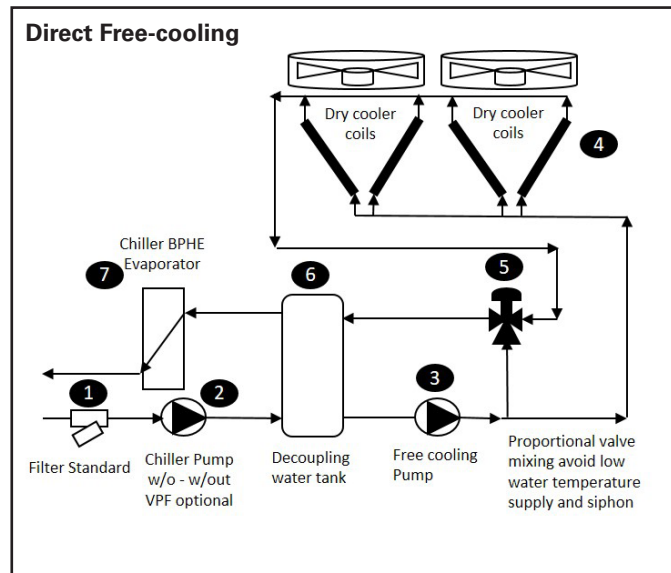

Operating Principles

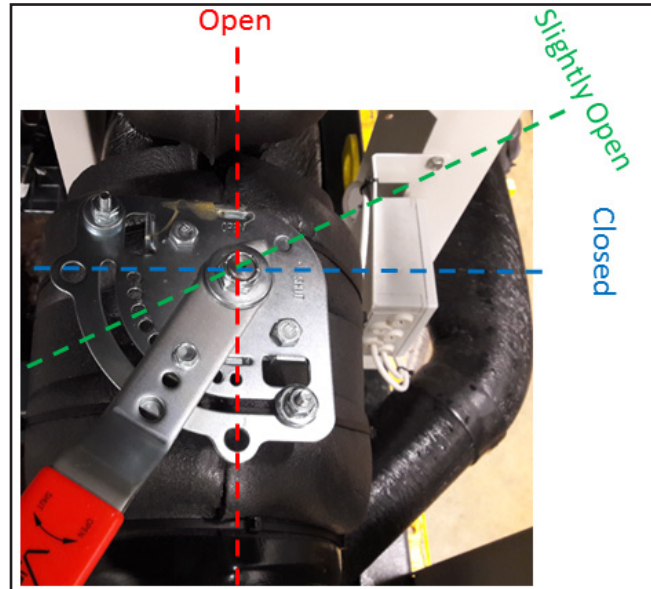
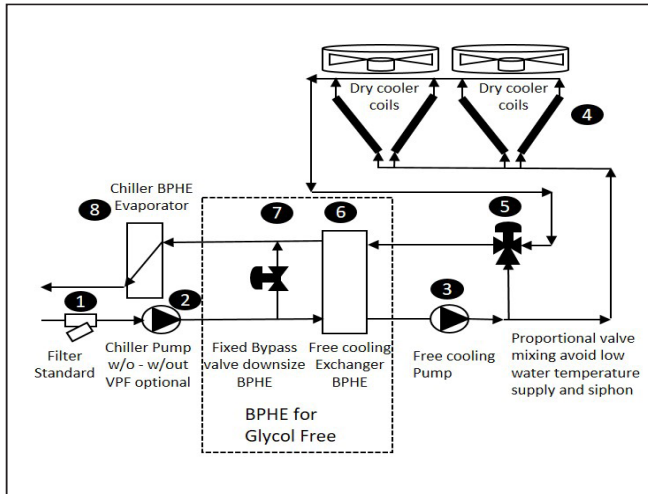

Glycol Free-cooling

Free-Cooling Bypass Valve Settings

Position 1: 0% - Closed – Free-cooling

Position 2: 10%

Position 3: 20%

.....

Position 10: 100% - Fully Open – No Free-cooling

Open position: Water flow is directed to evaporator and there will not be any free-cooling.

Closed position: All the water flow is directed to free-cooling exchanger or de coupling bottle. In Free-cooling mode water flow will see highest pressure drop.

Slightly open: 0% to 30% will direct the some portion of water through free-cooling exchanger and the remaining to evaporator.

Refer the settings table for more details.

Table 18 – Direct Free-Cooling Setting

DIRECT FC	80	90	100	110	130	140	150	165	180	190
% Open	0%	0%	0%	0%	20%	30%	30%	30%	40%	40%
Position	1/2*	1/2	1/2	1/2	3	4	4	4	5	5

Table 19 – Glycol Free Free-Cooling Setting

DIRECT FC	80	90	100	110	130	140	150	165	180	190
% Open	0%	0%	0%	0%	20%	20%	20%	30%	30%	30%
Position	1/2	1/2	1/2	1/2	3	3	4	4	4	4

Note for maintenance: Check glycol circuit pressure before free-cooling operation season starts. Run glycol pump few minutes in manual override during monthly maintenance operation when free-cooling is continuously OFF to avoid possible glycol crystallization. Pump Override function is located in TD7 via Button Settings -> Manual Control Settings -> Free-cooling Pump Override.

Option Free-Cooling

Figure 24 – Example of Hydronic Group Schematic Pump Package / Free-Cooling for CGAF

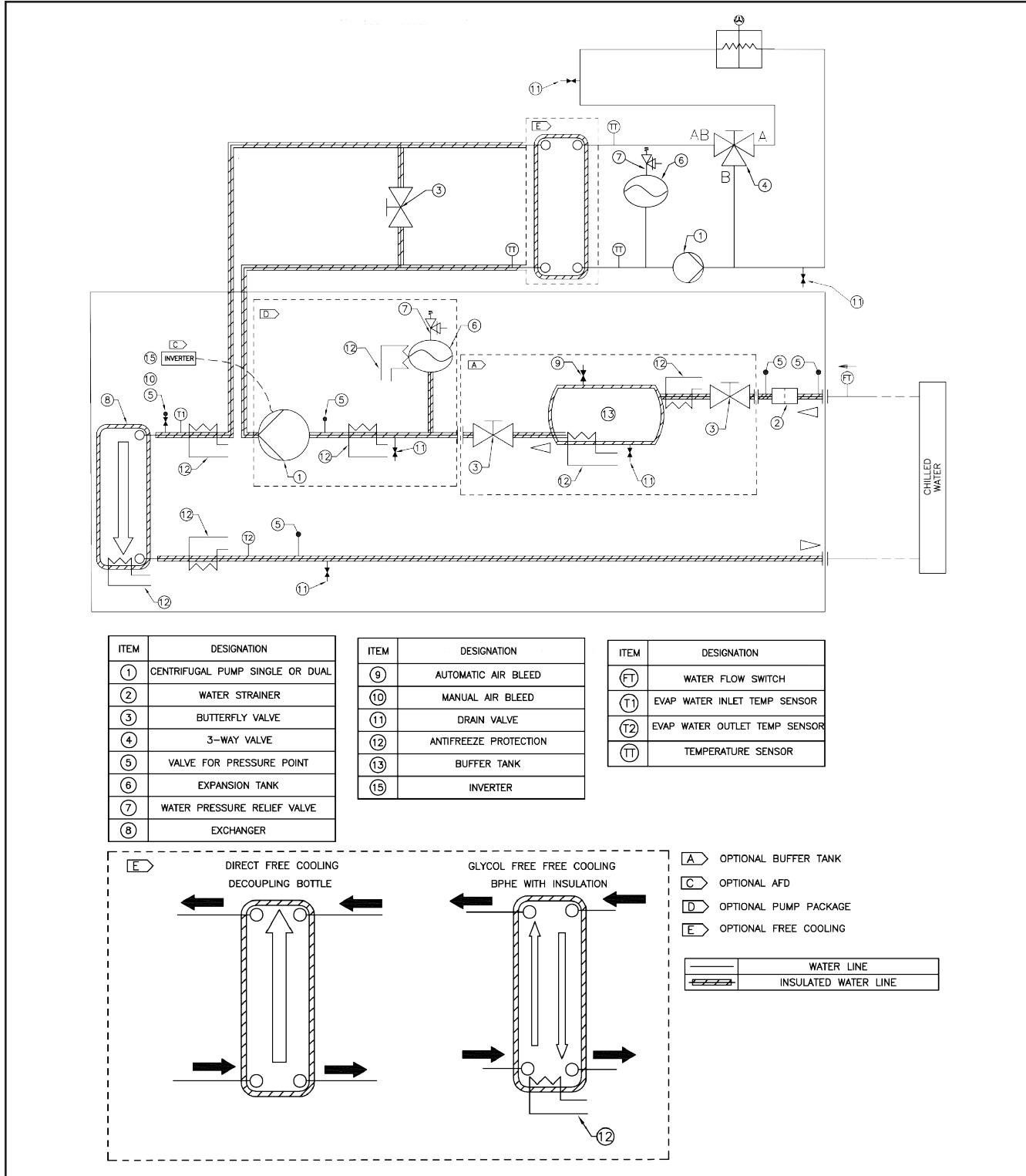

Note: Glycol free - free-cooling chilled water set point should be in the range of (4°C-20°C). Water Glycol mixing is filled on the free-cooling coils on valve item 11.

Option Free-Cooling

Figure 25 – Free-Cooling Operating Maps

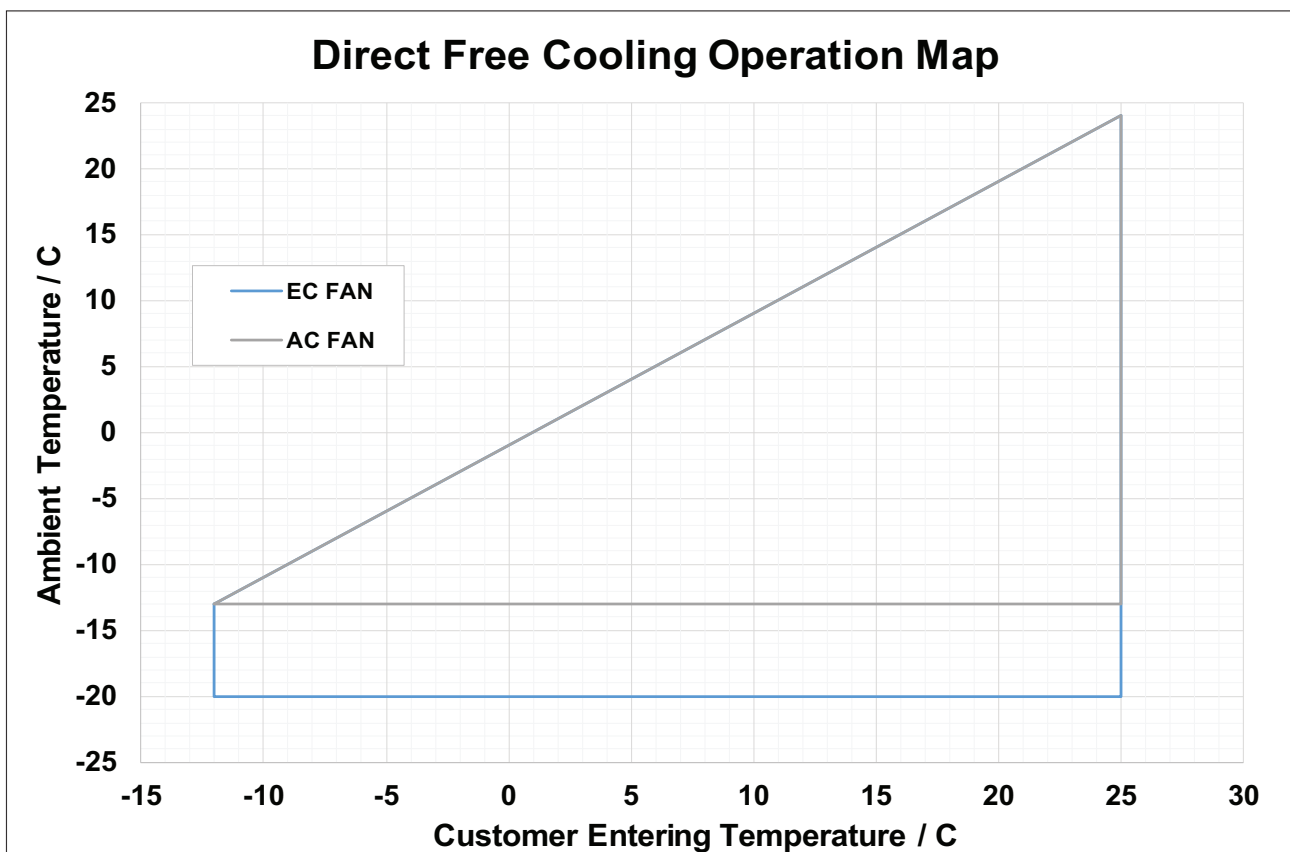
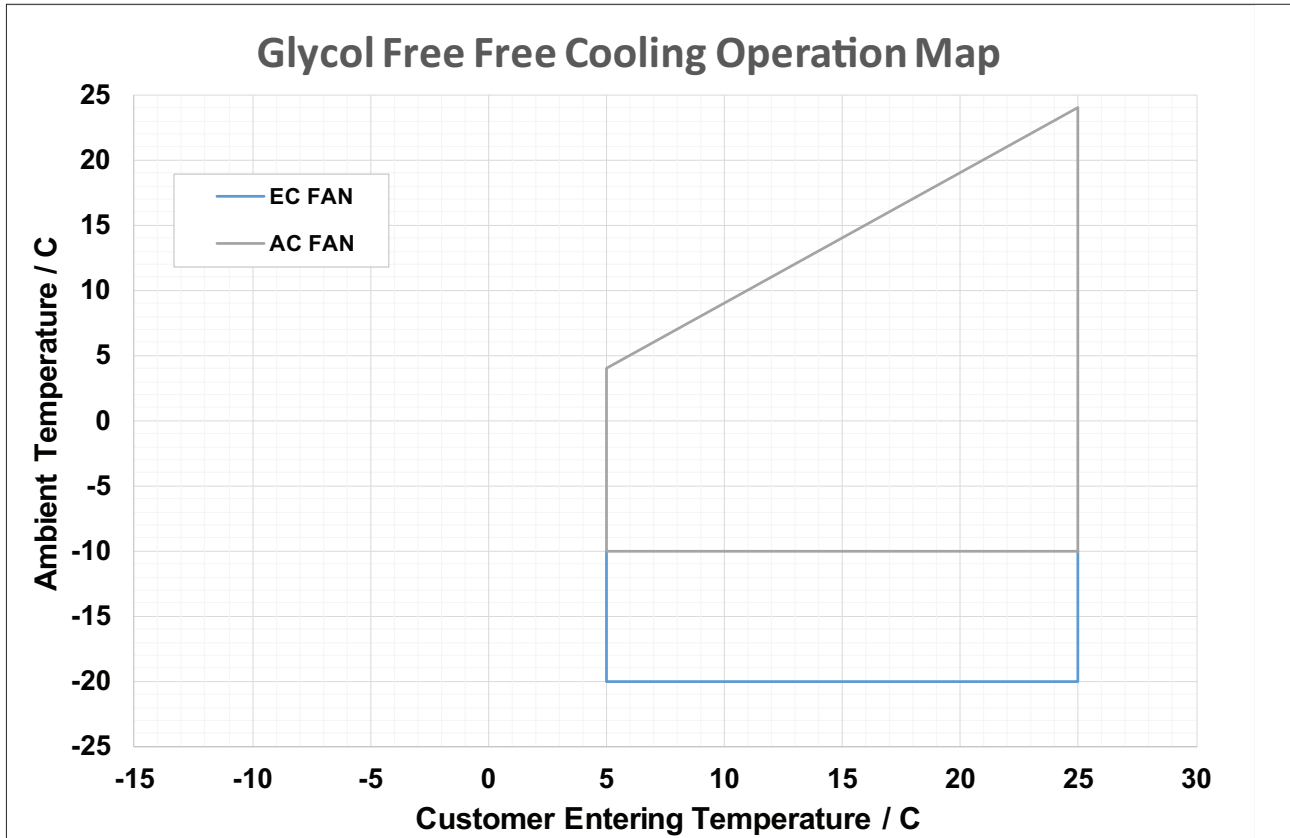

Option Free-Cooling

Figure 26 – Free-Cooling Water pressure drop

The free-cooling water pressure drops given in charts below (coil + valve) should be added to evaporator pressure drop to get full unit pressure drop.

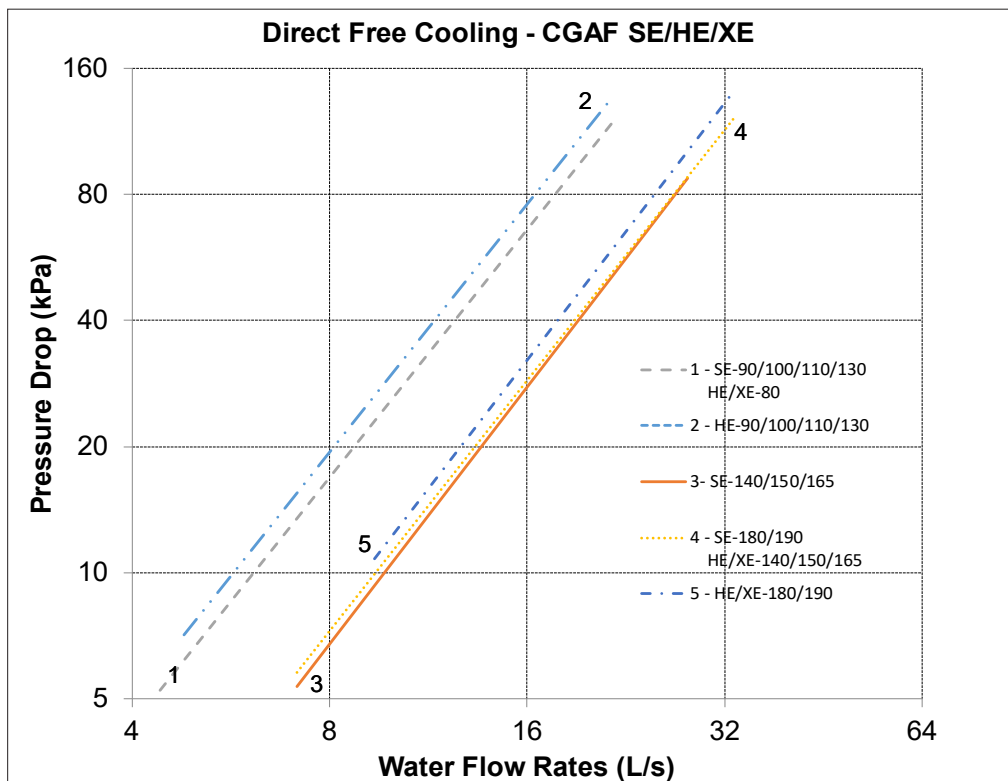
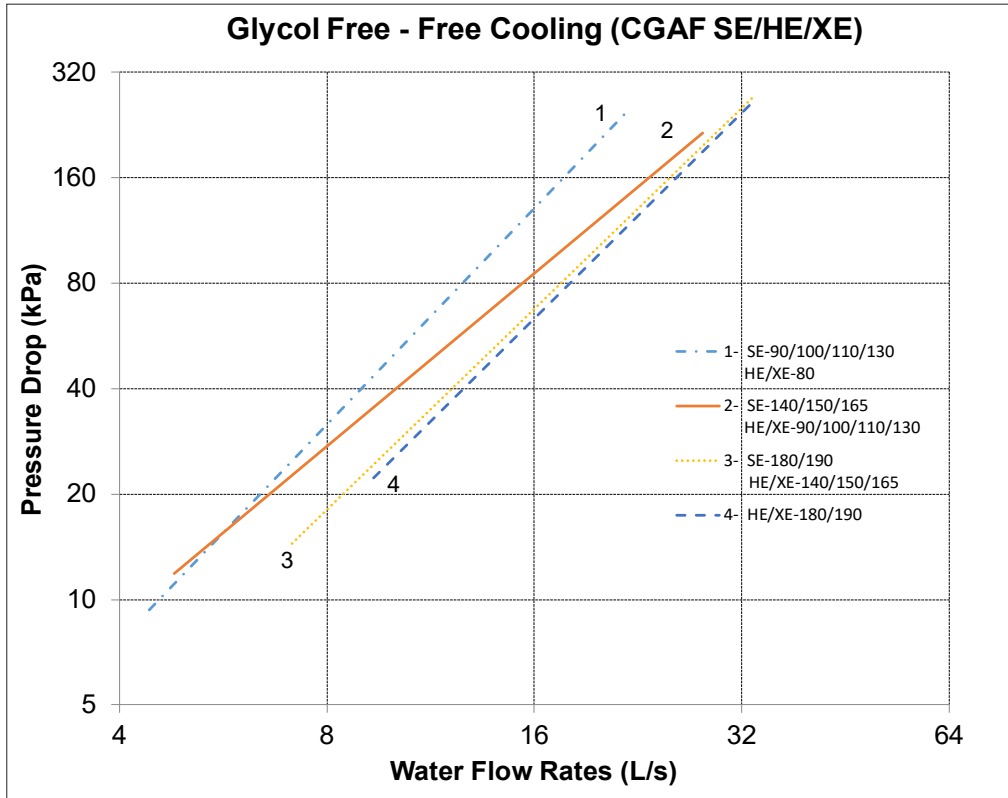



Controls/Tracer TD7 Operator Interface

Controls Overview

Sintesis CGAF / CXAF units use the following control/interface components:

- Tracer™ UC800/Symbio800 Controller
- Tracer TD7 Operator Interface

Communication Interfaces

There are four connections on the Tracer™ UC800/Symbio800 that support the communication interface. See CGAF / CXAF User Guide to locate the following ports: "Wiring and Ports Description" section.

- BACnet MS/TP
- BACnet IP (Only with Symbio800)
- MODBUS RTU
- MODBUSTCP (Only with Symbio800)
- LonTalk

See User Guide for information on communication interface.

Tracer TD7 Operator Interface

Operator Interface

Information is tailored to operators, service technicians and owners. When operating a chiller, there is specific information you need on a day-to-day basis, like set points, limits, diagnostic information, and reports.

Day-to-day operational information is presented at the display. Logically organized groups of information-chiller mode of operation, active diagnostics, settings and reports put information conveniently at your fingertips.

Tracer™ TU

The TD7 operator interface allows for daily operation tasks and set point changes. However to adequately service Sintesis CGAF chillers / CXAF Heat Pump, Tracer™ TU service tool is required (Non-Trane personnel, contact your local Trane office for software purchase information). Tracer TU adds a level of sophistication that improves service technician effectiveness and minimizes chiller downtime. This portable PC-based service-tool software supports service and maintenance tasks.



Pre-Start Checkout

Installation Checklist

Complete this checklist as the unit is installed, and verify that all recommended procedures are accomplished before the unit is started. This checklist does not replace the detailed instructions given in the "Installation Mechanical" and "Installation Electrical" sections of this manual. Read both sections completely, to become familiar with the installation procedures, prior beginning the work.

General

When installation is complete, before starting the unit, the following prestart procedures must be reviewed and verified:

Caution : Follow proper lockout/tagout procedures to ensure the power can not be inadvertently energized. Failure to disconnect power before servicing could result in death or serious injury

WARNING Live Electrical Components! During installation, testing, servicing and troubleshooting of this product, it may be necessary to work with live electrical components. Have a qualified licensed electrician or other individual who has been properly trained in handling live electrical components perform these tasks. Failure to follow all electrical safety precautions when exposed to live electrical components could result in death or serious injury.

1. Inspect all wiring connections in the compressor power circuits (disconnects, terminal block, contactors, compressor junction box terminals and so forth) to ensure they are clean and tight.
2. Verify that all refrigerant valves in the discharge, liquid, and oil return lines are "OPEN".
3. Check the power-supply voltage to the unit at the main-power fused-disconnect switch. Voltage must be within the voltage use range and stamped on the unit nameplate. Voltage fluctuation must not exceed 10%. Voltage imbalance must not exceed 2%.
4. Check the unit power phasing L1-L2-L3 in the starter to ensure that it has been installed in a "A-B-C" phase sequence.
5. Fill the evaporator chilled water circuit. Vent the system while it is being filled. Open the vents on the top of the evaporator during filling and close when filling is completed.
6. Close the fused-disconnect switch(es) that supplies power to the chilled water pump starter.
7. Start the chilled water pump to begin circulation of the water. Inspect all piping for leakage and make any necessary repairs.
8. With water circulating through the system, adjust the water flow and check the water pressure drop through the evaporator.
9. Adjust the chilled water flow switch for proper

- operation.
10. Apply power to complete the procedures.
11. Prove all interlock and interconnecting wiring interlock and external as described in the electrical installation section.
12. Check and set, as required, all Tracer™ UC800/Symbio800TD7 menu items.
13. Stop the chilled water pump.
14. Energize the compressor and oil separator heaters 24 hours, prior to unit start-up.

Unit Voltage Power Supply

Unit voltage must meet the criteria given in the electrical installation section. Measure each lead of the supply voltage at the main power fused-disconnect switch for the unit. If the measured voltage on any lead is not within the specified range, notify the supplier of the power and correct the situation before operating the unit.

Unit Voltage Imbalance

Excessive voltage imbalance between the phases of a three-phase system can cause motors to overheat and eventually fail. The maximum allowable unbalance is 2%. Voltage imbalance is determined using the following calculations:
$$\% \text{ Imbalance} = [(V_x - V_{ave}) \times 100 / V_{ave}]$$
$$V_{ave} = (V_1 + V_2 + V_3) / 3$$
$$V_x = \text{phase with greatest difference from } V_{ave} \text{ (without regard to the sign)}$$

Unit Voltage Phasing

It is important that proper rotation of the compressors be established before the unit is started. Proper motor rotation requires confirmation of the electrical phase sequence of the power supply. The motor is internally connected for clockwise rotation with the incoming power supply phases A-B-C.

When rotation is clockwise, the phase sequence is usually called "ABC", when counterclockwise "CBA"

This direction may be reversed by interchanging any two of the line wires.

1. Stop the unit from TD7/Tracer™ UC800/Symbio800.
2. Open the electrical disconnect or circuit protection switch that provides line power to the line power terminal block(s) in the starter panel (or to the unit mounted disconnect).
3. Connect the phase-sequence indicator leads to the line power terminal block (L1-L2-L3).
4. Turn power on by closing the unit supply-power fused-disconnect switch.
5. Read the phase sequence on the indicator. The ABC LED of the phase indicator will glow.

Pre-Start Checkout

WARNING! It is imperative that L1, L2, and L3 in the starter be connected in the A-BC phase sequence to prevent equipment damage due to reverse rotation.

WARNING! To prevent injury or death due to electrocution, take extreme care when performing service procedures with electrical power energized.

CAUTION! Do not interchange any load leads that are from the unit contactors or the motor terminals. Doing so may damage the equipment.

Water System Flow Rates

Establish a balanced chilled water flow through the evaporator. The flow rates should be between the minimum and maximum values given on the pressure drop curves.

Water System Pressure Drop

Measure the water-pressure drop through the evaporator on the field installed pressure taps on the system water piping. Use the same gauge for each measurement. Do not include valves, strainers, or fittings in the pressure drop readings.

Integrated Pump Package (Optional)

Before starting up the pump, the pipe system must be thoroughly cleaned, flushed and filled with clean water. Do not start the pump until it has been vented. To ensure correct venting, open the vent screw located on the pump housing on the suction side (see next figure).

Figure 27 – Pump Package

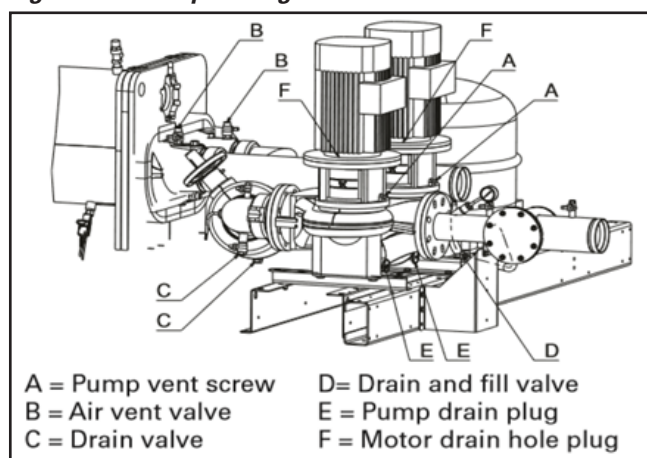

CAUTION! When using freeze inhibitor, never fill the system with pure glycol; this will damage the shaft seal. Always fill the system with diluted solution. Maximum concentration of glycol is 40% for unit with pump package.

CAUTION! Failure to operate pump w/o water or insert high glycol concentration will lead to premature seal damage and void the warranty.

CG-SVX039E-GB

If the chiller is installed in a humid environment or a location with high air humidity, the bottom drain hole on the pump motor should be opened. The enclosure class of the motor is then changed from IP55 to IP44. The function of the drain holes is to drain off water which has entered the stator housing with air humidity.

Tracer™UC800 and Symbio800 Set-Up

Using TracerTU service tool, adjust the settings. Refer to TracerTU manual and Tracer™ UC800/Symbio800 user guide for instruction on settings.

CAUTION! To prevent compressor damage, do not operate the unit until all refrigerant valves and oil-line service valves are opened.

IMPORTANT! A clear sight glass alone does not mean that the system is properly charged. Also check system discharge superheat, approach temperature and unit operating pressures.



Unit Start Up Procedures

Daily Unit Start Up

The time line for the sequence of operation begins with a power-up of the main power to the chiller. The sequence assumes 2 circuits, 2 compressors, Sintesis air cooled CGAF chiller with no diagnostics or malfunctioning components. External events such as the operator placing the chiller in AUTO or STOP, chilled water flow through the evaporator, and application of load to the chilled water loop causing loop water-temperature increases, are depicted and the chiller responses to those events are shown, with appropriate delays noted. The effects of diagnostics, and other external interlocks other than evaporator water-flow proving, are not considered.

Note: unless the Tracer™ UC800/Symbio800/TD7 and building automation system are controlling the chilled water pump, the manual unit start sequence is as follows. Operator actions are noted.

General

If the present checkout, as discussed above, has been completed, the unit is ready to start.

1. Press the STOP key on the TD7 display.
2. As necessary, adjust the set point values on the TD7 menus using Tracer TU.
3. Close the fused-disconnect switch for the chilled-water pump. Energize the pump(s) to start water circulation
4. Check the service valves on the discharge line, suction line, oil line, and liquid line for each circuit. These valves must be open (back seated) before starting the compressors.
5. Verify that chilled water pump runs for at least one minute after the chiller is commanded to stop (for normal chilled water systems).
6. Press the AUTO key. If the chiller control calls for cooling, and all safety interlocks are closed, the unit will start. The compressor(s) will load and unload in response to the leaving chilled – water temperature.

After the system has been operating for approximately 30 minutes and has become stabilized, complete the remaining start up procedures, as follows:

1. Check the evaporator refrigerant pressure and the condenser refrigerant pressure under Refrigerant Report on the TD7.
2. Check the EXV sight glasses after enough time has elapsed to stabilize the chiller. The refrigerant flow through the sight glasses should be clear. Bubbles in the refrigerant indicate either low refrigerant charge or excessive pressure drop in the liquid line, or an expansion valve that is stuck open. A restriction in the line can sometimes be identified by a noticeable temperature differential between the two sides of

the restriction. Frost will often form on the line at this point. Proper refrigerant charges are shown in the General Information Section.

Seasonal Unit Startup Procedure

1. Close all valves and reinstall the drain plugs in the evaporator.
2. Service the auxiliary equipment according to the startup and maintenance instructions provided by the respective equipment manufacturers.
3. Close the vents in the evaporator chilled water circuits.
4. Open all the valves in the evaporator chilled water circuits.
5. Open all refrigerant valves.
6. If the evaporator was previously drained, vent and fill the evaporator and chilled water circuit. When all air is removed from the system (including each pass), install the vent plugs in the evaporator water boxes.
7. Check the adjustment and operation of each safety and operating control.
8. Close all disconnect switches.
9. Refer to the sequence for daily unit start up for the remainder of the seasonal start up.

CAUTION! Ensure that the compressor and heaters have been operating for a minimum of 24 hours before starting. Failure to do so may result in equipment damage.

System Restart After Extended Shutdown

1. Verify that the liquid-line service valves, compressor discharge service valves, and optional suction service valves are open (back seated).
2. Check the oil level (see Maintenance procedures section).
3. Fill the evaporator water circuit. Vent the system while it is being filled. Open the vent on the top of the evaporator while filling, and close it when filling is completed.
4. Close the fused-disconnect switches that provide power to the chilled water pump.
5. Start the evaporator water pump and, while water is circulating, inspect all piping for leakage. Make any necessary repairs before starting the unit.
6. While the water is circulating, adjust the water flow and check the water pressure drops through the evaporator. Refer to “water-system flow rates” and “water-system pressure drop”.
7. Adjust the flow switch on the evaporator piping for proper operation.
8. Stop the water pump. The unit is now ready for startup as described “Startup procedures”.



Unit Start Up Procedures

CAUTION! To prevent damage to the compressor, ensure that all refrigerant valves are open before starting the unit. Do not use untreated or improperly treated water. Equipment damage may occur.

Temporary Shutdown and Restart

Temporary Shutdown is used for control operation, maintenance or to repair the unit typically less than one week.

To shut the unit down for a short time, use the following procedure:

1. Press the STOP key on the TD7. The compressors will stop when the compressor contactors de-energize.
2. Stop the water circulation by turning off the chilled water pump at least one minute after the stop of the compressors.

To restart the unit after a temporary shutdown, enable the chilled water pump and press the AUTO key.

The unit will start normally, provided the following conditions exist:

- The Tracer™ UC800/Symbio800 receives a call for cooling and the differential-to-start is above the set point.
- All system operating interlocks and safety circuits are satisfied.

CAUTION! Under freezing conditions, the chilled water pump must remain in operation during the full shutdown period of the chiller if the chilled water loop does not contain glycol, to prevent any risk of evaporator freeze-up.

Extended Shutdown Procedure

The following procedure is to be followed if the system is to be taken out of service for an extended period of time (i.e. seasonal shutdown):

1. Test the unit for refrigerant leaks and repair as necessary.
2. Open the electrical disconnect switches for the chilled water pump. Lock the switches in the "OPEN" position.
3. Close all chilled water supply valves. Drain the water from the evaporator.
4. Open the unit main electrical disconnect and unit-mounted disconnect (if installed) and lock in the "OPEN" position.

5. At least every three months (quarterly), check the refrigerant pressure in the unit to verify the refrigerant charge integrity.

CAUTION! Lock the chilled water pump disconnects open to prevent pump damage. Lock the disconnect switch in the "OPEN" position to prevent accidental startup and damage to the system when it has been set up for extended shutdown.

During an extended shutdown period, especially over the winter season, the evaporator must be drained of water, if the chilled water loop does not contain glycol, to prevent any risk of evaporator freeze-up.

Periodic Maintenance

General

Perform all maintenance procedures and inspections at the recommended intervals. This will increase the life of the chiller and minimize the possibility of serious and costly breakdown. Use an "Operator's Log" to record the unit's operating history. The log serves as a valuable diagnostic tool for service personnel. By observing trends in operating conditions, an operator can anticipate and prevent problem situations before they occur. If the unit is not operating properly during maintenance inspections, consult the "Diagnostic and Troubleshooting" section of this manual. Proper servicing of the service valves is required. Use a backup wrench as shown in Figure when loosening or tightening the service valve cap.

Figure 28 – Servicing of service valves

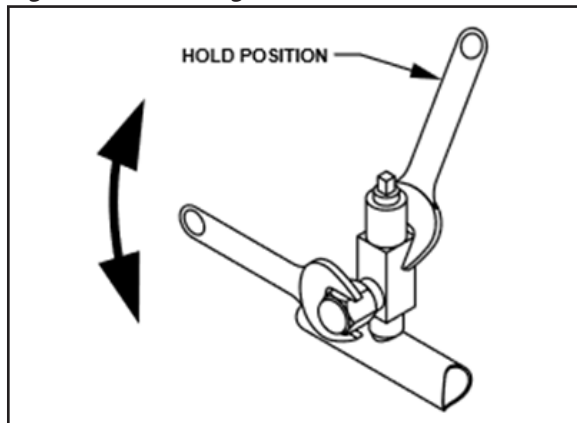

Weekly Maintenance

After the unit has been operating for approximately 30 minutes and the system has stabilized, check the operating conditions and complete the procedures below:

1. Check on the TD7 pressure for evaporator, condenser, and intermediate oil.
Note: Pressures are referenced at sea level.
2. Inspect the entire system for unusual conditions and inspect the condenser coils for dirt and debris. If the coils are dirty, refer to coil cleaning.

Check the electronic expansion valve sight glasses.

Note: The electronic expansion valve is commanded closed at unit shutdown and if the unit is off, there will be no refrigerant flow through the sight glasses. Only when a circuit is running will refrigerant flow be present.

The refrigerant flow through the sight glasses should be clear. Bubbles in the refrigerant indicate either low refrigerant charge or excessive pressure drop in the liquid line. A restriction in the line can sometimes be identified by a noticeable temperature differential between the two sides of

the restriction. Frost may often form on the liquid line at this point. Correct refrigerant charges is shown in nameplate.

NOTICE: A clear sight glass alone does not mean that the system is properly charged. Also check the system superheat, sub cooling and unit operating pressures.

NOTICE: Use only manifold gauge sets designed for use with R410A refrigerant.

Use only recovery units and cylinders designed for the higher pressure of R410A refrigerant and POE oil.

NOTICE: R410A must be charged in a liquid state.

Check the system superheat, subcooling, evaporator temperature drop (Delta-T), evaporator water flow, evaporator approach temperature, compressor discharge superheat, and compressor RLA. Normal operating conditions at ISO conditions are:

Evaporator pressure: 8bars (R410A), 7.6bars (R454B)

Evaporator Approach: 3-5°C

Evaporator Superheat: 6-7°C

Note: In Case of Optional Service valve with CXAF, ensure the re-opening of the oil return valve (Item 13 in Refrigerant system schematic & Oil lube circuit schematic for CXAF – BPHE) after refrigerant transfer.

Note: If the superheat is unstable, check the suction temperature sensor. The suction temperature sensor should be well inserted into the well and thermal grease should be used to ensure a good contact between the sensor and the well.

Electronic Expansion Valve: 30-50 percent open

Evaporator Temperature Drop (Delta-T): 5°C

Condensing Pressure: 28-32bars (R410A)

26.5-30.5bars (R454B) Condensing Approach

Temperature: 14-18°C System Subcooling: 8-12°C

(R410A) 6-10°C (R454B) If operating pressures

and sight glass conditions seem to indicate

a refrigerant shortage, measure the system

superheat and sub cooling.

Refer to "System Superheat" and "System Sub cooling." If operating conditions indicate a refrigerant overcharge, remove refrigerant at the liquid line service valve.

Allow refrigerant to escape slowly to minimize oil loss. Use a refrigerant recovery cylinder and do not discharge refrigerant into the atmosphere.

WARNING! Do not allow refrigerant to directly contact skin as injury from frostbite may result.



Periodic Maintenance

Monthly Maintenance

1. Perform all weekly maintenance procedures.
2. Manually rotate the condenser fans to ensure that there is proper clearance on the fan shroud openings.
3. Check water pump (option): Manually rotate the pump. Remove plastic plug located at the bottom of the motor frame to drain any condensation which can occur in the motor.
4. Check and clean air filter of the control panel (option).
5. In case of Twin-pump, make sure there is no pump motor fault.
Note: pump operation will be alternated at each new request of water flow or when a pump fault is detected.
WARNING! Position all electrical disconnects in the "OPEN" position and lock them to prevent injury or death due to electrical shock or moving parts. When electrical panels are ventilated, you need to change the fan filter.
6. Make any repairs necessary.

Annual Maintenance

1. Perform all weekly and monthly procedures.
2. Check the oil sump oil level and refrigerant charge while the unit is OFF.

Note: Routine changing of the oil is not required. Make an oil analysis to determine the condition of the oil.

1. Have Trane or another qualified laboratory perform a compressor oil analysis to determine system moisture content and acid level. This analysis is a valuable diagnostic tool.
2. Contact a qualified service organization to leak-test the chiller, to check operating and safety controls, and to inspect electrical components for deficiencies.
3. Inspect all piping components for leakage and damage.
4. Clean all water strainers.
Notice: If the CGAF chiller / CXAF Heat pump evaporator is drained of water, the freeze protection heater must be de-energized. Failure to de-energize the heater might cause it to burn out.
5. Clean and repaint any areas that show signs of corrosion.
6. Clean the condenser coils.
7. Check and tighten all electrical connections as necessary.

CAUTION! A clear sight glass alone does not mean that the system is properly charged. Also check the rest of the system operating conditions.

WARNING! Position all electrical disconnects in the "Open" position and lock them to prevent injury or death due to electrical shock. Clean the condenser fans. Check the fan assemblies for proper clearance in the fan shroud openings and for motor shaft misalignment or abnormal end-play, vibration and noise.

Refrigerant Emission Control

Conservation and emission reduction can be accomplished by following recommended Trane operation, maintenance, and service procedures, with specific attention to the following:

1. Refrigerant used in any type of air-conditioning or refrigerating equipment should be recovered and/or recycled for reuse, reprocessed (reclaimed). Never release refrigerant into the atmosphere.
2. Always determine possible recycle or reclaim requirements of the recovered refrigerant before beginning recovery by any method.
3. Use approved containment vessels and safety standards. Comply with all applicable transportation standards when shipping refrigerant containers.
4. To minimize emissions while recovering refrigerant, use recycling equipment. Always attempt to use methods that will pull the lowest possible vacuum while recovering and condensing refrigerant into containment.
5. Refrigerant-system cleanup methods that use filters and dryers are preferred. Do not use solvents that have ozone depletion factors. Properly dispose of used materials.
6. Take extra care to properly maintain all service equipment that directly supports refrigeration service work, such as gauges, hoses, vacuum pumps, and recycling equipment.
7. Stay aware of unit enhancements, conversion refrigerants, compatible parts, and manufacturer's recommendations that will reduce refrigerant emissions and increase equipment operating efficiencies. Follow the manufacturer's specific guidelines for conversion of existing system.
8. In order to assist in reducing power-generation emissions, always attempt to improve equipment performances with improved maintenance and operations that will help conserve energy resources.



Periodic Maintenance

Refrigerant and Oil-charge Management

Proper oil and refrigerant charge is essential for proper unit operation, unit performances, and environmental protection. Only trained and licensed service personnel should service the chiller.

Some of the symptoms of a refrigerant under-charged unit:

- Larger-than-normal evaporator approach temperatures (leaving water temperature – saturated evaporator temperature). If the refrigerant charge is correct the approach temperature is 4°C. These values are given for units running at full load and with water without antifreeze
- Low Evaporator-refrigerant temperature limit
- Low Refrigerant-Temperature cutout diagnostic
- Fully-open expansion valve
- Possible whistling sound coming from liquid line (due to high vapour velocity)
- High condenser + Sub cooler pressure drop

Some of the symptoms of a refrigerant over-charged unit

- Condenser Pressure Limit
- High –Pressure Cutout diagnostic
- More-than-normal number of fans running
- Erratic fan control
- Higher-than-normal compressor power

Some of the symptoms of an oil over-charged unit

- Larger-than-normal evaporator approach temperatures (Leaving-water-temperature – Saturated Evaporator Temperature)
- Low Evaporator-refrigerant Temperature limit
- Low Refrigerant –Temperature Cutout diagnostic
- Low unit capacity
- High oil-sump level after normal shutdown
- Discharge temperature is lower than prediction provided by compressor manufacturer selection program.

Some of the symptoms of an oil under-charged unit

- Seized or Welded compressors
- Low oil-sump level after normal shutdown

Compressor Service Information

Compressor Electrical Connections

It is very important that DSH compressors used in Trane Model CGAF chillers and CXAF Heat Pumps are wired correctly for proper rotation. These compressors will not tolerate reverse rotation. Verify correct rotation/phasing using a rotation meter.

Proper phasing is clockwise, A-B-C. If wired incorrectly a DSH compressor will make excessive noise, will not pump and will draw about half the normal current. It will also become very hot if allowed to run for an extended period.

Notice: Do not “bump” the compressor to check rotation as incorrect rotation could cause compressor motor failure in as little as 4 to 5 seconds!

Oil Level

To check compressor oil level, refer to the label near the compressor sight glass. The compressor(s) must be off. Wait three minutes. With tandem or triple compressors the oil level will equalize after shutdown. Compressor oil level should be no lower than the bottom of the sight glass and no more than a full sight glass. When operating, each compressor in a tandem or trio set may have a different oil level. The oil level may not be in the sight glass, but it must be visible through the sight glass.

Oil Fill, Removal and Capacity

The Model DSH compressors have an oil charging valve with a dip tube that goes to the bottom of the compressor. This can be used to add or remove oil from the compressor.

Care must be taken to prevent moisture from entering the systems when adding oil. Note that the POE oil used in this product is very hygroscopic and easily absorbs and retains moisture. Moisture is very difficult to remove from oil using vacuum. Also note that once the seal on a container of POE oil is opened, the oil must be used.

Use only Trane OIL0057 (3.8 l) or OIL00058E (18.9 l). These are the same oil but different container size. Do not use any other POE oil.

NOTE: Never reuse oil.

Oil Testing

We recommend performing a complete oil analysis at least once a year with the Trane laboratory specifically dedicated to oil analysis for Trane equipment. It provides an in-depth view of both compressor and refrigerant circuit conditions including presence of water, wear particles, viscosity, acidity or dielectric data. If unacceptable wear conditions develop, a change in the characteristics of the oil will be evident. Minor problems can be detected and repaired before they become major problems.

Oil Equalizer Line

DSH Compressors

The oil equalizer line is equipped with a Rotolock fitting for easy removal. Torque value for tightening these fitting is 145 N.m. Recover the system refrigerant charge and Drain the oil to a level below the oil equalizer tube fitting before removing the oil equalizer line. This must be done on both compressors. Use the oil drain valve on the compressor. If the oil is drained below the level of the oil level sight glass, it will be below the oil equalizer line level. Pressurize the low side of the compressor using nitrogen to help drain the oil. No more than 70 kPa of pressure will be needed.

Tandem and Triple Compressor Suction Restrictors

Since most tandem and triple compressor sets use unequal size compressors, these combinations require the use of a restrictor in the suction line of one or more compressors in order to provide correct oil level balance between compressors when they are operating.

Compressor Replacement

If the CGAF chiller / CXAF Heat Pump suffers a failed compressor, use these steps for replacement:

Each compressor has lifting eyes. Both lifting eyes must be used to lift the failed compressor. **DO NOT LIFT A COMPRESSOR USING A SINGLE LIFTING EYE.** Use proper lifting techniques, a spreader bar and rigging as for lifting both compressors simultaneously.

After a mechanical failure of a compressor, it is necessary to change the oil in the remaining compressor and also replace the liquid line filter drier. After an electrical failure of a compressor, it will also be necessary to change the oil in the



Compressor Service Information

remaining compressor, replace the liquid line filter drier and add a suction filter drier with clean-up cores.

Note: Do not alter the refrigerant piping in any way as this can affect compressor lubrication.

Refrigerant System Open Time

Model CGAF chillers / CXAF Heat Pump use POE oil and therefore refrigerant system open time must be kept to a minimum. The following procedure is recommended:

- Leave a new compressor sealed until it is ready to be installed in the unit. Maximum system open time is dependent upon ambient conditions, but do not exceed one hour open time.
- Plug the open refrigerant line to minimize moisture absorption. Always change the liquid line filter drier.
- Evacuate the system to 500 microns or below.
- Do not leave POE oil containers open to the atmosphere. Always keep them sealed.

Mechanical Compressor Failure

Replace the failed compressor(s) and change the oil in the remaining compressor(s) along with the refrigerant system liquid line filter drier.

Electrical Compressor Failure

Replace the failed compressor and change the oil in the other compressor(s). Also add a suction filter with cleanup cores and change the liquid line filter drier. Change filters and oil until the oil no longer test acidic. See "Oil Testing."

Compressor Motor Megging

Motor megging determines the electrical integrity of the compressor motor winding insulation. Use a 500 volt megger. A less than 1 meg-ohm reading is acceptable and 1000 ohms per nameplate volts is required to safely start the compressor.

Compressor Current Imbalance

Normal current imbalance could be 4 to 15 percent with balanced voltage due to motor design. Each phase should register 0.3 to 1.0 ohms and each phase should be within 7 percent of the other two phases. Phase to ground resistance must be infinity.

NOTICE: Maximum allowable voltage imbalance is 2 percent.

Compressor Electrical Terminal Box

Be sure to protect the terminal box when unbrazing or brazing compressor refrigerant piping connections.

Compressor Crankcase Heaters

Compressor crankcase heaters must be energized at least eight hours before starting the CGAF / CXAF chiller. This is required to boil refrigerant out of the oil before startup. Ambient temperature (except 20°C and above) is not a factor and the crankcase heaters must always be energized prior to startup.

Refrigerant Piping

The compressor suction and discharge connections and piping are copper clad steel for easy brazing. In most instances, piping may be reused. If piping is not reusable, order the correct service parts. Cut all tubing with a tubing cutter to prevent copper filings from entering the system. Cut the tubing in a straight length of pipe after the compressor connection has been unsweated. The line can then be reinstalled using a slip coupling and brazing.

Notice: The compressor suction line configuration must not be changed in any way. Changing compressor suction line configuration will compromise proper oil return to the compressor(s).

Condenser Coils MCHE Maintenance

Cleaning Procedures

It is mandatory to clean regularly the coils for a proper unit operation. Eliminate pollution and other residual material help to extend the life of the coils and the unit

CAUTION! Equipment Damage! Do not use coil cleaning agents to clean uncoated CGAF / CXAF coils. Use clean water only. Use of coil cleaning agents on uncoated CGAF / CXAF coils could cause damage to coils.

Regular coil maintenance, including frequent cleaning- enhances the unit's operating efficiency by minimizing compressor head pressure and amperage draw. The condenser coil (non-coated and e-coated) should be cleaned at least once each quarter or more if the unit is located in a "dirty" or corrosive environment. Cleaning with cleansers or detergents is strongly discouraged due to the all-aluminium construction; straight water should prove sufficient. Any breach in the tubes can result in refrigerant leaks.

Important: Only in extreme cases should any type of chemical cleaner or detergent be used on micro channel coils. If it becomes absolutely necessary because water alone did not clean the coil, specify a cleaner that is:

- A is pH neutral cleaner.
- An alkaline cleaner that is no higher than 8 on the pH scale.
- An acidic cleaner that is no lower than 6 on the pH scale.
- Does not contain any hydrofluoric acids.

Be sure to follow the instructions provided with any cleaner chosen. Keep in mind that it is still **MANDATORY** that the coils are thoroughly rinsed with water after the application of the cleaner even if the instructions specify a "No Rinse" cleaner. Cleaners or detergents that are left on the coil due to improper rinsing will significantly increase the possibility of corrosion damage on the micro channel coil.

Note: Quarterly cleaning (or more for harsh environment) is essential to extend the life of a MCHE coil and is required to maintain warranty coverage. Failure to clean a MCHE coil will void the warranty and may result in reduced efficiency and durability in the environment.

WARNING! Hazardous Voltage! Disconnect all electric power, including remote disconnects before servicing. Follow proper lockout/ tagout procedures to ensure the power cannot be inadvertently energized. Failure to disconnect power before servicing could result in death or serious injury.

1. Disconnect Power to the unit.
2. Wear proper personal protection equipment such as a face shield, gloves and waterproof clothing.
3. Remove enough panels from the unit to gain safe access to the microchannel coil.

Note: It is better to clean the coil from the opposite direction of normal air flow (inside of unit out) because this allows the debris to be pushed out rather than forced further into the coil.

1. Use a soft brush or vacuum to remove base debris or surface loaded fibers from both sides of the coil.

Note: Remove solid residue is essential to preserve performance of the coil and avoid corrosion over the length of the product life.

2. Using a sprayer and water ONLY, clean the coil following the guidelines below.
 - a. Sprayer nozzle pressure should not exceed 40 bars.
 - b. The maximum source angle should not exceed 25 degrees (Figure 22) to the face of the coil. For best results spray the micro channel perpendicular to face of the coil.
 - c. Spray nozzle should be approximately 5 to 10 cm from the coil surface.
 - d. Use at least a 15° fan type of spray nozzle.

Figure 29 – Sprayer source angle

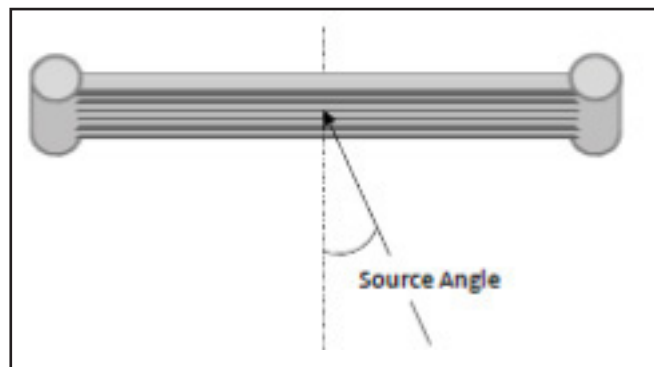

To avoid damage from the spray wand contacting the coil, make sure the 90° attachment does not come in contact with the tube and fin as abrasion to the coil could result.



Condenser Coils MCHE Maintenance

Maintenance of Flanges Connection

It is mandatory to apply marine grease all around the coil flange connections to the piping on a regular basis (for instance twice a year) to avoid traps of moisture and dirt in the gasket recess.

Repair / Replacement of Microchannel Coil

Microchannel coils are considerably more robust in design than tube and fin condenser coils, however they are not indestructible. When damage or a leak occurs in the field, it is possible to temporarily repair the coil until another coil can be ordered.

If the leak is found to be within the tube area of the coil, a field repair kit (KIT16112) is available through your local Trane parts center. Because of the all-aluminium construction and aluminium's high thermal expansion rate, a leak located at or on the header assembly cannot be repaired.

Integrated Pump Maintenance

Water Pump Maintenance

WARNING! Before starting work on the pump, make sure that the power supply has been switched off and that it cannot be accidentally switched on.

CAUTION! The lifting eyebolts of the motor are suitable for the weight of the motor only. It is not allowed to carry the complete pump on the lifting eyebolts of the motor.

It is important to keep the motor clean in order to ensure adequate cooling of the motor. If the pump is installed in dusty environments, it must be cleaned and checked regularly. Take the enclosure class of the motor into account when cleaning.

If the water loop must be emptied during period of frost, the pump has to be drained to avoid damage. Remove the filling and drain plugs. Do not re-fit the plugs until the pump is taken into operation again.

Lubrication

The bearings of motors 5.5kW and 7.5kW are greased for life and require no lubrication. Increasing bearing noise and undue vibration indicate a worn bearing. The bearing or the complete motor then needs replacement.

The bearing of motors 11kW and up must be greased every 4000 hours or at yearly service. The required grease quantity is 10g per bearing. The motor must run during lubrication. Use lithium-based grease.

The pump shaft seal does not require any special maintenance. Visual leakage check are however required. Distinctly visible leakage will require an exchange of the seal.

For further details about pump maintenance please consult the pump supplier website.

Figure 30 – Motor bearings

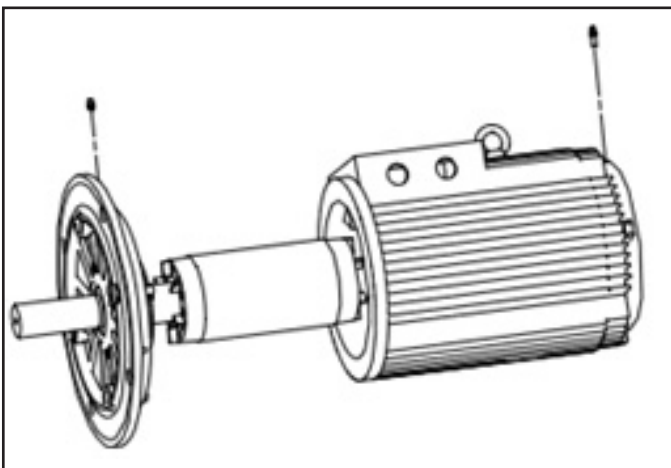



BPHE Evaporator Maintenance

BPHE Evaporator Maintenance

The Trane Model CGAF / CXAF chiller and Heat Pump uses a brazed plate heat exchanger (BPHE) (or) a Shell & tube evaporator with factory installed flow switch that is positioned in the evaporator water pipe. The evaporator inlet also includes a water strainer that must be kept in place to keep debris out of the evaporator.

Note: Strainer maintenance is critical to proper operation and reliability. Any particles larger than 1.6 mm entering the BPHE evaporator may cause the evaporator to fail, requiring replacement.

Acceptable BPHE evaporator water flow rate is 1.4 to 4.2 l/min per nominal unit kW capacity. To maintain 12-7°C in/out chilled water temperatures, the nominal water flow rate is 2.8 l/min per cooling kW.

Minimum water flow rate must be maintained to avoid laminar flow, potential evaporator freezing, scaling and poor temperature control.

Maximum water flow is 6 m/s. Flow rates greater than this will cause excessive erosion.

The BPHE evaporator is difficult to clean should it become plugged with debris. Indications of a plugged BPHE evaporator include "wet" suction due to lack of heat exchange, loss of superheat control, discharge superheat less than 35°C, compressor oil dilution and/or starvation and premature compressor failure.

BPHE Evaporator replacement

If the CGAF / CXAF BPHE evaporator requires replacement, it is very important that the new evaporator be replaced correctly and with the correct refrigerant and water piping connections. The refrigerant inlet/ liquid connection is at the bottom of the evaporator and the refrigerant outlet/ suction connection is at the top of the evaporator and both are on the same side. Pay particular attention to evaporators with dual circuits. Avoid cross-circuiting when installing the new evaporator.



Log Check Sheet

The operator log sheet are included for use as appropriate, for installation completion verification before Trane Start-up is scheduled, and for reference during the Trane Start-up.

Operator Log				
Sintesis CGAF chiller with Tracer™UC800/Symbio800 Controller - Tracer AdaptiView Reports - Log Sheet				
	Start	15 minutes	30 minutes	1 hour
Evaporator				
Active Chilled Water Setpoint				
Entering Water Temperature				
Leaving Water Temperature				
Ckt 1				
Saturated Refrigerant Temperature (°C)				
Refrigerant Pressure (kPa)				
Approach Temperature (°C)				
Water flow Status				
EXV % Open				
Ckt 2				
Saturated Refrigerant Temperature (°C)				
Refrigerant Pressure (psia)				
Approach Temperature (°C)				
Water flow Status				
EXV % Open				
Condenser				
Outdoor Temperature				
Ckt 1				
Air flow (%)				
Saturated Refrigerant Temperature (°C)				
Refrigerant Pressure (kPa)				
Sub cooling in °C				
Ckt 2				
Air flow (%)				
Saturated Refrigerant Temperature (°C)				
Refrigerant Pressure (kPa)				
Sub cooling in °C				
Compressor 1A				
Running Status				
Starts				
Running Time (Hr:min)				
Oil Pressure (kPa)				
Compressor 1B				
Running Status				
Starts				
Running Time (Hr:min)				
Oil Pressure (kPa)				
Compressor 2A				
Running Status				
Starts				
Running Time (Hr:min)				
Oil Pressure (psia)				
Compressor 2B				
Running Status				
Starts				
Running Time (Hr:min)				
Oil Pressure (psia)				
Compressor 3A				
Running Status				
Starts				
Running Time (Hr:min)				
Oil Pressure (psia)				
Compressor 3B				
Running Status				
Starts				
Running Time (Hr:min)				
Oil Pressure (psia)				
Date:				
Technician:				
Owner:				



Recommended Service Routine Frequencies

As a commitment to our customers, we have created a wide service network staffed with experienced factory-authorized technicians. At Trane we offer all the benefits of after sales service direct from the manufacturer and we are committed to our mission statement to provide efficient customer care. We would be delighted to discuss your individual requirement with you. For further information regarding Trane maintenance agreements please contact your local Trane sales office.

Year	Commis- sioning	Inspec- tion visit	Seasonal shut down	Seasonal start up	Oil analysis (2)	Vibration analysis (3)	Annual mainte- nance	Preven- tive mainte- nance	Tube analysis (1)	Com- pressor R'newal (4)
1	x	x	x	x		x		xx		
2			x	x	x		x	xxx		
3			x	x	x		x	xxx		
4			x	x	x		x	xxx		
5			x	x	x	x	x	xxx	x	
6			x	x	x	x	x	xxx		
7			x	x	x	x	x	xxx		
8			x	x	x	x	x	xxx		
9			x	x	x	x	x	xxx		
10			x	x	x	x	x	xxx	x	
over 10			every year	every year	every year (2)	x	every year	3 every year	every 3 years	40000 h

This timetable is applicable to units operating in normal conditions with an average of 4000 hours per year. If operating conditions are abnormally severe, an individual timetable must be made for that unit.

- (1) Tube testing required if aggressive water conditions exist. Applies to condensers only on water cooled units.
- (2) Schedule as per previous analysis result or at least once a year.
- (3) Year 1 to define equipment baseline. Subsequent year based on oil analysis results or schedule as per vibration analysis.
- (4) Recommended at 40 000 run hours or 100 000 equivalent operating hours whichever comes first. Schedule also depends on results from oil analysis / vibration analysis.

Seasonal start up and shutdown are mainly recommended for comfort air conditioning. Annual and preventive maintenance are mainly recommended for Process applications.

Additional Services

Oil Analysis

Trane Oil Analysis is a predictive tool used to detect minor issues before they become major problems. It also reduces failure detection time and allows planning for appropriate maintenance. Oil changes can be reduced by half resulting in lower operating costs and a lower impact on the environment.

Vibration Analysis

Vibration analysis is required when oil analysis reveals the presence of wear indicating the start of possible bearing or motor failure. Trane oil analysis has the ability to identify the type of metallic particles in the oil which, when combined with the vibration analysis, will clearly point out the failing components.

Vibration analysis should be performed on a regular basis to build a vibration trend of the equipment and avoid unplanned downtime and costs.

System Upgrade

This Service provides a consulting service. Upgrading your equipment will increase the unit reliability and can reduce the operating costs by optimizing the controls. A list of solutions / recommendations to the system will be explained to the customer. Actual upgrade for the system will be costed separately.

Water Treatment

This Service provides all of the necessary chemicals to properly treat each water system for the period designated.

The inspections will be conducted at agreed upon intervals and Trane Service First will submit a written report to the customer after each inspection.

These reports will indicate any corrosion, scaling, and alga growth in the system.

Refrigerant Analysis

This Service includes a thorough analysis for contamination and solution upgrade.

It is recommended that this analysis be performed every six months.

Annual Cooling Tower Maintenance

This Service includes the inspection and maintenance of the cooling tower at least once a year.

This involves checking the motor.

24 Hours Duty

This service includes emergency calls outside of the office normal working hours.

This Service is only available with a Maintenance Contract, where available.

Trane Select Agreements

Trane Select Agreements are programs tailored to your needs, your business and your application. They offer four different levels of coverage. From preventive maintenance plans to fully comprehensive solutions, you have the option of selecting the coverage that best suits your requirements.

5 Years Motor-Compressor Warranty

This Service will provide a 5 years part and labor warranty for the motor compressor only.

This Service is only available for units covered by a 5 years Maintenance Contract.

Tube Analysis (Shell & Tube)

- Eddy Current Tube Testing for prediction of tube failure/ wear
- Frequency - every 5 years for first 10 years (depending on the water quality), then every 3 years thereafter.

Energy Enhancement

With Trane Building Advantage you can now explore cost effective ways to optimise the energy efficiency of your existing system and generate immediate savings. Energy management solutions are not only for new systems or buildings. Trane Building Advantage offers solutions designed to unlock energy savings in your existing system.

Trane - by Trane Technologies (NYSE:TT), a global climate innovator - creates comfortable, energy efficient indoor environments for commercial and residential applications. For more information, please visit trane.com or tranetechnologies.com.

Trane has a policy of continuous product and product data improvement and reserves the right to change design and specifications without notice. We are committed to using environmentally conscious print practices.

CG-SVX039E-GB June 2023
Supersedes CG-SVX039D-GB (April 2022)

© 2023 Trane

Confidential and proprietary Trane information