



Installation Operation Maintenance

XSTREAM

EXCELLENT

**GVWF XSE G - GVWF G (R1234ze-R515B)
GVWF (R134a/R513A)
High Speed Centrifugal Chiller
350 - 2530 kW**





Contents

Introduction	3
Unit model number description.....	5
Unit Description.....	7
Installation - Mechanical.....	9
Installation - Electrical.....	20
Operating Principles Mechanical.....	25
Operating map.....	26
Controls/Tracer TD7 Operator Interface.....	28
Pre-Start Checkout	29
Unit Start-up.....	30
Periodic Maintenance.....	31
Maintenance Procedures	33
Recommended service routine frequencies.....	34
Additional services	35

Introduction

Foreword

These instructions are given as a guide to good practice in the installation, start-up, operation, and maintenance by the user, of Trane XStream Excellent chillers GVWF, manufactured in France. A separate manual is available for the use and maintenance of the unit's control, Symbio™ 800. They do not contain full service procedures necessary for the continued successful operation of this equipment. The services of a qualified technician should be employed through the medium of a maintenance contract with a reputable service company. Read this manual thoroughly before unit start-up. Units are assembled, pressure tested, dehydrated, charged and tested in accordance with factory standard before shipment.

Warnings and Cautions

Warnings and Cautions appear at appropriate sections throughout this manual. Your personal safety and the proper operation of this machine require that you follow them carefully. The constructor assumes no liability for installations or servicing performed by unqualified personnel.

WARNING: Indicates a potentially hazardous situation which, if not avoided, could result in death or serious injury.

CAUTION: Indicates a potentially hazardous situation which, if not avoided, may result in minor or moderate injury. It may also be used to alert against unsafe practices or for equipment or property-damage-only accidents.

Safety Recommendations

To avoid death, injury, equipment or property damage, the following recommendations should be observed during maintenance and service visits:

1. The maximum allowable pressures for system leak testing on low and high pressure side are given in the chapter "Installation". Insure to do not exceed test pressure by using appropriate device.
2. Disconnect all power supplies before any servicing on the unit.
3. Service work on the refrigeration system and the electrical system should be carried out only by qualified and experienced personnel.
4. To avoid any risk, it is recommended to place the unit on an area with restricted access.

Reception

On arrival, inspect the unit before signing the delivery note. Specify any visible damage on the delivery note, and send a registered letter of protest to the last carrier of the goods within 7 days of delivery.

Notify the local TRANE sales office at the same time. The delivery note must be clearly signed and countersigned by the driver.

Any concealed damage shall be notified by a registered letter of protest to the last carrier of the goods within 7 days of delivery. Notify the local TRANE sales office at the same time.

Important notice: No shipping claims will be accepted by TRANE if the above mentioned procedure is not respected.

For more information, refer to the general sales conditions of your local TRANE sales office.

Note: Unit inspection in France. Delay to send registered letter in case of visible and concealed damage is only 72 hours.

Loose Parts Inventory

Check all the accessories and loose parts that are shipped with the unit against the shipping list. Included in these items will be the water vessel drain plugs Water Flow Switch (optional), rigging and electrical diagrams, service literature, which are placed inside the control panel and/or starter panel for shipment.

If optional elastomeric isolators are ordered with the unit (model number digit 49 =1) they are shipped mounted on the horizontal support frame of the chiller. The isolators' location and distribution weight diagram is placed with the service literature inside the starter/ control panel.

Warranty

Warranty is based on the general terms and conditions of the manufacturer. The warranty is void if the equipment is repaired or modified without the written approval of the manufacturer, if the operating limits are exceeded or if the control system or the electrical wiring is modified. Damage due to misuse, lack of maintenance or failure to comply with the manufacturer's instructions or recommendations is not covered by the warranty obligation. If the user does not conform to the rules of this manual, it may entail cancellation of warranty and liabilities by the manufacturer.



Introduction

Unit Description

The XStream Excellent GVWF units are high speed centrifugal compressor type, water-cooled, liquid chillers, designed for installation indoors. According to capacity, units have either one circuit with one compressor for sizes 115 & 140 XSE G and two circuits with 2, 3 or 4 compressors for all other sizes. The GVWF units are packaged with an evaporator and condenser.

Note: Each GVWF unit is a completely assembled package that is factory-piped, wired, leak tested, dehydrated, charged and tested for proper control operations prior to shipment. The chilled water inlet and outlet openings are covered for shipment.

The GVWF series features Trane's exclusive Adaptive Control logic with Symbio 800™ controls. It monitors the control variables that govern the operation of the chiller unit. Adaptive Control logic can correct these variables, when necessary, to optimize operational efficiencies, avoid chiller shutdown, and keep producing chilled water.

Each refrigerant circuit is provided with filter, sight glass, electronic expansion valve, and charging valves.

The shell-and-tube CHIL™ (Compact-High performance-Integrated design-Low charge) evaporator and condenser are manufactured in accordance with Pressure Equipment Directive (PED) standards. The evaporator is insulated according the option ordered. Both evaporator and condenser are equipped with water drain and vent connections.

Units are generally shipped with refrigerant charge.

Refrigerant

Consult the addendum to Manuals for units with refrigerant, for conformity to the Pressure Equipment Directive (PED) 2014/68/EU and Machinery Directive 2006/42/EC.

Maintenance contract

It is strongly recommended that you sign a maintenance contract with your local Trane Service Agency. This contract provides regular maintenance of your installation by a specialist in our equipment. Regular maintenance ensures that any malfunction is detected and corrected in good time and minimizes the possibility that serious damage will occur. Finally, regular maintenance ensures the maximum operating life of your equipment. We would remind you that failure to respect these installation and maintenance instructions may result in immediate cancellation of the warranty.

Training

To assist you in obtaining the best use of it and maintaining it in perfect operating condition over a long period of time, the manufacturer has at your disposal a refrigeration and air conditioning service school. The principal aim of this is to give operators and technicians a better knowledge of the equipment they are using, or that is under their charge. Emphasis is particularly given to the importance of periodic checks on the unit operating parameters as well as on preventive maintenance, which reduces the cost of owning the unit by avoiding serious and costly breakdown.

Unit model number description

Digit 1, 2, 3, 4 – Unit Model GVWF

Digit 5, 6, 7 – Unit size

115 XSE G = 115 Nominal Tons (R1234ze*)
 140 XSE G = 140 Nominal Tons (R1234ze*)
 230 XSE G = 230 Nominal Tons (R1234ze*)
 280 XSE G = 280 Nominal Tons (R1234ze*)
 345 XSE G = 345 Nominal Tons (R1234ze*)
 460 XSE G = 460 Nominal Tons (R1234ze*)
 540 XSE G = 540 Nominal Tons (R1234ze*)
 620 XSE G = 620 Nominal Tons (R1234ze*)
 135 = 135 Nominal Tons (R1234ze*)
 160 = 160 Nominal Tons (R1234ze*)
 185 = 185 Nominal Tons (R1234ze*)
 375 = 375 Nominal Tons (R1234ze*)
 190 = 190 Nominal Tons (R134a / R513A)
 215 = 215 Nominal Tons (R134a / R513A)
 260 = 260 Nominal Tons (R134a / R513A)
 275 = 275 Nominal Tons (R134a / R513A)
 300 = 300 Nominal Tons (R134a / R513A)
 320 = 320 Nominal Tons (R134a / R513A)
 325 = 325 Nominal Tons (R134a / R513A)
 370 = 370 Nominal Tons (R134a / R513A)
 380 = 380 Nominal Tons (R134a / R513A)
 390 = 390 Nominal Tons (R134a / R513A)
 410 = 410 Nominal Tons (R134a / R513A)
 420 = 420 Nominal Tons (R134a / R513A)
 480 = 480 Nominal Tons (R134a / R513A)
 515 = 515 Nominal Tons (R134a / R513A)
 570 = 570 Nominal Tons (R134a / R513A)
 590 = 590 Nominal Tons (R134a / R513A)
 695 = 695 Nominal Tons (R134a / R513A)
 760 = 760 Nominal Tons (R134a / R513A)
 * R1234ze units are available with R515B - please contact your Trane sales office

Digit 8 – Unit Power supply D = 400 V – 50 Hz – 3Ph

Digit 9 – Factory E = Europe

Digit 10&11 – Design Sequence - Factory assigned

Digit 12 – Not used

Digit 13 – Starter type X = Integrated VFD

Digit 14 – Agency listing C = CE marking U = UKCA marking

Digit 15 – Not used

Digit 16 – Unit Application X = Water to water - cooling application

Digit 17 – Refrigerant 1 = R134a Z = R1234ze 3 = R513A *R515B available on request. Ask your Trane sales office

Digit 18 – Sound Attenuation Package X = Without L = With

Digit 19 – Relief Valve Option

L = Single Relief Valve Condenser
 2 = Single Relief Valve Condenser & Evaporator
 D = Dual relief valve with 3 way valve condenser
 4 = Dual relief valve with 3 way valve condenser & Evaporator

Digit 20 – Not used

Digit 21 & 22 – Evaporator size

1A = Evaporator E377A
 1B = Evaporator E377B
 2C = Evaporator E517C
 3A = Evaporator E587A
 3B = Evaporator E587B
 3C = Evaporator E587C
 4A = Evaporator E337A
 6A = Evaporator 167A
 6B = Evaporator 167B
 6C = Evaporator 167C
 7A = Evaporator 207A
 8A = Evaporator 257A
 8B = Evaporator 257B
 9A = Evaporator 807A
 9B = Evaporator 807B
 9C = Evaporator 807C
 9D = Evaporator 807D
 SC = Evaporator 164C

Digit 23 – Evaporator Configuration

X = Standard tubes

Digit 24 – Evaporator Water connection

D = 2 Pass Right hand (facing front panel)
 G = 2 Pass left hand (facing front panel)
 X = Single pass standard (cross flow)
 R = Single pass Right Hand with external pipe
 L = Single pass Left Hand with external pipe

Digit 25 – Evaporator Water side Pressure

X = 10 Bar Evaporator Water Pressure

Digit 26 – Evaporator application

N = Standard Cooling (above 5°C)

Digit 27 – Cold Parts Thermal insulation

N = Standard
 X = None

Digit 28 & 29 – Condenser size

2A = Condenser C367A
 2B = Condenser C367B
 2C = Condenser C367C
 2D = Condenser C367D
 3A = Condenser C361A
 3D = Condenser C361D
 4D = Condenser C507D
 5A = Condenser C557A
 5B = Condenser C557B
 5C = Condenser C557C
 6A = Condenser C37 MJ
 6B = Condenser C37 m1
 6C = Condenser C37 m2
 7A = Condenser C57 MJ
 7B = Condenser C57 m1
 8A = Condenser C67 MJ
 9A = Condenser C807A
 9B = Condenser C807B
 9C = Condenser C807C
 R4 = Condenser C3AS4
 RJ = Condenser C3ASJ
 S4 = Condenser C5AS4
 SJ = Condenser C5ASJ



Unit model number description

Digit 30 – Condenser tubes

X = Standard tubes

Digit 31 – Condenser Water connection

D = 2 Pass Right hand (facing front panel)

G = 2 Pass left hand (facing front panel)

X = Single pass standard (cross flow)

R = Single pass Right Hand with external pipe

L = Single pass Left Hand with external pipe

Digit 32 – Not used

Digit 33 – Condenser Water side pressure

X = 10 Bar Condenser Water Pressure

Digit 34 – Condenser Thermal Insulation

X = None

H = With Condenser Insulation

Digit 35 – Not used

Digit 36 – Evaporator Pump Smart Flow control

X = None

E = VPF Constant DeltaT Evaporator

Digit 37 – Power Protection

F = Disconnect switch with fuses

B = Disconnect switch with circuit breakers

D = Dual Power Supply with circuit breakers

Digit 38 – Power losses configuration

X = None

R = Rapid Restart

U = UPS ready + Rapid Restart

Digit 39 – Human interface language

M - Multilingual

Digit 40 – Smart com protocole

X = None

B = BACnet MSTP interface

C = BACnet IP interface

M = ModBus RTU interface

L = LonTalk interface

T = ModBus TCP interface

Digit 41 – Communication customer input/output

X = None

A = External Set points & Capacity outputs – Voltage Signal

B = External Set points & Capacity outputs – Current Signal

Digit 42 – Outdoor Air Temperature Sensor

0 = No Air Outdoor Temperature Sensor

A = Outdoor Air Temperature Sensor – CWR/Low Ambient

Digit 43 – Electrical IP protection

X = Enclosure with dead front protection

1 = Enclosure with IP20 internal protection

Digit 44 – Master Slave Set

X = None

M = With Master Slave Control

Digit 45 – Energy meter

X = None

M = Included

Digit 46 – Condenser Pump Smart Flow Control/Other

Condenser Pressure Control Outputs

X = None

1 = Condenser Pressure in % HPC

2 = Differential Pressure

3 = Condenser Head Pressure Flow Control

4 = VPF Constant DeltaT Condenser Flow Control

Digit 47 – Power socket

X = None

P = Included (230V-100W)

Digit 48 – Factory test

X = None (no test)

B = Visual inspection with customer

C = Performance test with customer: 1 point

D = Performance test with customer: 2 points

E = Performance test without customer: 1 point

Digit 49 – Installation Accessory

X = None

1 = Neoprene Isolators

4 = Neoprene Pads

Digit 50 – Connection Accessory

X = Grooved pipe connection

W = Grooved pipe with coupling and pipe stub

Digit 51 – Flow switch

X = None

A = Evaporator or Condenser

B = Evaporator and Condenser

Digit 52 – Literature Language

B = Bulgarian

C = Spanish

D = German

E = English

F = French

H = Dutch

I = Italian

K = Finnish

L = Danish

M = Swedish

N = Norwegian

P = Polish

R = Russian

T = Czech

U = Greek

V = Portugese

Z = Slovene

2 = Romanian

3 = Serbian

4 = Slovak

5 = Croatian

6 = Hungarian

8 = Turkish

Digit 53 – Shipping package

X = Shrink Wrap as Standard

A = Containerization Package

Digit 54 – Base rail forklift

X = Without

B = With

Digit 55 – EXV Selection

U = Undersized EXV

L = Large EXV

Digit 56 – Design special

X = None

S = Special

Unit Description

Figure 1 – Component location for a typical GVWF unit

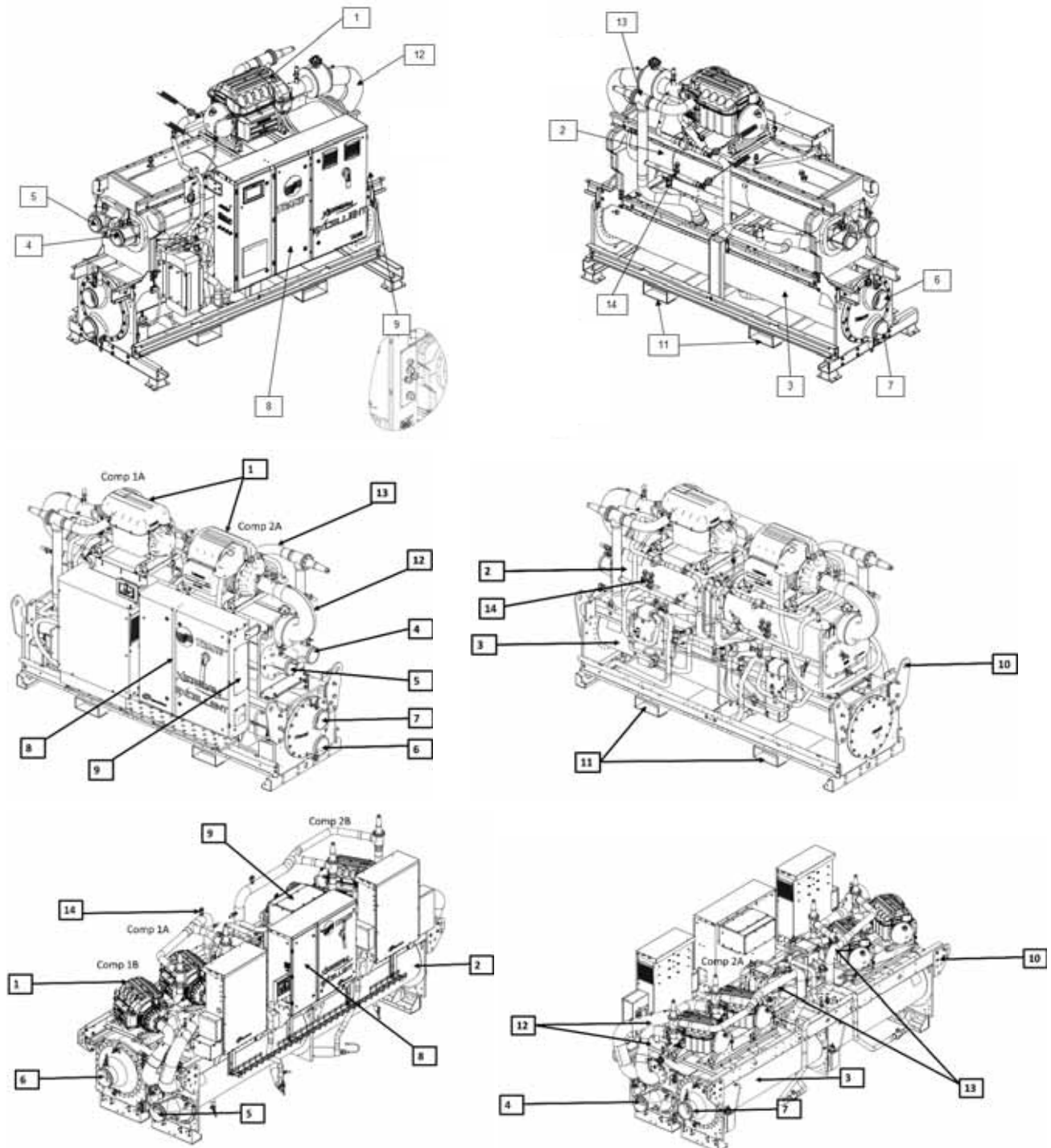

- 1 = Compressor
- 2 = Evaporator
- 3 = Condenser
- 4 = Evaporator Inlet Connection
- 5 = Evaporator Outlet connection
- 6 = Condenser Inlet Connection
- 7 = Condenser Outlet connection

- 8 = Electrical Panel
- 9 = Power cable gland plate for customer wiring
- 10 = Movable rigging eyes Ø45mm x 4
- 11 = Forklift rail 240 mm x 45 mm (x 2)
- 12 = Compressor Suction pipe
- 13 = Compressor Discharge pipe
- 14 = Valve connection Condenser



Unit Description

Installation overview and requirements.

Contractor responsibilities

A list of the contractor responsibilities typically associated with the GVWF installation process is provided in Table 1.

- Locate and maintain the loose parts. Loose parts are located in the control panel.
- Install the unit on a foundation with flat support surfaces, level within 5 mm and of sufficient strength to support concentrated loading. Place the manufacturer-supplied isolation pad assemblies under the unit.
- Install the unit per the instructions outlined in the "Mechanical Installation" section.
- Complete all water piping and electrical connections.

Note: Field piping must be arranged and supported to avoid stress on the equipment. It is strongly recommended that the piping contractor provide at least 1m of clearance between the pre-installation piping and the planned location of the unit. This will allow for proper fit-up upon arrival of the unit at the installation site. All necessary piping adjustments can be made at that time

- Where specified, supply and install valves in the water piping upstream and downstream of the evaporator and condenser water boxes, to isolate the shells for maintenance and to balance/trim the system.

- Supply and install flow switches or equivalent devices in both the chilled water and condenser water piping. Interlock each switch with the proper pump starter and Symbio™ 800, to ensure that the unit can only operate when water flow is established.
- Supply and install taps for thermometers and pressure gauges in the water piping, adjacent to the inlet and outlet connections of both the evaporator and the condenser.
- Supply and install drain valves on each water box.
- Supply and install vent cocks on each water box.
- Where specified, supply and install strainers ahead of all pumps and automatic modulating valves.
- Supply and install refrigerant pressure relief piping from the pressure relief to the atmosphere.
- Start the unit under supervision of a qualified service technician.
- Where specified, supply and insulate the evaporator and any other portion of the unit, as required, to prevent sweating under normal operating conditions.
- For unit-mounted starters, cutouts are provided at the top of the panel for line-side wiring.
- Supply and install the wire terminal lugs to the starter.
- Supply and install field wiring to the line-side lugs of the starter.

Table 1 – Installation Responsibility

Requirement	Trane supplied Trane installed	Trane supplied Field installed	Customer supplied Customer installed
Foundation			Meet foundation requirements
Rigging			Safety chains Clevis connectors Lifting beams
Isolation		Isolation pads	Other type of isolators
Electrical	- Circuit breakers or fusible disconnects (Optional) - Unit mounted starter: AFD (Adaptive Frequency Drive)	- Flow switches (may be field supplied) - Harmonic filters (on request according to customer electrical network and equipment) - Junction box on control panel	- Circuit breakers or fusible disconnect - Electrical connections to unit mounted starter (optional) - Electrical connections to remote mounted starter (optional) - Wiring sizes per submittal and local regulations - Terminal lugs - Ground connections - BAS wiring (optional) - Control voltage wiring - Chilled water pump contactor and wiring including interlock - Option relays and wiring
Water piping		Flow switches (may be field supplied)	- Taps for thermometers and gauges - Thermometers - Strainers (as required) - Water flow pressure gauges - Isolation and balancing valves in water piping - Vents and drain on waterbox valves - Pressure relief valves for water side
Insulation	Insulation		Insulation
Water piping connection components	- Grooved pipe - Return pipe to get inlet and outlet on same side (optional) - Grooved pipe to flagged connection (optional)		
Precaution on exposure to refrigerant			Respect recommendation of IOM addendum

Installation - Mechanical

Storage

If the chiller is to be stored more than one month prior to installation, observe the following precautions:

- Do not remove the protective coverings from the electrical panel.
- Store the chiller in a dry, vibration-free, secure area.
- At least every three months, attach a gauge and manually check the pressure in the refrigerant circuit. If the refrigerant pressure is below 5 bar at 21°C (3 bar at 10 °C), call a qualified service organization and the appropriate Trane sales office.

NOTE: Pressure will be approximately 1.0 bar if shipped with the optional nitrogen charge.

Noise Considerations

- Refer to Engineering Bulletin for sound consideration applications.
- Locate the unit away from sound-sensitive areas.
- Install the isolation pads under the unit. Refer to “Unit Isolation.”
- Install rubber vibration isolators in all water piping.
- Use flexible electrical conduit for final connection to the Symbio™ 800.
- Seal all wall penetrations.

NOTE: Consult an acoustical engineer for critical applications.

Foundation

Provide rigid, non-warping mounting pads or a concrete foundation of sufficient strength and mass to support the chiller operating weight (including completed piping and full operating charges of refrigerant and water).

Refer to General information for unit operating weights.

Once in place, level the chiller within 6 mm over its length and width.

The manufacturer is not responsible for equipment problems resulting from an improperly designed or constructed foundation.

Vibration Eliminators

- Provide rubber boot type isolators for all water piping at the unit.
- Provide flexible conduit for electrical connections to the unit.
- Isolate all pipe hangers and be sure they are not supported by main structure beams that could introduce vibration into occupied spaces.
- Make sure that the piping does not put additional stress on the unit.

NOTE: Do not use metal braided type eliminators on the water piping. Metal braided eliminators are not effective at the frequencies at which the unit will operate.

Clearances

Provide enough space around the unit to allow the installation and maintenance personnel unrestricted access to all service points. A minimum of 1 m is recommended for compressor service and to provide sufficient clearance for the opening of control panel doors. Refer to submittals (documents supplied in document package coming with unit) for minimum clearances required for condenser or evaporator tube service. In all cases, local codes will take precedence over these recommendations. If the room configuration requires a variance to the clearance dimensions, contact your sales representative.

NOTE: Required vertical clearance above the unit is at least 1 m. There should be no piping or conduit located over the compressor motor.

NOTE: Maximum clearances are given. Depending on the unit configuration, some units may require less clearance than others in the same category. Heat exchanger tube removal clearance is necessary for detubing and retubing.

Ventilation

The unit produces heat even though the compressor is cooled by the refrigerant. Make provisions to remove heat generated by unit operation from the equipment room. Ventilation must be adequate to maintain an ambient temperature lower than 40°C. Vent the pressure relief valves in accordance with all local and national codes. Refer to “Pressure Relief Valves”. Make provisions in the equipment room to keep the chiller from being exposed to ambient temperatures below 10°C.

Water Drainage

Locate the unit near a large capacity drain for water vessel drain-down during shutdown or repair. Condensers and evaporators are provided with drain connections. Refer to “Water Piping.” All local and national codes apply.

Unit dimensions and weights

Refer to the unit submittals for specific dimensional information (documents supplied in document package coming with unit).

Installation - Mechanical

Lifting Procedure

WARNING

Heavy Equipment!

Always use lifting equipment with a capacity exceeding unit lifting weight by an adequate safety factor. Follow the instructions given in the lifting and handling document and submittal supplied with documentation package shipped with the unit. Failure to do so can result in death personal injury.

CAUTION

Equipment Damage!

Never use a forklift to move unit unless forklift option (digit 54 = B) is available. When forklift option is not available, the skid is not designed to support the unit at any one point and using a forklift to move the equipment may cause unit damage. Always position the lifting beam so that cables do not contact the unit. Failure to do so may result in unit damage.

NOTE: If absolutely necessary, the chiller can be pushed or pulled across a smooth surface if it is bolted to wood shipping mounts.

WARNING:

Shipping Mounts!

Do not use the threaded holes in the compressor to lift or assist in lifting the unit. They are not intended for that purpose. Do not remove the wood mounts (option) until the unit is in its final location. Removal of wood shipping mounts prior to unit final locating could result in death or serious injury or equipment damage.

1. When the unit is at its final location, remove the shipping bolts that secure the unit to the wood base mounts (option).
2. Rig the unit properly and lift from above or jack the unit (alternate moving method). Use the points shown on the rigging diagram that ships with the unit. Remove the base mounts.
3. Install clevis connectors in lifting holes provided on the unit. Attach lifting chains or cables to clevis connectors. Each cable alone must be strong enough to lift the chiller.
4. Attach cables to lifting beam. Total lifting weight, lifting weight distribution and required lifting beam dimensions are shown in the rigging diagram shipped with each unit. The lifting beam crossbar must be positioned so the lifting cables do not contact unit piping or electrical panel enclosure.

NOTE: The anti-rotation strap is not a lifting chain, but a safety device to ensure that the unit cannot tilt during lifting.

Alternate Moving Method

If it is not possible to rig from above as shown in the figures, the unit may also be moved by jacking each end high enough to move an equipment dolly under each tube sheet support. Once securely mounted on the dollies, the unit may be rolled into position.

WARNING: Connect an anti-rotation strap between the lifting beam and compressor before lifting unit. Failure to do so may result in death or serious injury should a lifting cable fail.

Lifting and handling drawings are included in the document package sent with the unit.

Figure 2 – Example of spreader to be used to lift GVWF

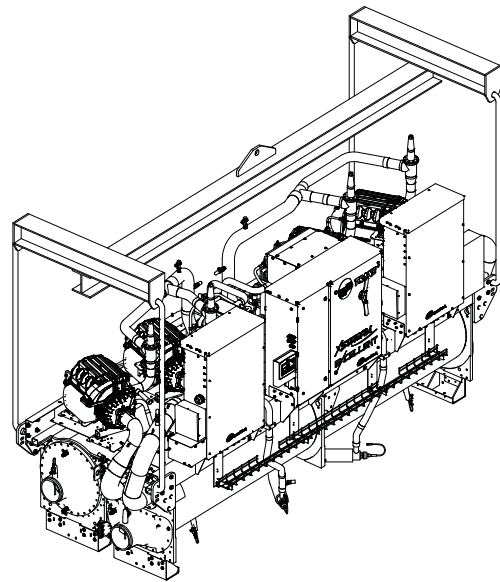

Isolation Pads

6. The elastomeric pads shipped (as standard) are adequate for most installations. For additional details on isolation practices, consult an acoustical engineer for sensitive installations. With frequency converter it is possible that some vibration frequencies can be transmitted into the foundations. This depends on the building structure. It is recommended for these situations to use neoprene isolators instead of elastomeric pads. Drawings to locate isolation pads are supplied with unit document package.
7. During final positioning of the unit, place the isolation pads under the evaporator and condenser tube sheet supports. Level the unit.
8. The unit is shipped with spacers on the compressor mount that protect the compressor isolation pads during shipping and in handling. Remove these spacers before the unit is operated.

Drawings to locate isolation pads are included with in document package sent with the unit.

Installation - Mechanical

Unit Leveling

NOTE: The electrical panel side of the unit is designated as the “front” of the unit.

1. Check unit level end-to-end by placing a level on the top surface of the evaporator shell.
2. If there is insufficient surface available on the top of the evaporator shell, attach a magnetic level to the bottom of the shell to level the unit. The unit should be level to within 5 mm over its length.
3. Place the level on the evaporator shell tube sheet support to check side-to-side (front-to-back) level. Adjust to within 5 mm of level front-to-back. **NOTE:** The evaporator **MUST** be level for optimum heat transfer and unit performance.
4. Use full-length shims to level the unit.

Water Piping

Piping Connections

To prevent equipment damage, bypass the unit if using an acidic flushing agent.

Make water piping connections to the evaporator and condenser. Isolate and support piping to prevent stress on the unit. Construct piping according to local and national codes. Insulate and flush piping before connecting to unit.

The chilled water connections to the evaporator are to be grooved-pipe type connections. Do not attempt to weld these connections, as the heat generated from welding can cause microscopic and macroscopic fractures on the cast iron waterboxes that can lead to premature failure of the waterbox. Refer to submittal for dimension of tube stub for grooved connection

To prevent damage to chilled water components, do not allow evaporator pressure (maximum working pressure) to exceed 10 bar.

Reversing Water Boxes is prohibited

Heat exchanger are one pass evaporator and condenser. It is critical to keep the factory layout for water boxes. Therefore reversing water boxes may lead to functional disorder.

NOTE: Dimensions of tube stub for grooved connection are included in submittal drawings.

Vents and Drains

Install pipe plugs in evaporator and condenser water box drain and vent connections before filling the water systems. To drain water, remove vent and drain plugs, install a NPT connector in the drain connection and connect a hose to it.

Water Treatment

WARNING: Do not use untreated or improperly treated water. Use of untreated or improperly treated water may result in equipment damage.

The following disclamatory label is provided on each GVWF unit:

The use of improperly treated or untreated water in this equipment may result in scaling, erosion, corrosion, algae or slime. The services of a qualified water treatment specialist should be engaged to determine what treatment, if any, is advisable. The warranty specifically excludes liability for corrosion, erosion or deterioration of the manufacturer’s equipment. The manufacturer assumes no responsibilities for the results of the use of untreated or improperly treated water, or saline or brackish water.



Installation - Mechanical

Evaporator Piping Components

Note: Make sure all piping components are between the shutoff valves, so that isolation can be accomplished on both the condenser and the evaporator. "Piping components" include all devices and controls used to provide proper water system operation and unit operating safety. These components and their general locations are given below.

Entering Chilled Water Piping

- Air vents (to bleed air from system)
- Water pressure gauges with shutoff valves
- Pipe unions
- Vibration eliminators (rubber boots)
- Shutoff (isolation) valves
- Thermometers
- Clean out tees
- Pipe strainer

Leaving Chilled Water Piping

- Air vents (to bleed air from system)
- Water pressure gauges with shutoff valves
- Pipe unions
- Vibration eliminators (rubber boots)
- Shutoff (isolation) valves
- Thermometers
- Clean out tees
- Balancing valve
- Pressure relief valve

To prevent evaporator damage, do not exceed 10 bar evaporator water pressure for standard water boxes.

To prevent tube damage, install a strainer in the evaporator water inlet piping.

Condenser Piping Components

"Piping components" include all devices and controls used to provide proper water system operation and unit operating safety. These components and their general locations are given below.

Entering Condenser Water Piping

- Air vents (to bleed air from system)
- Water pressure gauges with shutoff valves
- Pipe unions
- Vibration eliminators (rubber boots)
- Shutoff (isolation) valves
- One per each pass
- Thermometers
- Clean out tees
- Pipe strainer
- Flow switch

Leaving Condenser Water Piping

- Air vents (to bleed air from system)
- Water pressure gauges with shutoff valves
- Pipe unions
- Vibration eliminators (rubber boots)
- Shutoff (isolation) valve
- One per each pass
- Thermometers
- Clean out tees
- Balancing valve
- Pressure relief valve

To prevent condenser damage, do not exceed 10 bar water pressure for standard water boxes.

To prevent tube damage, install a strainer in condenser water inlet piping.

Water Pressure Gauges and Thermometers

Install field-supplied thermometers and pressure gauges (with manifolds, whenever practical). Locate pressure gauges or taps in a straight run of pipe; avoid placement near elbows, etc. Be sure to install the gauges at the same elevation on each shell if the shells have opposite-end water connections.

Water Pressure Relief Valves

Install a pressure relief valve in both evaporator and condenser water systems. Failure to do so could result in shell damage.

Install a water pressure relief valve in one of the condenser and one of the evaporator water box drain connections or on the shell side of any shutoff valve. Water vessels with close-coupled shutoff valves have a high potential for hydrostatic pressure buildup on a water temperature increase. Refer to applicable regulation for relief valve installation guidelines.

Flow Sensing Devices

Use field-provided flow switches or differential pressure switches with pump interlocks to sense system water flow. Flow switch locations are schematically shown in Figure.

To provide chiller protection, install and wire flow switches in series with the water pump interlocks, for both chilled water and condenser water circuits (refer to the "Installation Electrical" section). Specific connections and schematic wiring diagrams are shipped with the unit.

Flow switches must stop or prevent compressor operation if either system water flow drops off drastically. Follow the manufacturer's recommendations for selection and installation procedures. General guidelines for flow switch installation are outlined below.

- Mount the switch upright, with a minimum of 5 pipe diameters of straight, horizontal run on each side.
- Do not install close to elbows, orifices or valves.

Note: The arrow on the switch must point in the direction of the water flow. To prevent switch fluttering, remove all air from the water system.

Note: The Symbio™ 800 provides a 6-second time delay on the flow switch input before shutting down the unit on a loss-of-flow diagnostic. Contact a qualified service organization if nuisance machine shutdowns persist. Adjust the switch to open when water flow falls below nominal. Refer to the General Data table for minimum flow recommendations for specific water pass arrangements. Flow switch contacts are closed on proof of water flow.

Refrigerant Pressure Relief Valve Venting

To prevent injury due to inhalation of refrigerant gas, do not discharge refrigerant anywhere. If multiple chillers are installed, each unit must have separate venting for its relief valves. Consult local regulations for any special relief line requirements.

All relief valve venting is the responsibility of the installing contractor. All GVWF units use condenser pressure relief valves that must be vented to the outside of the building. Relief valve connection sizes and locations are shown in the unit submittals. Refer to national regulations for relief valve vent line sizing information.

Do not exceed vent piping code specifications. Failure to heed specifications could result in capacity reduction, unit damage and/or relief valve damage.

Note: Once opened, relief valves tend to leak.

Installation - Mechanical

GVWF Evaporator and Condenser Pressure drop

Figure 3 – GVWF Evaporator Pressure drop

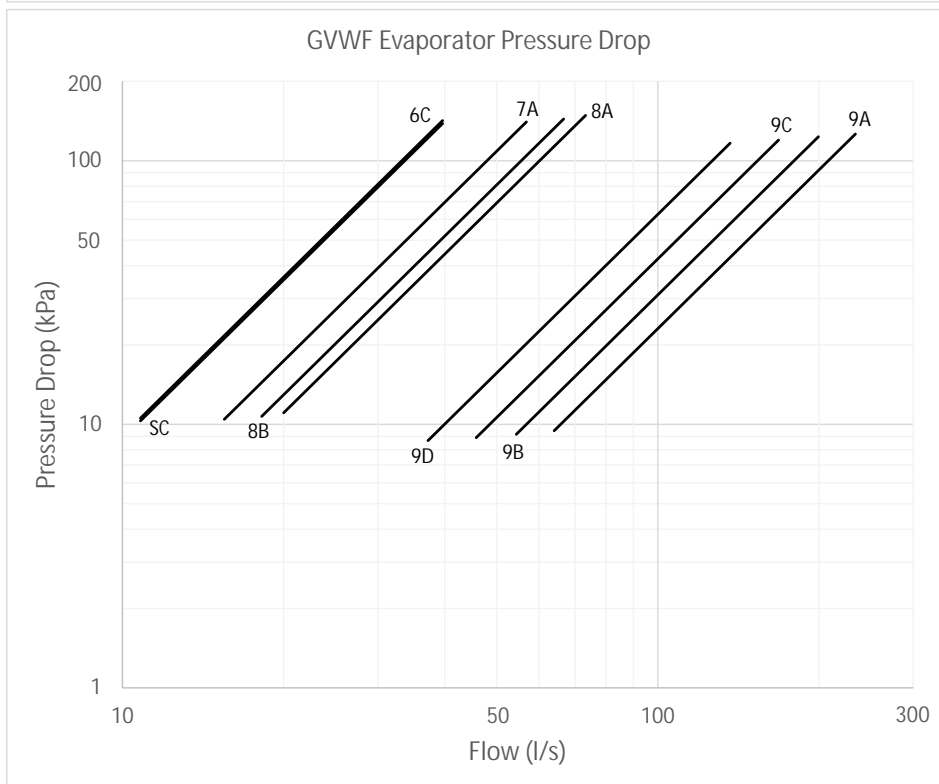
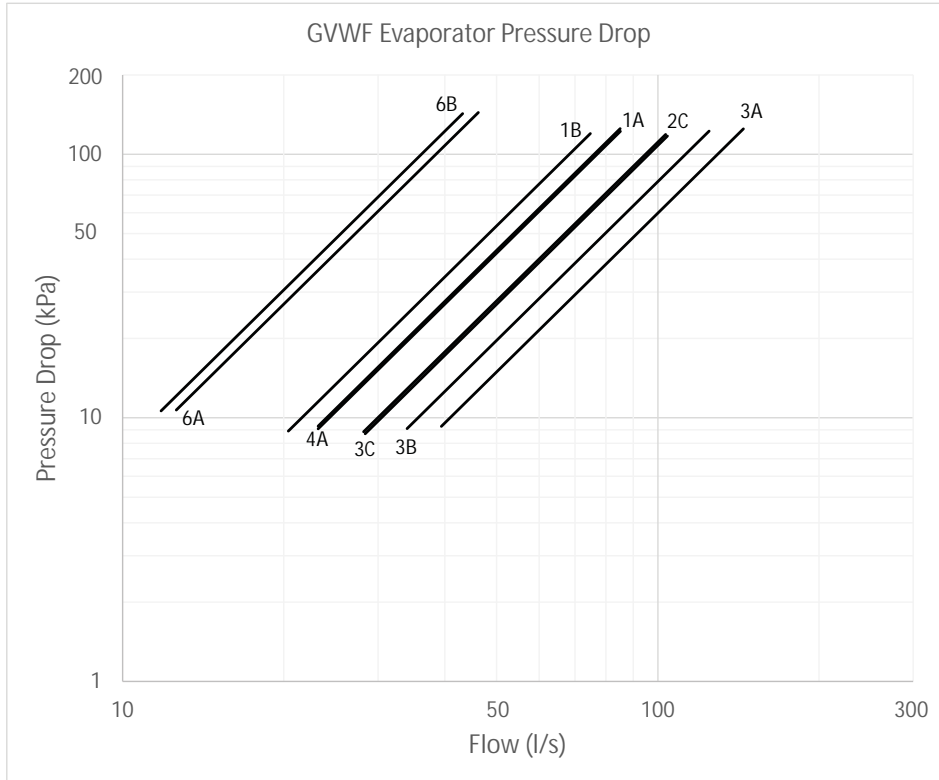

Note :
 Water pressure drop are for pure water.
 Limit of water flow are limit of the curves.

Installation - Mechanical

Figure 4 – GVWF Condenser Pressure drop

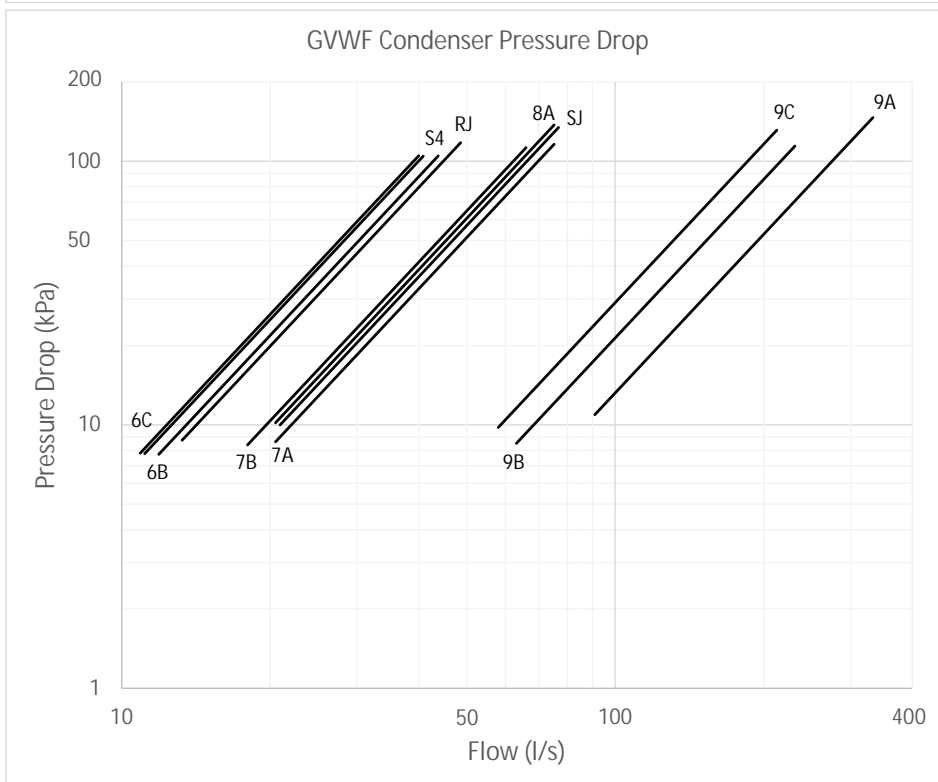
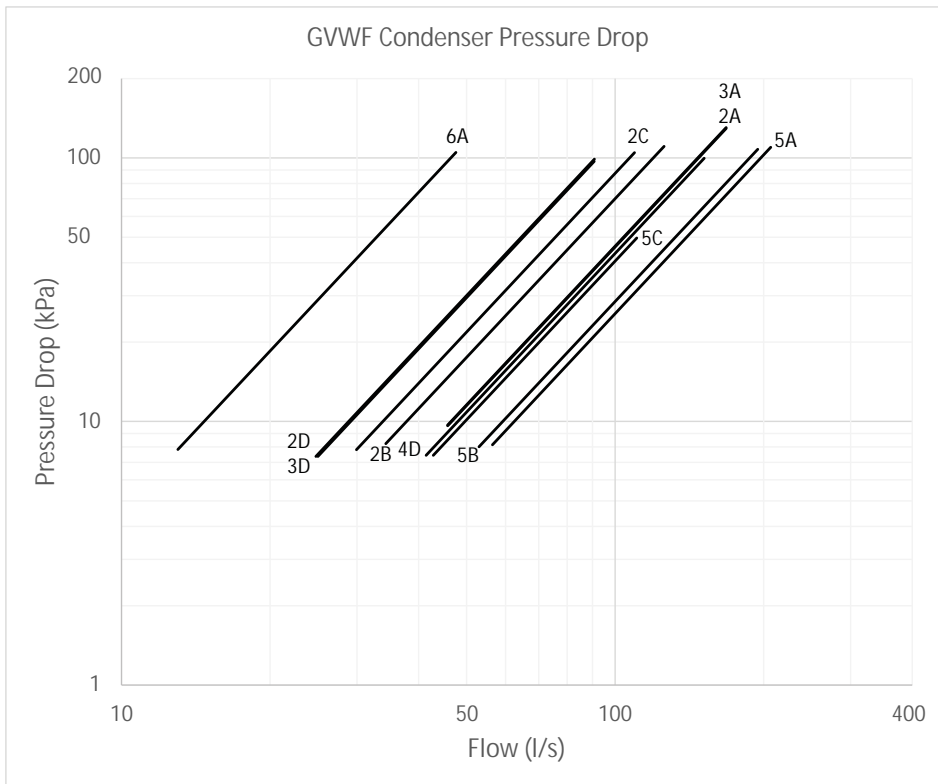



Installation - Mechanical

Freeze protection

For all chiller, it is extremely important to keep full water flow in the evaporator and condenser for an extended time after last compressor stops. This will protect evaporator and condenser tube from freezing by refrigerant migration.

This is why evaporator and condenser water pump output relay must be used to control the chilled water pump.

For unit operation in a low temperature environment, adequate protection measures must be taken against freezing. Freeze protection can be accomplished by adding sufficient glycol to protect against freezing below the lowest ambient expected.

Important: Consult manufacturer service to set LERTC and LWTC control setpoints based on the concentration of the freeze inhibitor or solution freeze point temperature.

Avoid the use of very low or near minimum chilled fluid flow rates through the chiller. Higher velocity chilled fluid flow reduces freeze risk in all situations. Flow rates below published limits have increased freeze potential and have not been considered by freeze protection algorithms.

- Avoid applications and situations that result in a requirement for rapid cycling or repeated starting and stopping of the chiller. Keep in mind that chiller control algorithms may prevent a rapid compressor restart after shutting down when the evaporator has been operating near or below the LERTC limit.
- Maintain refrigerant charge at appropriate levels. If charge is in question, contact Trane service. A reduced or low level of charge can increase the likelihood of freezing conditions in the evaporator and/or LERTC diagnostic shutdowns.

CAUTION!

1. Additional glycol beyond the recommendations will adversely affect unit performance. The unit efficiency will be reduced and the saturated evaporator temperature will be reduced. For some operating conditions this effect can be significant.

2. If additional glycol is used, then use the actual % glycol to establish the low refrigerant cutout set point.

3. The minimum low refrigerant cutout set point allowed is 0°C.

4. With glycol application, ensure that there is no fluctuation of brine flow versus Order Write Up value, as a reduction of flow will adversely affect unit performance and behaviour.

Installation - Mechanical

Condenser Water Temperatures

With the GVWF chiller, a condenser water control method is necessary only if the unit starts with condenser entering water temperatures below 13°C.

When the application requires startup temperatures below the prescribed minimum, a variety of options are available. To control a 2-way or 3-way valve, Trane offers a Condenser Regulating Valve Control option for the Symbio 800™ controls.

Condenser leaving water temperature must be 9°C higher than evaporator leaving water temperature within 2 minutes after start-up. A minimum of 14°C differential must be maintained afterwards.

The minimum acceptable compressor pressure ratio is 1.3. The chiller control system will attempt to obtain and maintain this pressure ratio.

Caution! In case of evaporator leaving water temperature applications submitted to a risk of reaching refrigerant negative saturated suction temperature, it is recommended to use glycol (or any brine type) on the heat rejection water side to avoid condenser tube freeze-up.

Condenser Water Regulation

The Condenser Head Pressure Control Option provides for a 0-10VDC (maximum range - a smaller range is adjustable) output interface to the customer's condenser water flow device. This option enables the Symbio 800™ controls to send a signal for opening and closing a 2-way or 3-way valve as necessary to maintain chiller differential pressure.

Methods other than those shown can be employed to achieve the same results. Contact your local Trane office for details.

Contact the manufacturer of the cooling device for compatibility with variable water flow.

Throttling valve (Figure 5)

This method maintains condensing pressure and temperature by throttling water flow leaving the condenser in response to condenser pressure or system differential pressures.

Advantages:

- Good control with proper valve sizing at relatively low cost.

Disadvantages:

- Increased rate of fouling due to lower condenser water velocity.
- Requires pumps that can accommodate variable flow.

Figure 5

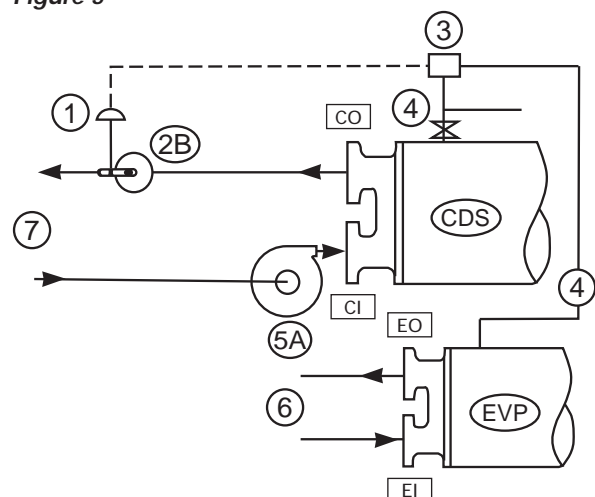

- 1 = Electric valve actuator
- 2A = 3-way valve or 2 butterfly valves
- 2B = 2 butterfly valves
- 3 = GVWF controller
- 4 = Refrigerant pressure line
- 5A = Condenser water pump
- 5B = Condenser water pump with VFD
- 6 = To/from cooling load
- 7 = To/from cooling device
- 8 = Electric controller
- EI = Evaporator Inlet
- EO = Evaporator Outlet
- CI = Condenser Inlet
- CO = Condenser Outlet

Installation - Mechanical

Cooling device bypass (Figure 6)

Cooling device bypass is also a valid control method if the chiller temperature requirements can be maintained.

Advantage:

- Excellent control by maintaining constant water flow through the condenser.

Disadvantage:

- Higher cost because of the dedicated pump required for each chiller if condenser pressure is the control signal.

Figure 6

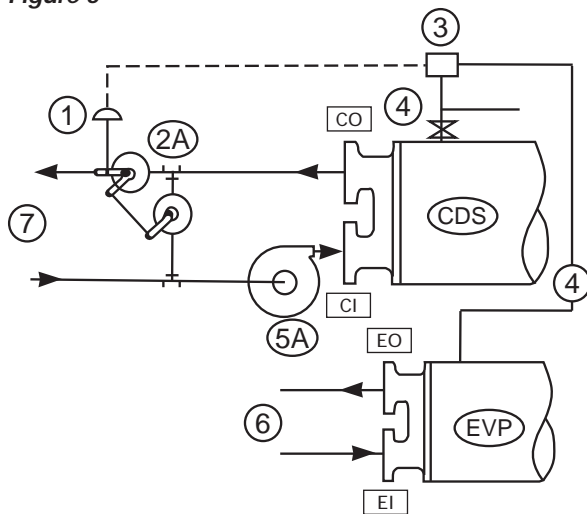

Condenser water pump with variable frequency drive (Figure 7)

Advantages:

- Pumping cost can be reduced. Good cooling device temperature control.
- Relatively low first cost.

Disadvantage:

- Increased rate of fouling due to lower water velocity in the condenser.

Figure 7

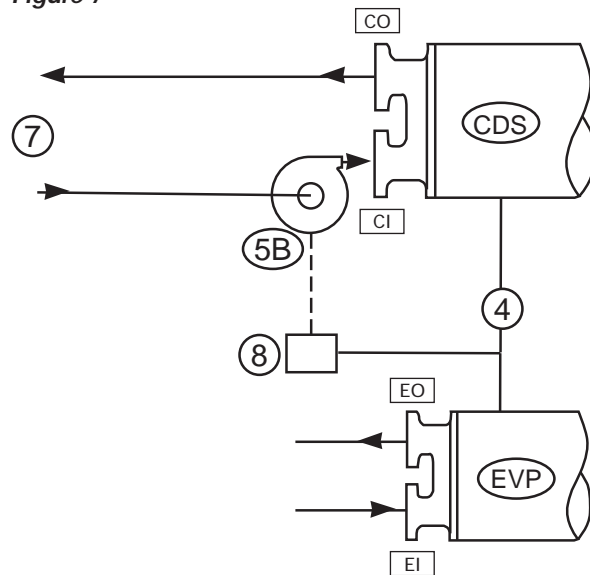

- 1 = Electric valve actuator
- 2A = 3-way valve or 2 butterfly valves
- 2B = 2 butterfly valves
- 3 = GVWF controller
- 4 = Refrigerant pressure line
- 5A = Condenser water pump
- 5B = Condenser water pump with VFD
- 6 = To/from cooling load
- 7 = To/from cooling device
- 8 = Electric controller
- EI = Evaporator Inlet
- EO = Evaporator Outlet
- CI = Condenser Inlet
- CO = Condenser Outlet

Condenser Water Regulating Valve Adjustment

A separate Settings Menu tab entitled "Condenser Head Pressure Control -Setup" that is only visible if the configuration is selected, contain the following settings and manual overrides for user adjustments and commissioning all under one tab:

- "Off State" Output Command (0-10 Vdc, 0.1 volt increments, Default 2.0 Vdc)
- Output Voltage @Desired Minimum Flow (Adj: 0 to 10.0 in 0.1 volt increments, Default 2.0 Vdc)
- Desired Minimum Flow (Adj:0-100% of full flow in 1%intervals, Default 20%)
- Output Voltage @Desired Maximum Flow (Adj: 0 to 10.0 in 0.1 volt increments (or finer),Default 10 Vdc)
- Actuator Stroke Time (Min to Max Range Time)(Adj: 1 to 1000 seconds, in 1 second increments, Default 30s)
- Damping Coefficient (adj: 0.1 to 1.8, in 0.1 increments, Default .5)
- Head Pressure Control Override (enumeration of: disabled (auto),"off" state, minimum, maximum (100%),) default : disabled (auto). When this setting is in "disabled (auto)"
- Condenser Water Pump Prerun Time

WARNING: In low temperature chilled water applications, in the case of a power loss, there is a risk of a condenser freeze-up. For low temperature chilled water applications, it is recommended to take freeze protection measures.



Installation - Electrical

General Recommendations

For proper electrical component operation, do not locate the unit in areas exposed to dust, dirt, corrosive fumes, or excessive humidity. If any of these conditions exist, corrective action must be taken.

When reviewing this manual keep in mind:

- All field-installed wiring must be in accordance with local regulations, CE directives and guidelines. Be sure to satisfy proper equipment grounding requirements according to CE.
- The following standardized values - Maximum Amps - Short Circuit Amps - Starting Amps are displayed on unit nameplate.
- All field-installed wiring must be checked for proper terminations, and for possible shorts or grounds.

Note: always refer to wiring diagrams shipped with chiller or unit submittal for specific electrical schematic and connection information.

Important: to prevent control malfunctions, do not run low voltage wiring (<30V) in conduit with conductors carrying more than 30 volts.

WARNING! Hazardous Voltage with Capacitor!

Disconnect all electric power, including remote disconnects and discharge all motor start/run and Drive capacitors before servicing. Follow proper lockout/tagout procedures to ensure the power cannot be inadvertently energized.

- For variable frequency drives or other energy storing components provided by Trane or others, refer to the appropriate manufacturer's literature for allowable waiting periods for discharges capacitors. Verify with an appropriate voltmeter that all capacitors have discharged.
- DC bus capacitors retain hazardous voltages after input power has been disconnected. Follow proper lockout/tagout procedures to ensure the power cannot be inadvertently energized.

After disconnecting input power, wait twenty (20) minutes for units which are equipped with variable frequency drive (0V DC) before touching any internal components.

Failure to follow these instructions could result in death or serious injury.

However for any intervention on frequency drive the indicated waiting time on the Frequency drive label must be respected.

Before installing the chiller, the user must evaluate the potential electromagnetic problems in the surrounding area. The following should be considered:

- a) the presence above, below and adjacent to the unit of for example: welding equipment or other power cables, control cables or signaling and telephone cables;
- b) receivers and transmitters, radio and television;
- c) computer and other control equipment ;
- d) the critical safety equipment, eg protection of industrial equipment ;
- e) the health of neighboring persons, for example, use of pacemakers or appliances against deafness ;
- f) the immunity of other equipment in the environment.

The user must ensure that the other materials used in the environment are compatible. This may require additional protection measures;

If electromagnetic disturbances are detected, it shall be the responsibility of the user to resolve the situation.

In any case, the electromagnetic interferences have to be reduced until they are no longer troublesome.

All wiring must comply with national electric regulations. Minimum circuit ampacities and other unit electrical data is on the unit nameplate. See the unit order specifications for actual electrical data. Specific electrical schematics and connection diagrams are shipped with the unit.

Do not allow conduit to interfere with other components, structural members or equipment. Control voltage (110V) wiring in conduit must be separate from conduit carrying low voltage (<30V) wiring. To prevent control malfunctions, do not run low voltage wiring (<30V) in conduit with conductors carrying more than 30V.

Installation - Electrical

Power Supply Wiring

Model GVWF chillers are designed according to European standard EN 60204-1; therefore, all power supply wiring must be sized and selected accordingly by the project engineer.

Water Pump Power Supply

Provide power supply wiring with fused disconnect for both the chilled water and condenser water pumps.

Electrical Panel Power Supply

Power supply wiring instructions for the starter/control panel are:

Run the line voltage wiring in conduit to the access opening(s) on the starter/control panel. See the product catalog for wire sizing and selection information and refer to general data that show typical electrical connection sizes and locations. Always refer to submittal information for your actual unit specifications.

Note: Asterisked connections require the user to provide an external source of power. The 110V control power transformer is not sized for additional load.

Units are compatible with the following neutral operating conditions:

TNS	IT	TNC	TT
Standard	Special - on request	Special - on request	Special - on request

Differential protection should be suited for industrial machinery with current leak which can be higher than 500 mA (several motors and frequency drives).

CAUTION! To avoid corrosion, overheating or general damage, at terminal connections, unit is designed for copper conductors only. In case of aluminum cable, bi-material connecting devices are mandatory. Cable routing inside control panel should be made case by case by installer.

Module and Control Panel Connectors

All connectors can be unplugged or the wires can be removed. If an entire plug is removed, make sure the plug and the associated jack are marked for proper location identification during reinstallation.

All electrical drawings, schematics and control panel layout are included in the documentation package sent with the chiller.

Interconnecting Wiring (Field Wiring Required)

Important: Do not turn chiller on or off using the chilled water pump interlocks.

When making field connections, refer to the appropriate field layout, wiring, schematics and controls diagrams that ship with the unit. Whenever a contact closure (binary output) is referenced, the electrical rating is:

At 120 VAC	7.2 amp resistive
	2.88 amp pilot duty
	250 W, 7.2 FLA, 43.2 LRA
At 240 VAC	5.0 amp resistive
	2.0 amp pilot duty
	250 W, 3.6 FLA, 21.3 LRA

Whenever a dry contact input (binary input) is referenced, the electrical rating is 24VDC, 12 mA.

Whenever a control voltage contact input (binary input) is referenced, the electrical rating is 120 VAC, 5mA.

Note: Asterisked connections require the user to provide an external source of power. The 115V control power transformer is not sized for additional load.

Chilled Water Pump Control

Symbio™ 800 has a evaporator water pump output relay that closes when the chiller is given a signal to go into the Auto mode of operation from any source. The contact is opened to turn off the pump in the event of most machine level diagnostics to prevent the build up of pump heat. To protect against the build-up of pump heat for those diagnostics that do not stop and/or start the pump and to protect against the condition of a bad flow switch, the pump shall always be stopped when refrigerant pressure is seen to be close to heat exchanger design pressure.



Installation - Electrical

Chilled Water Flow Interlock

Symbio™ 800 has an input that will accept a contact closure from a proof-of-flow device such as a flow switch. The flow switch is to be wired in series with the chilled water pump starter's auxiliary contacts. When this input does not prove flow within 20 minutes relative to transition from Stop to Auto modes of the chiller, or if the flow is lost while the chiller is in the Auto mode of operation, the chiller will be inhibited from running by a non-latching diagnostic. The flow switch input shall be filtered to allow for momentary openings and closings of the switch due to turbulent water flow. This is accomplished with a 6 seconds filtering time. The sensing voltage for the condenser water flow switch is 115/240 VAC

IMPORTANT! DO NOT cycle the chiller through starting and stopping the chilled water pump. This could cause the compressor to shut down fully loaded. Use the external stop/start input to cycle the chiller.

Condenser Water Pump Control

Symbio™ 800 provides a contact closure output to start and stop the condenser water pump. If condenser pumps are arranged in a bank with a common header, the output can be used to control an isolation valve and/or signal another device that an additional pump is required.

Condenser Water Pump Prestart time has been added to help with cold condenser water problems. In very cold outdoor ambient, the cooling device's sump would reach the chiller some time after the low system differential pressure protection had run through its ignore time, and result in an immediate shutdown and latching diagnostic. By simply starting the pump earlier, and allowing mixing of the warmer indoor loop with the cooling device's sump, this problem can be avoided.

Condenser Water Flow Interlock

The Symbio™ 800 shall accept an isolated contact closure input from a customer installed proof-of-flow device such as a flow switch and customer provided pump starter auxiliary contact for interlocking with condenser water flow.

The input shall be filtered to allow momentary openings and closings of the switch due to turbulent water flow, etc. This shall be accomplished with a 6 seconds filtering time. The sensing voltage for the condenser water flow switch is 115/240 VAC.

On a call for cooling after the restart inhibit timer has timed out, the Symbio™ 800 shall energize the condenser water pump relay and then check the condenser water flow switch and pump starter interlock input for flow confirmation.

Startup of the compressor will not be allowed until flow has proven. If flow is not initially established within 1200 seconds (20 minutes) of the condenser pump relay energizing, an automatically resetting diagnostic "Condenser Water Flow Overdue" shall be generated which terminates the prestart mode and denergizes the condenser water pump relay. This diagnostic is automatically reset if flow is established at any later time.

Note: This diagnostic would never automatically reset if Symbio™ 800 was in control of the condenser pump through its condenser pump relay since it is commanded off at the time of the diagnostic. It could however reset and allow normal chiller operation if the pump was controlled from some external source.

Programmable Relays (Alarm and Status)

Symbio™ 800 provides a flexible alarm or chiller status indication to a remote location through a hard wired interface to a dry contact closure. 4 relays are available for this function as a Quad Relay Output LLID and a second quad relay board can be field mounted if more than 4 different alarm/status are needed (refer to your local Trane service). The events/states that can be assigned to the programmable relays are listed in the following table.

Installation - Electrical

The Symbio™ 800 Service Tool (TU) is used to install and assign any of the above listed events or status to each of the 4 relays. The default assignments for the 4 available relays are listed below.

LLID Name	LLID Software Relay Designation	Output Name	Default
Operating Status Programmable Relays	Relay 0	Status Relay 1, J2-1,2,3	Evaporator Freeze Avoidance Request
	Relay 1	Status Relay 2, J2-4,5,6	Maximum Capacity
	Relay 2	Status Relay 3, J2-7,8,9	Compressor Running
	Relay 3	Status Relay 4, J2-10,11,12	Latching Alarm

Latching input

The Symbio™ 800 provides auxiliary control for a customer specified/installed latching trip out. When this customer-furnished remote contact is provided, the chiller will run normally when the contact is closed. When the contact opens, the unit will trip off on a manually resettable diagnostic. This condition requires manual reset at the chiller switch on the front of the control panel.

External Auto/Stop

If the unit requires the external Auto/Stop function, the installer must provide leads from the remote contacts to the proper terminals of the LLID on the control panel. The chiller will run normally when the contacts are closed. When the contact opens, the compressor(s), if operating, will go to the RUN : UNLOAD operating mode and cycle off. Unit operation will be inhibited. Re-closure of the contacts will permit the unit to automatically return to normal operation.

NOTE: A "panic " stop (similar to "emergency " stop) can be manually commanded by pressing the STOP button twice in a row, the chiller will immediately shut down, but without creating a latching diagnostic.

Soft Loading

Soft loading will prevent the chiller from going to full capacity during the pull-down period. The Symbio™ 800 control system has two soft loading algorithms running all of the time. They are capacity control soft loading and current limit soft loading. These algorithms introduce the use of a Filtered Chilled Water Setpoint and a Filtered Current Limit Setpoint. After the compressor has been started, the starting point of the filtered chilled water setpoint is initialized to the value of the Evap Leaving Water Temperature. The filtered current limit setpoint is initialized to the value of the Current Limit Softload Starting Percent. These filtered setpoints allow for a stable pull-down that is user adjustable in duration. They also eliminate sudden transients due to setpoint changes during normal chiller operation.

3 settings are used to describe the behavior of soft loading. The setup for soft loading can be done using TU.

- Capacity Control SoftloadTime: This setting controls the time constant of the Filtered Chilled Water Setpoint. It is settable between 0 and 120 min.
- Current Limit Control SoftloadTime: This Setting controls the time constant of the Filtered Current Limit Setpoint. It is settable between 0 and 120 minutes.
- Current Limit Softload Starting %: This setting controls the starting point of the Filtered Current Limit Setpoint. It is adjustable from 20 to 100% RLA.



Installation - Electrical

LonTalk Communication Interface - Optional

Symbio™ 800 provides an optional LonTalk Communication Interface (LCI-C) between the chiller and a BAS. An LCI-C LLID shall be used to provide “gateway” functionality between the LonTalk protocol and the chiller.

Bacnet Communication Interface - Optional

Symbio™ 800 provides an optional Bacnet communication interface between the chiller and a BAS. Bacnet communication capability is fully integrated on Symbio™ 800. For further information see Integration Guide.

Modbus Communication Interface - Optional

Symbio™ 800 provides an optional Modbus communication Interface between the chiller and a BAS. Modbus communication capability is fully integrated on Symbio™ 800. For further information see the Integration guide.

External Chilled Water Setpoint - Optional

Symbio™ 800 will accept either a 2-10 VDC or a 4-20 mA input signal, to adjust the chilled water setpoint from a remote location.

Auxiliary Chilled/Hot Setpoint Contact - Optional

Symbio™ 800 accepts a contact closure input to switch from BAS/External/Front Panel setpoint to a customer defined auxiliary setpoint. By default, chilled water auxiliary setpoint is set to 9°C and hot water auxiliary setpoint is set to 33°C.

External Demand Limit Setpoint - Optional

Symbio™ 800 will accept either a 2-10VDC or a 4-20mA input signal to adjust the Demand limit setpoint from a remote location.

Percent Condenser Pressure Output - Optional

Symbio™ 800 provides a 2-10 VDC analog output to indicate condenser pressure in percent of software High Pressure Cutout (soft HPC).

Percent HPC = (Lowest Condenser Pressure of all running circuits (abs) / Soft HPC (abs)) * 100.

Refrigerant Differential Pressure Indication - Optional

Symbio™ 800 provides a 2-10 VDC analog output to indicate refrigerant differential pressure with the endpoints customer defined.

Refrigerant Differential Pressure = Lowest of (condenser refrigerant pressure cktx - evaporator refrigerant pressure cktx).

Condenser water flow control output - Optional

Symbio™ 800 provides a 2-10 VDC analog output to indicate mixing valve/pump on condenser water. The control is based on a proportionnal Integral algorithm adjusting minimum condenser pressure setpoint.

Operating Principles Mechanical

This section contains an overview of the operation and maintenance of GVWF chiller equipped with microcomputer-based control systems. It describes the overall operating principles of the GVWF design. Following the section is information regarding specific operating instructions, detailed descriptions of the unit controls and options and maintenance procedures that must be performed regularly to keep the unit in top condition. Diagnostic information is provided to allow the operator to identify system malfunctions.

Note: To ensure proper diagnosis and repair, contact a qualified service organization if a problem should occur.

General

According to capacity, GVWF have one circuit with one compressor (for sizes 115 & 140 XSE G) or two circuits with 2, 3 or 4 compressors for all other sizes. Each refrigerant circuit includes a compressor suction and discharge service valve, liquid line shutoff valve, removable core filter, liquid line sight glass with moisture indicator, charging port and electronic expansion valve. Fully modulating compressors and electronic expansion valve provide variable capacity modulation over the entire operating range.

Refrigerant Cycle

Typical refrigerant cycle on the GVWF is represented on the pressure enthalpy diagram shown in the figure below. Key state points are indicated on the figure. The cycle for the full load design point is represented in the plot.

Figure 8 – Pressure enthalpy (P-h) diagram

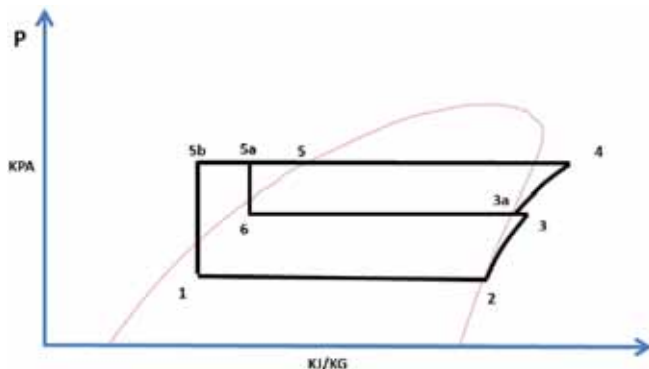

The GVWF chiller uses a shell and tube evaporator design with refrigerant evaporating on the shell side and water flowing inside tubes having enhanced surfaces (state 1 to 2).

The vaporized refrigerant flows into the compressor first stage through compressor inlet guide valves. The first stage impeller accelerates the vapor increasing its temperature and pressure to intermediate state 3. Refrigerant vapor leaving the first stage compressor is mixed with cooler refrigerant vapor from the economizer (BPHE). This mixing lowers the enthalpy of the vapor entering the second stage to stage 3a. The second stage impeller accelerates the vapor, further increasing its temperature and pressure to state point 4.

De-superheating, condensing and sub-cooling are accomplished in a Shell and tubes condenser (state 5 and 5a). Liquid refrigerant leaves the condenser at point 5a and a part of it flows to the secondary expansion valve and enters BPHE economizer at point 6 and then the flow is vaporized to the compressor economizer port at state 3a. Meanwhile the major part flows to BPHE economizer acting as an additive subcooler and refrigerant is cooled down to state 5b then the major part of the liquid flow goes through the main expansion valve and returns to the evaporator at state 1.

Refrigerant

GVWF use R134a/R513A or R1234ze(E)/R515B, Trane believes that responsible refrigerant practices are important to the environment, our customers, and the air conditioning industry. All technicians who handle refrigerants must be properly qualified. All local and EU regulations in which R134a/R513A/R1234ze(E)/R515B are specified as medium pressure refrigerant must be observed. Handling, reclaiming, recovering and recycling instructions must be followed. R1234ze(E)/R515B requires specific care and dedicated refrigerant hoses and recovery system without oil residue have to be used.

Compressor

The centrifugal oil free compressor with frictionless magnetic bearings is a semi hermetic design with twin impellers. It has a 3 phase AC voltage input with built in service inverter for motor speed control. Compressor control, motor control, motor cooling control and bearing control are handled by embedded electronics. Sensor rings check shaft position 8000 times per second and most of the work is done by permanent magnets while electromagnets are used to fine tune the shaft position within less than 10µm of correction.

Evaporator

The evaporator is a shell and tube heat exchanger design constructed from carbon steel shells and tube sheets with internally and externally finned seamless copper tubes mechanically expanded into the tube sheets. Tubes are cleanable with dismountable water boxes. Tubes diameter exterior is 19mm. Each tube is individually replaceable.

The evaporator is designed, tested and stamped in accordance with PED 2014/68/EU Pressure regulation for a refrigerant side working pressure of 13 bars. Standard water connections are grooved for Victaulic style pipe couplings. Water boxes are available in 1 or 2 passes configurations according to unit size and include an air vent, a drain and fittings for temperature control sensors. Evaporator is insulated with closed cell insulation.

GVWF Operating map

GVWF 115, 230, 345 & 460 XSE G

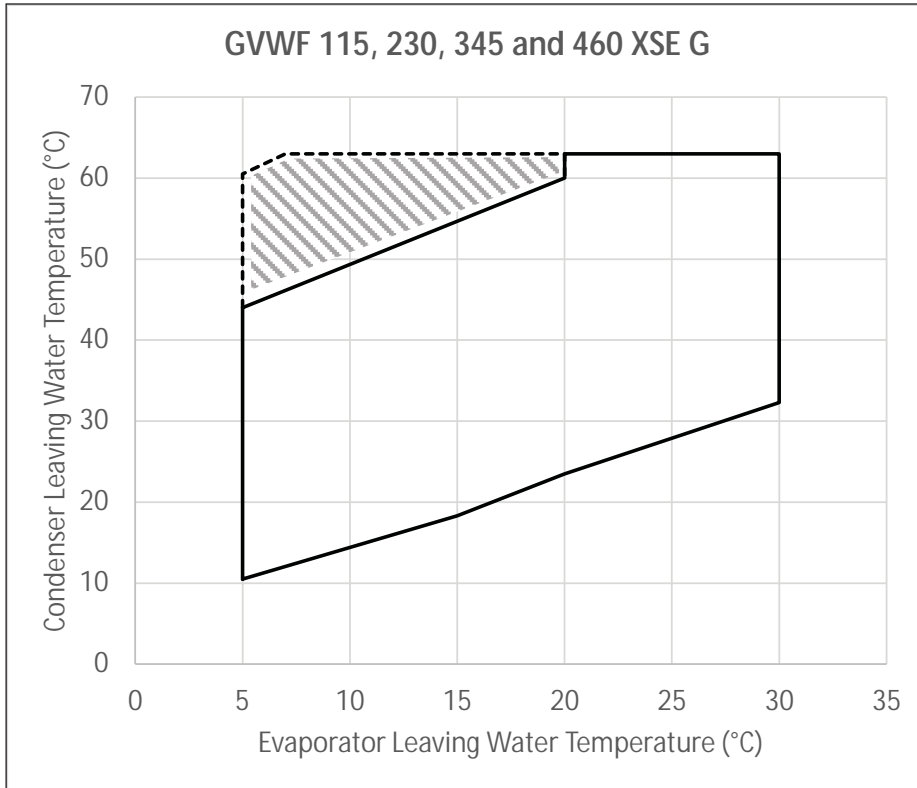

Please reach your Trane sales representative when selecting a unit in the grey shaded areas

GVWF 140, 280, 540 & 620 XSE G

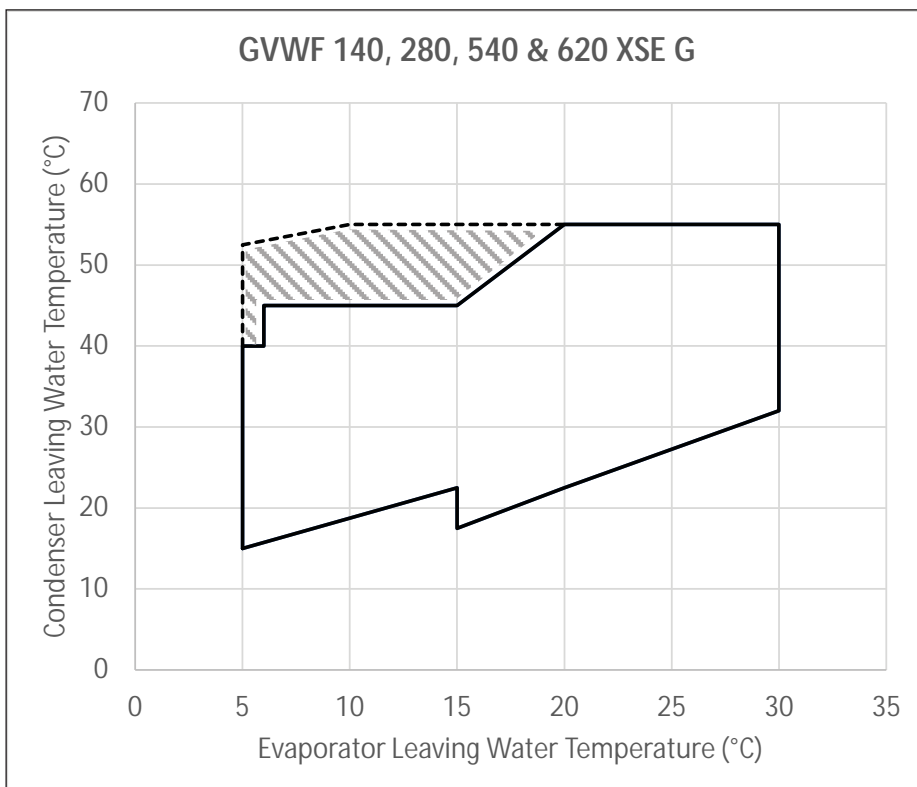

Please reach your Trane sales representative when selecting a unit in the grey shaded areas

GVWF Operating map

GVWF 135 G - 375 G
GVWF 150 - 760

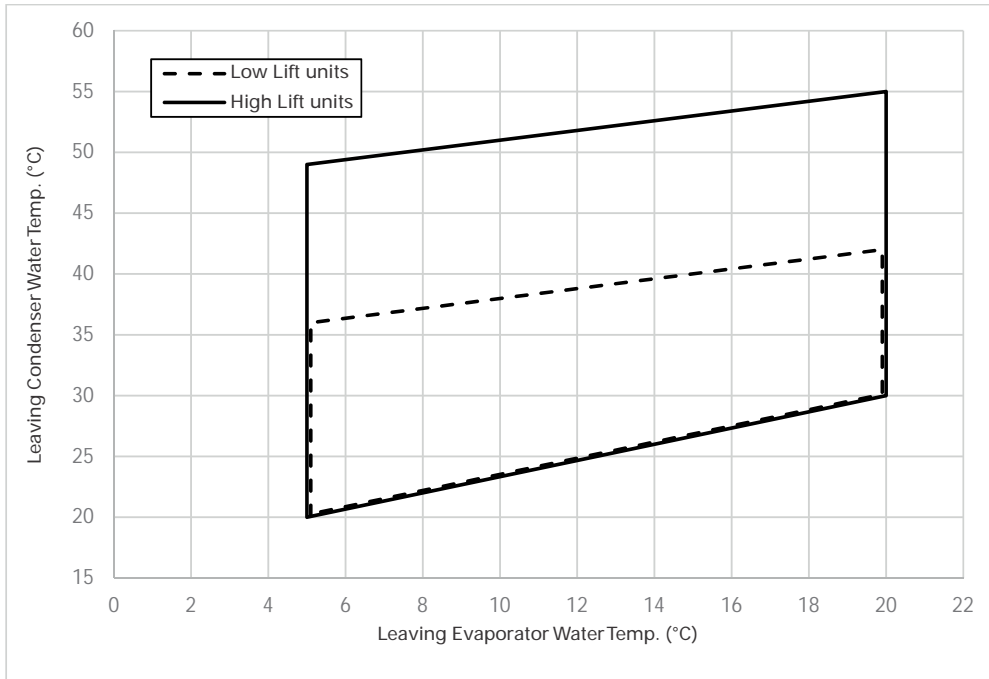



Controls/Tracer TD7 Operator Interface

Controls Overview

GVWF units use the following control/interface components:

- Symbio™ 800 Controller
- Tracer TD7 Operator Interface

Communication Interfaces

There are four connections on the Symbio™ 800 that support the communication interface. See Unit User Guide to locate the following ports: "Wiring and Ports Description" section.

- BACnet™ MSTP
- BACnet™ IP
- ModBus™ RTU
- ModBus™ TCP-IP
- LonTalk™ (LCI-C)

See chiller User Guide for information on communication interface.

Tracer TD7 Operator Interface

Operator Interface

Information is tailored to operators, service technicians and owners. When operating a chiller, there is specific information you need on a day-to-day basis, like setpoints, limits, diagnostic information, and reports. Day-to-day operational information is presented at the display. Logically organized groups of information-chiller mode of operation, active diagnostics, settings and reports put information conveniently at your fingertips.

Tracer™ TU

The TD7 operator interface allows for daily operation tasks and setpoint changes. However to adequately service GVWF chillers, Tracer™ TU service tool is required (Non-Trane personnel, contact your local Trane office for software purchase information). Tracer TU adds a level of sophistication that improves service technician effectiveness and minimizes chiller downtime. This portable PC-based service-tool software supports service and maintenance tasks.

Pre-Start Checkout

Installation Checklist

Complete this checklist as the unit is installed, and verify that all recommended procedures are accomplished before the unit is started. This checklist does not replace the detailed instructions given in the "Installation Mechanical" and "Installation Electrical" sections of this manual. Read both sections completely, to become familiar with the installation procedures, prior beginning the work.

General

When installation is complete, before starting the unit, the following prestart procedures must be reviewed and verified:

1. Inspect all wiring connections in the compressor power circuits (disconnects, terminal block, contactors, compressor junction box terminals and so forth) to ensure they are clean and tight.
2. Open all refrigerant valves in the discharge and liquid lines.
3. Check the power-supply voltage to the unit at the main-power fused-disconnect switch. Voltage must be within the voltage use range and also stamped on the unit nameplate. Voltage fluctuation must not exceed 10%. Voltage imbalance must not exceed 2%.
4. Check the unit power phasing L1-L2-L3 in the starter to ensure that it has been installed in a "A-B-C" phase sequence.
5. Fill the evaporator and condenser water circuit. Vent the system while it is being filled. Open the vents on the top of the evaporator water and condenser boxes while filling and close when filling is completed.
6. Close the fused-disconnect switch(es) that supplies power to the chilled-water pump starter.
7. Start the evaporator and condenser water pump to begin circulation of the water. Inspect all piping for leakage and make any necessary repairs.
8. With water circulating through the system, adjust the water flow and check the water pressure drop through the evaporator and condenser.
9. Adjust the chilled-water flow switch for proper operation.
10. Reapply power to complete the procedures.
11. Prove all Interlock and Interconnecting Wiring Interlock and External as described in the Electrical Installation section.
12. Check and set, as required, all Symbio™ 800TD7 menu items.
13. Stop the evaporator and condenser water pump.

Unit Voltage Power Supply

Unit voltage must meet the criteria given in the installation Electrical Section. Measure each lead of the supply voltage at the main power fused-disconnect switch for the unit. If the measured voltage on any lead is not within the specified range, notify the supplier of the power and correct the situation before operating the unit.

Water System Flow Rates

Establish a balanced chilled-water flow through the evaporator. The flow rates should be between the minimum and maximum values given on the pressure drop curves.

Water System Pressure Drop

Measure the water-pressure drop through the evaporator on the field installed pressure taps on the system water piping. Use the same gauge for each measurement. Do not include valves, strainers, or fittings in the pressure drop readings.



Unit Start-up

Daily Unit Start Up

The timeline for the sequence of operation begins with a power-up of the main power to the chiller. GVWF Water cooled chiller verifies there are no diagnostics which could prevent the unit of starting. External events such as the operator placing the chiller in AUTO or STOP, chilled water flow through the evaporator, and application of load to the chilled water loop causing loop water-temperature increases, are depicted and the chiller responses to those events are shown, with appropriate delays noted. The effects of diagnostics, and other external interlocks other than evaporator water-flow proving, are not considered.

Note: unless the Symbio™ 800TD7 and building automation system are controlling the chilled-water pump, the manual unit start sequence is as follows. Operator actions are noted.

General

If the present checkout, as discussed above, has been completed, the unit is ready to start.

1. Press the STOP key on the TD7 display.
2. As necessary, adjust the set point values on the TD7 menus using Tracer TU.
3. Close the fused-disconnect switch for the chilledwater pump. Energize the pump(s) to start water circulation
4. Check the service valves on the discharge line, suction line and liquid line for each circuit. These valves must be open (back seated) before starting the compressors.
5. Verify that chilled-water pump runs for at least one minute after the chiller is commanded to stop (for normal chilled-water systems).
6. Press the AUTO key. If the chiller control calls for cooling, and all safety interlocks are closed, the unit will start. The compressor(s) will load and unload in response to the leaving chilled – water temperature;

After the system has been operating for approximately 30 minutes and has become stabilized, complete the remaining start up procedures, as follows:

1. Check the evaporator refrigerant pressure and the condenser refrigerant pressure under Refrigerant Report on the TD7.
2. Check the EXV sight glasses after enough time has elapsed to stabilize the chiller. The refrigerant flow through the sight glasses should be clear. Bubbles in the refrigerant indicate either low refrigerant charge or excessive pressure drop in the liquid line, or an expansion valve that is stuck open. A restriction in the line can sometimes be identified by a noticeable temperature differential between the two sides of the restriction. Frost will often form on the line at this point. Proper refrigerant charges are shown in the General Information Section;
3. Measure the system discharge superheat.

Seasonal Unit Startup Procedure

1. Close all valves and reinstall the drain plugs in the evaporator and condenser.
2. Service the auxiliary equipment according to the startup and maintenance instructions provided by the respective equipment manufacturers.
3. Close the vents in the evaporator and condenser water circuits.
4. Open all the valves in the evaporator and condenser water circuits.
5. Open all refrigerant valves.
6. If the evaporator and condenser were previously drained, vent and fill the evaporator and condenser water circuit. When all air is removed from the system (including each pass), install the vent plugs in the evaporator and condenser water boxes.
7. Check the adjustment and operation of each safety and operating control.
8. Close all disconnect switches.
9. Refer to the sequence for daily unit start up for the remainder of the seasonal start up.

Periodic Maintenance

Overview

This section describes preventative maintenance procedures and intervals for the unit. Use a periodic maintenance program to ensure optimal performance and efficiency of the units. An important aspect of the chiller maintenance program is the regular completion of the "Operating Log". When filled out properly the completed logs can be reviewed to identify any developing trends in the chiller's operating conditions.

Weekly Maintenance and Checks

After the unit has operated for approximately 30 minutes and the system has stabilized, check the operating conditions and complete the procedures below:

- Log the chiller.
- Check evaporator and condenser pressures with gauges and compare to the reading on the Clear Language Display. Pressure readings should fall within the following ranges specified in the Operating Conditions.

NOTE: Optimum condenser pressure is dependent on condenser water temperature, and should equal the saturation pressure of the refrigerant at a temperature 1 to 3°C above that of leaving condenser water at full load.

Monthly Maintenance and Checks

- Review operating log.
- Clean all water strainers in both the chilled and condensing water piping systems.
- Measure and log the subcooling and superheat.
- If operating conditions indicate a refrigerant shortage, leak check the unit using soap bubbles.
- Repair all leaks.
- Trim refrigerant charge until the unit operates in the conditions listed in the note below.

Note: condenser water: 30/35°C and evaporator water: 12/7°C.

Annual Maintenance

WARNING: Hazardous Voltage!

Disconnect all electric power, including remote disconnects before servicing. Follow proper lockout / tagout procedures to ensure the power can not be inadvertently energized. Failure to disconnect power before servicing could result in death or serious injury.

- Shut down the chiller once each year to check the following:
- Perform all weekly and monthly maintenance procedures.
- Check the refrigerant charge. Refer to "Maintenance Procedures".
- Contact a qualified service organization to leak check the chiller, to inspect safety controls, and inspect electrical components for deficiencies.
- Inspect all piping components for leakage and/or damage. Clean out any inline strainers.
- Clean and repaint any areas that show signs of corrosion.
- Test vent piping of all relief valves for presence of refrigerant to detect improperly sealed relief valves. Replace any leaking relief valve.
- Inspect the condenser tubes for fouling; clean if necessary. Refer to "Maintenance Procedures".
- Check to make sure that the crank case heater is working.

Scheduling Other Maintenance

- Use a nondestructive tube test to inspect the condenser and evaporator tubes at 3-year intervals.

NOTE: It may be desirable to perform tube tests on these components at more frequent intervals, depending upon chiller application. This is especially true of critical process equipment.

- Depending on chiller duty, contact a qualified service organization to determine when to conduct a complete examination of the unit to determine the condition of the compressor and internal components.
- Follow national regulation when special prescriptions.



Periodic Maintenance

Contractor Confirmation Check Sheet

This check sheet must be completed by the installing contractor and submitted prior to requesting Trane Service start-up support. The check sheet identifies a list of items that need to be completed prior to actual machine start-up.

Contractor Confirmation Check Sheet	
Addressed to the Trane Service office of:	
Job Name:	Job location:
Model No.:	Sales order No.:
Unit	Cooling water
<input type="checkbox"/> Unit installed	<input type="checkbox"/> Connected to the unit
<input type="checkbox"/> Isolator pads in place	<input type="checkbox"/> Connected to the cooling device
Chilled Water	<input type="checkbox"/> Connected to the pumps
<input type="checkbox"/> Connected to the unit	<input type="checkbox"/> System flushed and then filled
<input type="checkbox"/> Connected to the air handling units	<input type="checkbox"/> Pumps run and air bled
<input type="checkbox"/> Connected to the pumps	<input type="checkbox"/> Strainers cleaned
<input type="checkbox"/> System flushed and then filled	<input type="checkbox"/> Flow switch installed and checked/set
<input type="checkbox"/> Pumps run and air bled	<input type="checkbox"/> Throttling cock installed in leaving water
<input type="checkbox"/> Strainers cleaned	<input type="checkbox"/> Thermometers installed in leaving/entering water
<input type="checkbox"/> Flow switch installed and checked/set	<input type="checkbox"/> Gauges installed in leaving/entering water
<input type="checkbox"/> Throttling cock installed in leaving water	<input type="checkbox"/> Cooling water control operational
<input type="checkbox"/> Thermometers installed in leaving/entering water	<input type="checkbox"/> Water treatment equipment
<input type="checkbox"/> Gauges installed in leaving/entering water	Wiring
	<input type="checkbox"/> Power supply connected and available
	<input type="checkbox"/> External interlock connected
	Load
	<input type="checkbox"/> System can be operated under load condition

We will therefore require your service technician on job by* _____.

Checklist completed by _____.

Date _____.

* Return this completed checklist to your Trane Service office as soon as possible to enable the start-up visit to be scheduled. Be aware that advance notification is required to allow scheduling of the start-up as close to the requested date as possible. Additional time required to complete the start-up and adjustment due to incompleteness of the installation will be invoiced at prevailing rates.

Maintenance Procedures

Cleaning the Condenser

CAUTION: Proper Water Treatment!

The use of untreated or improperly treated water in a GVWF may result in scaling, erosion, corrosion, algae or slime. It is recommended that the services of a qualified water treatment specialist be engaged to determine what water treatment, if any, is required. The manufacturer assumes no responsibility for equipment failures which result from untreated or improperly treated water, saline or brackish water.

Condenser tube fouling is suspect when the "approach" temperature (i.e., the difference between the refrigerant condensing temperature and the leaving condenser water temperature) is higher than predicted. Standard water applications will operate with less than a 5°C approach. If the approach exceeds 5°C and there is no-condensable in the system cleaning the condenser tubes is recommended.

NOTE: Glycol in the water system typically doubles the standard approach.

If the annual condenser tube inspection indicates that the tubes are fouled, 2 cleaning methods can be used to rid the tubes of contaminants. The methods are:

Mechanical Cleaning Procedure

Mechanical tube cleaning this method is used to remove sludge and loose material from smooth-bore condenser tubes.

1. Remove the retaining bolts from the water boxes at each end of the condenser. Use a hoist to lift the water boxes.
2. Work a round nylon or brass bristled brush (attached to a rod) in and out of each of the condenser water tubes to loosen the sludge.
3. Thoroughly flush the condenser water tubes with clean water. (To clean internally enhanced tubes, use a bi-directional brush or consult a qualified service organization for recommendations.)

Chemical Cleaning Procedure

Scale deposits are best removed by chemical means. Consult a qualified water treatment specialist (i.e., one that knows the local water supply chemical/mineral content) for a recommended cleaning solution suitable for the job. (A standard condenser water circuit is composed solely of copper, cast iron and steel.) Improper chemical cleaning can damage tube walls.

All of the materials used in the external circulation system, the quantity of the solution, the duration of the cleaning period, and any required safety precautions should be approved by the company furnishing the materials or performing the cleaning.

NOTE: Chemical tube cleaning should always be followed by mechanical tube cleaning.

Cleaning the Evaporator

Since the evaporator is typically part of a closed circuit, it does not accumulate appreciable amounts of scale or sludge. However, if cleaning is deemed necessary, use the same cleaning methods described for the condenser tubes.

Refrigerant Charge

If a low refrigerant charge is suspected, first determine the cause of lost refrigerant. Once the problem is repaired follow the procedures below for evacuating and charging the unit.

Refrigerant recovery

1. Insure that the water flow is maintained on condenser and evaporator during all the recovery operation.
2. Connections on evaporator and condenser are available to remove the refrigerant. Weight the refrigerant removed.

CAUTION !

Never recover refrigerant without maintaining nominal water flow on heat exchangers during all the recovery operation. Evaporator or condenser could freeze and bringing severe damages to the unit.

3. Use a "refrigerant transfer machine" and adequate service cylinders to stock the recovered refrigerant. For GVWF centrifugal machines, it is imperative to use hoses and refrigerant transfer equipment specifically designed for the refrigerant in question to avoid any contamination of the refrigerant circuits (oil, residues,...).
4. According to its quality, use recovered refrigerant to charge the unit or give it to refrigerant producer for recycling or elimination.

Evacuation and Dehydration

1. Disconnect ALL power before/during evacuation.
2. Connect the vacuum pump to the 5/8 " flare connection on the bottom of the evaporator and/or condenser.
3. To remove all of the moisture from the system and to insure a leak free unit, pull the system down below 500 microns.
4. After the unit is evacuated, perform a standing rise test for at least an hour. The pressure should not rise more than 150 microns. If the pressures rises more than 150 microns, either a leak is present or moisture still in the system.

Refrigerant Charging

Once the system is deemed leak and moisture free, use the 5/8 "flare connections at the bottom of the evaporator and condenser to add refrigerant charge. Refer to Table 1 and unit nameplate for refrigerant charge information.

Recommended service routine frequencies

As a commitment to our customers, we have created a wide service network staffed with experienced factory-authorized technicians. At Trane we offer all the benefits of after sales service direct from the manufacturer and we are committed to our mission statement to provide efficient customer care.

We would be delighted to discuss your individual requirement with you. For further information regarding Trane maintenance agreements please contact your local TRANE sales office.

Year	Commis- sioning	Inspec- tion visit	Seasonal shutdown & start up	Refrig- erant analysis	Annual mainte- nance	Preven- tive Main- tenance	Tube analysis (1)	Com- pressor capacitors change	Soft start fan change	Load balancing valve & economiz- er inspec- tion	Check of presence of exces- sive vibra- tion (2)	Condenser cleanless inspec- tion
1	X	X	X									
2			X		X	X				X	X	X
3			X		X	X				X	X	
4			X		X	X				X	X	X
5			X		X	X	X	X	X	X	X	
6			X	X	X	X				X	X	X
7			X		X	X				X	X	
8			X	X	X	X				X	X	X
9			X		X	X				X	X	
10			X	X	X	X	X	X	X	X	X	X
Over 10			Every year	Every 2 years	Every year		Every 3 years	Every 5 years	Every 5 years	Every year	Every year	Every 2 years

This timetable is applicable to units operating conditions with an average of 4000 hours per year. If operating conditions are abnormally severe, an individual timetable must be made for that unit

(1) Tube testing is required if aggressive water conditions exist. Applies to tube in shell exchangers

(2) Applies to vibrations source outside the compressor

Seasonal start up and shut down are mainly recommended for comfort air conditioning. Annual and preventive maintenance are mainly recommended for process application.

Additional services

Vibration analysis should be performed on a regular basis to build a vibration trend of the equipment and avoid unplanned downtime and costs.

Water treatment

This Service provides all of the necessary chemicals to properly treat each water system for the period designated.

The inspections will be conducted at agreed upon intervals and Trane Service First will submit a written report to the customer after each inspection.

These reports will indicate any corrosion, scaling, and alga growth in the system.

Refrigerant analysis

This Service includes a thorough analysis for contamination and solution upgrade.

It is recommended that this analysis be performed every six months.

Annual cooling tower maintenance

This Service includes the inspection and maintenance of the cooling tower at least once a year.

This involves checking the motor.

24 hours duty

This service includes emergency calls outside of the office normal working hours.

This Service is only available with a Maintenance Contract, where available.

Trane Select Agreements

Trane Select Agreements are programs tailored to your needs, your business and your application. They offer four different levels of coverage. From preventive maintenance plans to fully comprehensive solutions, you have the option of selecting the coverage that best suits your requirements.

Tube analysis

- Eddy Current Tube Testing for prediction of tube failure/ wear.
- Frequency - every 5 years for first 10 years (depending on the water quality), then every 3 years thereafter.



Trane offers a broad portfolio of advanced controls and HVAC systems, comprehensive building services and parts. For more information visit www.Trane.com

Trane has a policy of continuous product and product data improvement and reserves the right to change design and specifications without notice.

© 2023 Trane All rights reserved
CTV SVX011C-GB November 2023
Supersedes CTV SVX011B-GB March 2020

We are committed to using environmentally
conscious print practices that reduce waste.