



# Installation Operation Maintenance

**CGAX/CXAX 015 - 060**

Air-cooled scroll chillers and heat pumps 43-164 kW  
R410A/R454B



October 2022

**CG-SVX027E-GB**

**TRANE**  
TECHNOLOGIES

Confidential and proprietary Trane information  
Original instructions



# Table of Contents

<b>General Information.....</b>	<b>3</b>
<b>Model Number Description.....</b>	<b>5</b>
<b>Unit Description.....</b>	<b>7</b>
<b>Pre-Installation.....</b>	<b>8</b>
<b>General Data.....</b>	<b>11</b>
<b>Installation – Mechanical.....</b>	<b>19</b>
<b>Hydraulic Data.....</b>	<b>24</b>
<b>Operating Map.....</b>	<b>26</b>
<b>Partial Heat Recovery.....</b>	<b>27</b>
<b>Installation – Electrical.....</b>	<b>28</b>
<b>Electrical Data.....</b>	<b>30</b>
<b>Communication Interface Options.....</b>	<b>32</b>
<b>Operating Principles.....</b>	<b>33</b>
<b>Variable Primary Flow.....</b>	<b>40</b>
<b>Controls/Tracer TD7 Operator Interface.....</b>	<b>41</b>
<b>General Start up.....</b>	<b>42</b>
<b>Pre-Start Check List (Sample).....</b>	<b>45</b>
<b>Operation.....</b>	<b>46</b>
<b>Maintenance.....</b>	<b>47</b>
<b>Troubleshooting Guide.....</b>	<b>53</b>
<b>Notes.....</b>	<b>55</b>

# General Information

## Foreword

These instructions are given as a guide to good practice in the installation, start-up, operation, and maintenance by the user, of Trane CGAX chillers or CXAX heat pumps. They do not contain full service procedures necessary for the continued successful operation of this equipment.

The services of a qualified technician should be employed through the medium of a maintenance contract with a reputable service company. Read this manual thoroughly before unit start-up.

A separate manual is available for the use and maintenance of the unit's control, Tracer™ Symbio800.

Units are assembled, pressure tested, dehydrated, charged and tested in accordance with factory standard before shipment.

## Warnings and cautions

Warnings and Cautions appear at appropriate sections throughout this manual. Your personal safety and the proper operation of this machine require that you follow them carefully. The constructor assumes no liability for installations or servicing performed by unqualified personnel.

**WARNING!:** Indicates a potentially hazardous situation which, if not avoided, could result in death or serious injury.

**CAUTION!:** Indicates a potentially hazardous situation which, if not avoided, may result in minor or moderate injury. It may also be used to alert against unsafe practices or for equipment or property-damage only accidents.

**CAUTION!:** Time before to work on the electrical panel of the unit with Low Ambient option: once the unit is off (confirmed by the extinction of the display), it is mandatory to wait five minutes before working on the electrical panel.

## Safety recommendations

To avoid death, injury, equipment or property damage, the following recommendations should be observed during maintenance and service visits:

1. The maximum allowable pressures for system leak testing on low and high pressure side are given in the chapter "Installation". Do not exceed test pressure by using an appropriate device.
2. Disconnect the main power supply before any servicing on the unit.
3. Service work on the refrigeration system and the electrical system should be carried out only by qualified and experienced personnel.
4. Refer Addendum (PROD-SVX01) to Manuals for units with refrigerant, for conformity to the Pressure Equipment Directive (PED) 2014/68/EU, Machinery Directive 2006/42/EC, and safety recommendations.

## Reception

On arrival, inspect the unit before signing the delivery note. Specify any visible damage on the delivery note, and send a registered letter of protest to the last carrier of the goods within 7 days of delivery.

Notify the local TRANE sales office at the same time. The delivery note must be clearly signed and countersigned by the driver.

Any concealed damage shall be notified by a registered letter of protest to the last carrier of the goods within 7 days of delivery. Notify the local TRANE sales office at the same time.

Important notice: No shipping claims will be accepted by TRANE if the above mentioned procedure is not respected.

For more information, refer to the general sales conditions of your local TRANE sales office.

**Note: Unit inspection in France.**

**Delay to send registered letter in case of visible and concealed damage is only 72 hours.**

## Warranty

Warranty is based on the general terms and conditions of the manufacturer. The warranty is void if the equipment is repaired or modified without the written approval of the manufacturer, if the operating limits are exceeded or if the control system or the electrical wiring is modified. Damage due to misuse, lack of maintenance or failure to comply with the manufacturer's instructions or recommendations is not covered by the warranty obligation. If the user does not conform to the rules of this manual, it may entail cancellation of warranty and liabilities by the manufacturer.



## General Information

### Contract

It is strongly recommended that you sign a maintenance contract with your local Service Agency. This contract provides regular maintenance of your installation by a specialist in our equipment.

Regular maintenance ensures that any malfunction is detected and corrected in good time and minimizes the possibility that serious damage will occur. Finally, regular maintenance ensures the maximum operating life of your equipment.

We would remind you that failure to respect these installation and maintenance instructions may result in immediate cancellation of the warranty.

### Training

To assist you in obtaining the best use of it and maintaining it in perfect operating condition over a long period of time, the manufacturer has at your disposal a refrigeration and air conditioning service school.

The principal aim of this is to give operators and technicians a better knowledge of the equipment they are using, or that is under their charge. Emphasis is particularly given to the importance of periodic checks on the unit operating parameters as well as on preventive maintenance, which reduces the cost of owning the unit by avoiding serious and costly breakdown.

# Model Number Description

**Digit 1-4 — Chiller Model**

CGAX = Air-cooled Scroll chiller

CXAX = Air-cooled Scroll reversible chiller

**Digit 5-7 — Unit Nominal Tonnage**

015 = 15 Nominal Tons

017 = 17 Nominal Tons

020 = 20 Nominal Tons

023 = 23 Nominal Tons

026 = 26 Nominal Tons

030 = 30 Nominal Tons

035 = 35 Nominal Tons

036 = 36 Nominal Tons

039 = 39 Nominal Tons

040 = 40 Nominal Tons

045 = 45 Nominal Tons

046 = 46 Nominal Tons

052 = 52 Nominal Tons

060 = 60 Nominal Tons

**Digit 8 — Unit Voltage**

E = 400V/3ph/50Hz

G = 400 Volt 50 Hz 3 Phase Compatible With IT Neutral

**Digit 9 — Manufacturing Plant**

1 = Epinal, France

F = Epinal, France (ICS)

**Digit 10-11 — Design Sequence**

A = Factory assigned

0 = Factory assigned

**Digit 12 — Efficiency Level**

1 = Standard Efficiency (SE)

**Digit 13 — Agency Listing**

E = CE Certification

**Digit 14 — Pressure Vessel Code**

4 = Pressure Equipment Directive (PED)

**Digit 15 — Condenser Temperature Range**

A = Standard ambient (5°C/46°C)

C = Low ambient CGAX (-18°C/46°C) - CXAX cooling mode (-10°C/46°C)

**Digit 16, 17 — Open for future options****Digit 18 — Freeze Protection (Factory-Installed Only)**

X = Without freeze protection

2 = With freeze protection by heaters

3 = With freeze protection by pump activation

**Digit 19 — Open for future options****Digit 20 — Open for future options**

A = Full Factory Refrigerant charge (HFC-410A)

B = Full Factory Refrigerant charge (HFO-454B)

2 = R410A Nitrogen Charge

3 = R454B Nitrogen Charge

8 = R410A with pre-charge only (with oil)

**Digit 21 — Operating map water side**

A = Comfort cooling (5°C/20°C)

B = Process cooling (CGAX: -12°C/5°C; CXAX: -10°C/5°C)

**Digit 22 — Evaporator Water Connection**

1 = Grooved pipe

3 = Grooved pipe, couplings and pipe stub

**Digit 23 — Condenser coating**

B = Standard Aluminum Fin coil (CXAX)

E = Epoxy Aluminum Fin coil for (CXAX)

H = Microchannel (CGAX)

J = E-coated Microchannel (CGAX)

**Digit 24 — Heat Recovery**

X = Without

2 = Partial Heat Recovery

**Digit 25 — Open for future options****Digit 26 — Starter Type**

A = Across the line starter / Direct on line

B = Soft Starter

**Digit 27, 28 — Open for future options****Digit 29 — R454B Refrigerant detector**

X = Without

2 = With R454B refrigerant detector

**Digit 30 — Human Interface**

X = Without

A = With human interface

## Model Number Description

### Digit 31 — Communication Options

X = without

1 = Modbus RTU Interface

4 = BACnet MS/TP Interface

5 = ModBus TCP interface

6 = BACnet TCP/IP interface

### Digit 32 — Customer Input/Output extension module

X = None

A = With (1A4)

### Digit 33 — Chiller Smart Sequencer

X = None

### Digit 34 — Open for future options

### Digit 35 — Hydraulic module

X = No pumps and no contactors

5 = Single pump standard pressure

6 = Single pump high pressure

7 = Dual pump standard pressure

8 = Dual pump high pressure

### Digit 36 — Smart Flow Control

X = No pump flow control

B = Manual flow control

C = Variable primary Flow (constant delta T)

### Digit 37 — Buffer Tank

X = Without

1 = With Tank

### Digit 38 — Open digit for future options

### Digit 39 — Installation Accessories

1 = None

4 = Neoprene pads

### Digit 40 — Open digit for future options

### Digit 41 — Acoustical options

3 = Standard

4 = Low Noise

### Digit 42 — Condenser Protection

X = Without

A = Condenser Guard Grill

### Digit 43 — Open digit for future options

### Digit 44 — Literature language

A = Bulgarian

B = Spanish

C = German

D = English

E = French

H = Dutch

J = Italian

M = Swedish

N = Turkish

P = Polish

R = Russian

T = Czech

U = Greek

V = Portuguese

W = Slovene

Y = Romanian

Z = Norwegian

1 = Slovak

2 = Croatian

3 = Hungarian

### Digit 45 — Under/Over Voltage Protection

X = None

1 = With

### Digit 46 — Open for future options

### Digit 47 — Customer witness performance test

X = None

### Digit 48 — Open for future options

### Digit 49 — Supplementary Heat Control

X = None

### Digit 50 — Special design

X = Standard

S = Special design

# Unit Description

Conquest chillers, CGAX, air cooled scroll compressor type liquid chillers and CXAX heat pumps, are designed for outdoor installation. Units can have one or two independent refrigerant circuits, two or more compressors per circuit. Unit are packaged with an evaporator made with a braze plate heat exchanger, and one or more condenser coils.

Each unit is completely assembled, hermetic package, refrigerant circuit factory piped, electrical components wired, leak tested, dehydrated, charged and tested for proper control operations prior to shipment. The chilled water inlet and outlet openings are covered for shipment.

Units feature is Trane's exclusive Tracer™ Symbio800 Control logic and controls. It monitors the control variables that govern the operation of the unit.

A new generation of chiller control systems, providing improved control capabilities. Integrated safety protocols to protect both compressor and motor from electrical faults like thermal overload and phase reversal.

Each refrigerant circuit is provided with filter, electronic expansion valve, and charging valves.

In cooling mode on the CXAX or on the CGAX, the evaporator is a brazed plate and frame heat exchanger equipped with water drain and vent connections on the water piping.

The condenser coil is available in four different configurations: fin and tube with aluminium fins, or black epoxy pre-coating aluminum fins for the heat pump versions, and MicroChannel type or E-coating Microchannel type for the cooling only versions.

## Accessory/options information

Check all the accessories and loose parts which are shipped with the unit against the original order. Included in these items will be rigging diagrams, wiring diagrams, and service literature, which are placed inside the control panel and/or starter panel for shipment. Also check for optional components, such as couplings and pipe stubs or neoprene pads.

The following pictograms can be found on the unit. Take necessary precautions to avoid damage and injury.

Figure 1 - Warning pictograms



- 1 = Risk that unit is powered up
- 2 = Risk hazard due to fan rotation
- 3 = Risk hazard of burns on compressors or refrigeration piping
- 4 = Unit contains refrigerant gas. See specific warnings.
- 5 = Risk of residual voltage when speed drive or softstarter or Low Ambient options are present
- 6 = Unit under pressure
- 7 = Risk to cut, particularly on heat exchanger fins
- 8 = Read instructions before installation
- 9 = Disconnect all electric power before servicing
- 10 = Read technical instructions
- 11 = Valuable for unit contains a mildly flammable refrigerant R454B. Flammability risk hazard.

# Pre-Installation

## Mandatory Start-up Checklist

This checklist is not intended to be a substitution for the contractor's installation instruction. This checklist is intended to be a guide for the Trane technician just prior to unit 'start-up'. Many of the recommended checks and actions could expose the technician to electrical and mechanical hazards. Refer to the appropriate sections in the unit manual (Addendum\_PROD-SVX01 latest version) for appropriate procedures, component specifications and safety instructions.

Except where noted; it is implied that the technician is to use this checklist for inspection / verification of prior task completed by the general contractor at installation.

1. Unit clearances adequate for service and to avoid air recirculation, etc.
2. Unit exterior inspected. CXAX condenser coil will not be obstructed at any time by snow or ice during winter conditions.
3. Unit properly grounded
4. **Crankcase heaters working for 24 hours prior to arrival of Trane technician performing start up**
5. Correct voltage supplied to unit and electric heaters (imbalance not to exceed 2%)
6. Unit power phasing (A-B-C sequence) proper for compressor rotation
7. Copper power wiring meets sizing requirement in job submittal
8. All automation and remote controls installed/wired
9. All wiring connections tight
10. Prove chilled water side Interlock and Interconnecting Wiring Interlock and externals (chilled water pump)
11. Field installed control wiring landed on correct terminals (external start/stop, emergency stop, chilled water reset...)
12. Verify all refrigerant and oil valves are open/back seated
13. Compressor oil levels (1/2 -3/4 high in glass) proper
14. Verify chilled water strainer is clean and free of debris and evaporator chilled water circuits are filled
15. A pressure switch device to detect lack of water is not included in the pump package. Installation of this type of device is highly recommended to avoid sealing damage due to operation of pump without enough water.
16. Close the fused-disconnect switches that supplies power to the chilled water pump starter
17. Start the chilled water pump to begin circulation of the water. Inspect piping for leaks and repair as necessary. Check the physical presence of the water pressure switch.
18. With water circulating through the system, adjust water flow and check water pressure drop through evaporator
19. Return chilled water pump to auto
20. Verify all the chiller controller Menu Items.
21. All panels/doors secured prior to start-up
22. All coil fins inspected and straightened
23. Rotate fans before starting unit to inspect for potential audible and visual signs of rubbing. Start unit
24. Press AUTO key. The unit will start if the chiller control calls for cooling and the safety interlocks are closed
25. Check the evaporator and the condenser refrigerant pressure on the chiller controller.
26. Confirm Superheat and subcooling values are normal
27. Compressor operation normal and within amperage rating
28. Operating log completed
29. Press stop key
30. Inspect fans again after being under load to ensure no signs or rubbing exist
31. Verify the chilled water pump runs for at least 1 minute (possibility to configure maxi 10 mn) after the chiller is commanded to stop (for normal chilled water systems)

## Unit storage

If the chiller is to be stored for more than one month prior to installation, observe the following precautions:

- Store the chiller in a dry, vibration-free, secure area.
- Units charged with refrigerant should not be stored where temperatures exceed 68°C.
- At least every three months, attach a gauge and manually check the pressure in the refrigerant circuit. If the refrigerant pressure is below 13 bar at 20°C (or 10 bar at 10°C), call a qualified service organization and the appropriate Trane sales office.
- If the refrigerant pressure is below 13 bar (R410A) / 12.5 bar (R454B) at 20°C or 10 bar (R410A) / 9.5 bar (R454B) at 10°C, call a qualified service organization or Trane Sales Office.

The Trane Company will not assume responsibility for equipment damage resulting from accumulation of condensate on the unit electrical components.

**Note:** if the unit is stored before servicing near a construction site it is highly recommended to protect micro channel coils from any concrete and iron element. Failure to do so may considerably reduce reliability of the unit.



## Pre-Installation

### Installation requirements and contractor responsibilities

A list of the contractor responsibilities typically associated with the unit installation process is provided.

Type of requirement	Trane factory Supplied	Trane factory Supplied	Field supplied
	Trane factory Installed	Field Installed	Field installed
Foundation			Meet foundation requirements
Rigging			<ul style="list-style-type: none"> <li>Safety chains</li> <li>Clevis connectors</li> <li>Lifting beams</li> </ul>
Isolation		Neoprene pads (Optional)	Isolators (customer supplied)
Electrical	<ul style="list-style-type: none"> <li>Disconnect Switch</li> <li>Unit mounted starter</li> </ul>		<ul style="list-style-type: none"> <li>Wiring sizes per submittals and local codes and regulations</li> <li>Terminal lugs</li> <li>Control voltage wiring</li> <li>Ground connection(s)</li> <li>BAS Wiring (optional)</li> <li>Chilled water pump contactor and wiring including interlock</li> <li>Option relays and wiring</li> </ul>
Water piping			<ul style="list-style-type: none"> <li>Taps for thermometers and gauges</li> <li>Thermometers</li> <li>Water flow pressure gauges</li> <li>Isolation and balancing valves in water piping</li> <li>Vents and rains</li> <li>Pressure relief valves</li> <li>Pressure switch device to detect lack of water</li> </ul>
Insulation	<ul style="list-style-type: none"> <li>Insulation</li> </ul>		<ul style="list-style-type: none"> <li>Insulation (piping)</li> </ul>
Water piping connection elements	<ul style="list-style-type: none"> <li>Grooved pipe</li> </ul>	<ul style="list-style-type: none"> <li>Grooved pipes coupling and stub pipe (Optional)</li> </ul>	

### Refrigerant leak detector R454B

Refrigerant leak detector R454B is an option available only for R454B units. It is installed in the factory and set according to the critical thresholds but it is not wired.

There are two relays available: Relay 1 for warning message and Relay 3 for critical message. When warning or critical levels of R454B concentrations are reached, customer has to shutdown the electrical power to the unit.

It is needed to use a disconnect switch upstream from the unit, operated remotely, that will open electric circuit to the unit when there is a refrigerant leakage. Please consult wiring diagrams regarding to the relay's connection. The refrigerant detector is identified as 3A6.

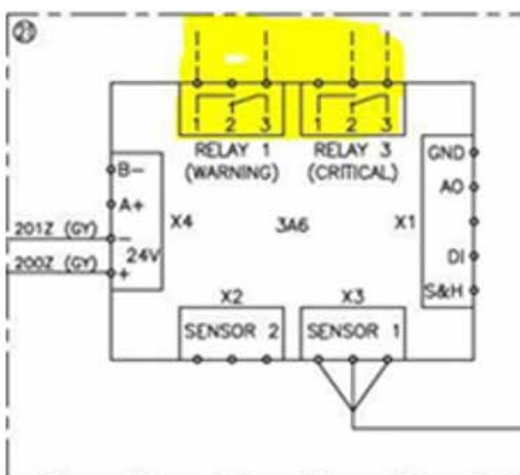

## Pre-Installation

The sensor is set to LFL (Lower Flammable Limit) about 0.5 % (500 ppm) at 23°C ambient temperature and RH 50%. Value of LFL is not adjustable.



The detector is installed in the interior part close to the brazed plate heat exchanger.

### Simplex units:

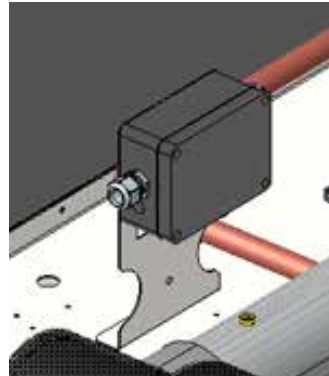
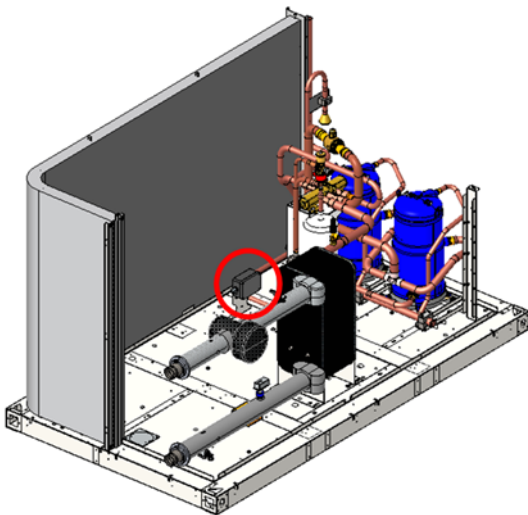

### Duplex units:

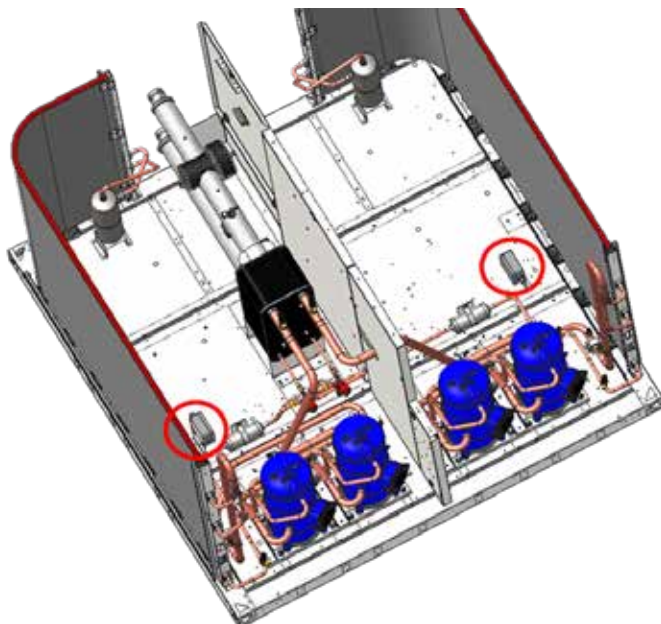

# General Data

**Table 1 - CGAX 015-035 General Data**

		CGAX 015 SE-SN	CGAX 017 SE-SN	CGAX 020 SE-SN	CGAX 023 SE-SN	CGAX 026 SE-SN	CGAX 030 SE-SN	CGAX 035 SE-SN
Net Cooling Capacity R410A (1)	(kW)	44.8	50.7	59.9	66.8	75.7	83.6	100.0
Total Power input in cooling R410A (1)	(kW)	14.8	17.4	19.0	22.2	25.8	29.3	35.3
Net cooling capacity R454B (1)	(kW)	40.9	48.4	56.4	63.7	74.6	81.8	100.4
Total Power input in cooling R454B (1)	(kW)	14.6	17.3	18.1	21.1	24.5	28	33.6
<b>Unit electrical data (2) (3) (4)</b>								
Short Circuit Unit Capacity (9)	(kA)	12	12	12	12	12	12	15
Power Cable Cross Section (max)	mm <sup>2</sup>	35	35	35	35	35	35	150
Disconnect switch size	(A)	80	80	100	100	100	100	250
<b>Digit 12=1 and Digit 15=A</b>								
Maximum Power input	(kW)	19.4	22.1	25.8	29.5	33.3	37.0	44.2
Unit rated amps	(A)	33.8	38.5	45.4	50.5	55.6	64.0	76.5
Unit start up amps (w/o soft starter - Digit 26=A) (4)	(A)	116.3	160.3	167.2	183.2	188.3	189.5	198.3
Unit start up amps (with soft starter - Digit 26=B) (4)		77.1	103.5	110.4	120.0	125.1	127.5	141.5
Power factor		0.845	0.846	0.836	0.861	0.880	0.847	0.846
<b>Digit 12=1 and Digit 15=C</b>								
Maximum Power input	(kW)	20.4	23.2	26.8	30.6	34.3	38.1	46.4
Unit rated amps	(A)	34.5	39.2	46.2	51.3	56.4	64.8	78.1
Unit start up amps (w/o soft starter - Digit 26=A) (4)	(A)	117.0	161.0	168.0	184.0	189.1	190.3	199.9
Unit start up amps (with soft starter - Digit 26=B) (4)		77.8	104.2	111.2	120.8	125.9	128.3	143.1
Power factor		0.868	0.866	0.854	0.875	0.892	0.859	0.866
<b>Compressor</b>								
Compressor Number per Circuit	#	2	2	2	2	2	2	2
Type		Scroll	Scroll	Scroll	Scroll	Scroll	Scroll	Scroll
Model Circuit1 / Circuit 2		7.5+7.5	7.5+10	10+10	10+13	13+13	15+15	7.5+10 / 7.5+10
Max Compr Power input Circuit 1/Circuit 2	kW	9.2+9.2	9.2+12	12+12	12+15.7	15.7+15.7	17.61+17.6	9.2+12 / 9.2+12
Rated Amps Circuit1 / Circuit 2 (4)	(A)	15.5+15.5	15.5+20.2	20.2+20.2	20.2+25.3	25.3+25.3	29.5+29.5	15.5+20.2 / 15.5+20.2
Locked Rotor Amps Circuit1 / Circuit 2 (4)	(A)	98+98	98+142	142+142	142+158	158+158	155+155	98+142 / 98+142
Motor RPM	(rpm)	2900	2900	2900	2900	2900	2900	2900
Oil sump heater Circuit1 / Circuit 2	(W)	0.17 / 0	0.17 / 0	0.17 / 0	0.17 / 0	0.17 / 0	0.17 / 0	0.17 / 0.17
<b>Evaporator</b>								
Quantity	#	1	1	1	1	1	1	1
Type		Stainless steel Copper Brazed plate Heat exchanger						
Evaporator model		P80x66	P80x92	P80x92	P80x92	P120Tx76	P120Tx76	DP300x82
Evaporator Water Content volume	(l)	3.8	5.3	5.3	5.3	9.2	9.2	8.5
Nominal water connection size (Grooved coupling) - Without HYM	(in) - (mm)	2" - 60.3	2" - 60.3	2" - 60.3	2" - 60.3	2" - 60.3	2" - 60.3	3" OD - 76.1
Nominal water connection size (Grooved coupling) - With HYM	(in) - (mm)	2" - 60.3	2" - 60.3	2" - 60.3	2" - 60.3	2" - 60.3	2" - 60.3	3" OD - 76.1
<b>Hydraulic Module Components</b>								
<b>Single pump - Standard head pressure option</b>								
Max available Head Pressure	(kPa)	96	100	86	113	120	110	111
Motor Power	(kW)	1.20	1.20	1.20	1.50	1.50	1.50	1.50
Rated Amps	(A)	2.44	2.44	2.44	3.50	3.50	3.50	3.50
<b>Single pump - High head pressure option</b>								
Max available Head Pressure	(kPa)	170	174	162	152	161	152	151
Motor Power	(kW)	2.30	2.30	2.30	2.30	2.30	2.30	3.00
Rated Amps	(A)	5.03	5.03	5.03	5.03	5.03	5.03	6.23
<b>Twin pump - Standard head pressure option</b>								
Max available Head Pressure	(kPa)	96	100	86	113	120	110	111
Motor Power	(kW)	1.20	1.20	1.20	1.50	1.50	1.50	1.50
Rated Amps	(A)	2.44	2.44	2.44	3.50	3.50	3.50	3.50
<b>Twin pump - High head pressure option</b>								
Max available Head Pressure	(kPa)	170	174	162	152	161	152	198
Motor Power	(kW)	2.30	2.30	2.30	2.30	2.30	2.30	3.00
Rated Amps	(A)	5.03	5.03	5.03	5.03	5.03	5.03	6.23
Expansion Tank Volume	(l)	25	25	25	25	25	25	35
Max User water loop Volume for factory mounted expansion tank (1)	(l)	1450	1450	1450	1450	1450	1450	2000
Optionnal water Buffer tank volume	(l)	324	324	324	324	324	324	444
Antifreeze Heater without pump package	(W)	120	120	120	120	120	120	120
Antifreeze Heater with pump package	(W)	280	280	280	280	280	280	280
<b>Condenser</b>								
Type		Full aluminum Micro channel heat exchanger						
Quantity of coil	#	1	1	1	1	1	1	2
Face area per circuit	(m <sup>2</sup> )	2.23	2.23	2.96	2.96	2.96	2.96	2.96

## General Data

**Table 1 - CGAX 015-035 General Data (continued)**

		CGAX 015 SE-SN	CGAX 017 SE-SN	CGAX 020 SE-SN	CGAX 023 SE-SN	CGAX 026 SE-SN	CGAX 030 SE-SN	CGAX 035 SE-SN
<b>Condenser Fan</b>								
Quantity	#	1	1	2	2	2	2	2
Diameter	(mm)	800						
Fan / motor Type		Propeller axial fan						
<b>Digit 12=1 and Digit 15=A</b>								
Fan / motor Type		Fixed speed AC motor						
Airflow per fan	m <sup>3</sup> /h	13788	13828	12362	12362	12370	12375	14687
Max Power Input	Kw	0.89	0.89	0.89 + 0.89	0.89 + 0.89	0.89 + 0.89	0.89 + 0.89	0.89 / 0.89 + 0
Max Amps	A	2.22	2.22	2.22 + 2.22	2.22 + 2.22	2.22 + 2.22	2.22 + 2.22	2.22 / 2.22 + 0
Motor RPM	(rpm)	686	686	686	686	686	686	686
<b>Digit 12=1 and Digit 15=C</b>								
Fan / motor Type		Fixed speed AC motor / Variable speed						
Airflow per fan	m <sup>3</sup> /h	13788	13828	12362	12362	12370	12375	14687
Max Power Input	Kw	1.95	1.95	1.95 + 0.89	1.95 + 0.89	1.95 + 0.89	1.95 + 0.89	1.95 / 1.95 + 0
Max Amps	A	3	3	3 + 2.22	3 + 2.22	3 + 2.22	3 + 2.22	3 / 3 + 0
Motor RPM	(rpm)	686	686	686	686	686	686	686
Airflow per Fan	(m <sup>3</sup> /h)	13788	13828	12362	12362	12370	12375	14687
Power per Motor	(kW)	686	686	686	686	686	686	686
<b>Partial Heat recovery (PHR) option</b>								
Heat-Exchanger Type		Stainless steel Copper Brazed plate Heat exchanger						
Heat-Exchanger Model		B3-014-14- 4.5M	B3-014-14- 4.5M	B3-014-14- 4.5M	B3-014-14- 4.5M	B3-027-14- 4.5L	B3-027-14- 4.5L	2x B3-014- 14-4.5M
Water connection size (Thread connection)	(in) - (mm)	G 1"1/4 (31.75 mm)	G 1"1/4 (31.75 mm)	G 1"1/4 (31.75 mm)	G 1"1/4 (31.75 mm)	G 1"1/4 (31.75 mm)	G 1"1/4 (31.75 mm)	G 1"1/4 (31.75 mm)
Water content volume	(l)	0.14	0.14	0.14	0.14	0.35	0.35	2x 0.14
<b>Dimensions (7)</b>								
Unit Length	(mm)	2346	2346	2346	2346	2346	2346	2327
Unit Width	(mm)	1285	1285	1285	1285	1285	1285	2250
Std Unit Height	(mm)	1524	1524	1524	1524	1524	1524	1524
LN or External SP unit - (Additional height configuration)	(mm)	+223	+224	+225	+226	+227	+228	+232
Water Buffer tank option - (Additional height configuration)	(mm)	+330	+330	+330	+330	+330	+330	+330
<b>Weights</b>								
Shipping Weight (3)	(kg)	519	531	574	579	608	621	917
Operating Weight (3)	(kg)	497	509	552	557	587	599	887
<b>Option Additional shipping weight</b>								
Single pump - Standard head pressure	(kg)	46	46	46	49	49	49	45
Single pump - High head pressure	(kg)	51	51	51	51	51	51	49
Twin pump - Standard head pressure	(kg)	70	70	70	75	75	75	75
Twin pump - High head pressure	(kg)	82	82	82	82	82	82	84
Pump VFD option	(kg)	0						
<b>Partial heat recovery option</b>	(kg)	1.48	1.48	1.48	1.48	3.82	3.82	2x 1.48
Water Buffer tank option	(kg)	319	319	319	319	319	319	425
<b>System data</b>								
Nb of refrigerant circuit	#	1	1	1	1	1	1	2
Minimum cooling load % (6)	%	50	43	50	43	50	50	22
<b>Standard/Partial Heat Recovery Unit unit</b>								
R410A refrigerant charge Circuit1 / Circuit 2	(kg)	7.5	9.0	9.0	9.0	10.5	10.5	8
R454B refrigerant charge Circuit1 / Circuit 2	(kg)	6.0	7.0	7.0	7.0	8.5	8.5	6.5
Oil charge Circuit1 / Circuit 2 R410A & R454B	(l)	6.0	6.3	6.6	6.6	6.6	7.2	6.3
POE Oil type (6)		OIL058E / OIL057E						

- (1) Indicative performance at Evaporator water temperature : 12°C / 7°C - Condenser air temperature 35°C - for detailed performances, on a given unit, consult Order Write Up.
- (2) under 400V/3/50Hz.
- (3) Rated Condition without Pump Package.
- (4) Electrical & system data are indicative and subject to change without notice. Please refer to unit nameplate data.
- (5) If the power line of the unit is protected by fuses gG of the same size as the disconnect switch.
- (6) OIL058E or OIL057E are European reference for POE oil and can be mixed in any proportion with OIL00078 or OIL 00080 (same oil with US reference on compressor nameplate).
- (7) For dimensions details, dimensions of hydraulic connections, electrical connections, point load and specific features for heat recovery see submittals and diagrams which are supplied with every order.

## General Data

**Table 2 - CGAX 036-060 General Data**

		CGAX 036 SE-SN	CGAX 039 SE-SN	CGAX 040 SE-SN	CGAX 045 SE-SN	CGAX 046 SE-SN	CGAX 052 SE-SN	CGAX 060 SE-SN
Net Cooling Capacity R410A (1)	(kW)	100.6	113.6	117.9	129.3	132.5	148.9	164.9
Total Power input in cooling R410A (1)	(kW)	33.2	38.1	39.6	41.7	46.8	51.3	58.0
Net cooling capacity R454B (1)	(kW)	96.7	109.4	116.1	122.8	131.4	150.5	164.7
Total Power input in cooling R454B (1)	(kW)	33	37.5	36.2	40.3	42.2	48.4	55.5
<b>Unit electrical data (2) (3) (4)</b>								
Short Circuit Unit Capacity (9)	(kA)	15	15	15	15	15	15	15
Power Cable Cross Section (max)	mm <sup>2</sup>	150	150	150	150	150	150	150
Disconnect switch size	(A)	250	250	250	250	250	250	250
<b>Digit 12=1 and Digit 15=A</b>								
Maximum Power input	(kW)	43.0	49.0	51.6	55.5	59.0	66.5	74.0
Unit rated amps	(A)	73.8	81.0	90.4	95.8	100.6	110.8	127.6
Unit start up amps (w/o soft starter - Digit 26=A) (4)	(A)	197.9	213.7	212.2	221.3	233.3	243.5	253.1
Unit start up amps (with soft starter - Digit 26=B) (4)		139.1	150.5	155.4	159.3	170.1	180.3	191.1
Power factor		0.854	0.886	0.836	0.847	0.861	0.880	0.847
<b>Digit 12=1 and Digit 15=C</b>								
Maximum Power input	(kW)	44.1	50.0	53.7	56.6	61.2	68.6	76.1
Unit rated amps	(A)	74.6	81.8	91.9	96.6	102.1	112.3	129.1
Unit start up amps (w/o soft starter - Digit 26=A) (4)	(A)	198.7	214.5	213.7	222.1	234.8	245.0	254.6
Unit start up amps (with soft starter - Digit 26=B) (4)		139.9	151.3	156.9	160.1	171.6	181.8	192.6
Power factor		0.864	0.894	0.854	0.855	0.875	0.892	0.859
<b>Compressor</b>								
Compressor Number per Circuit	#	3	3	2	3	2	2	2
Type		Scroll	Scroll	Scroll	Scroll	Scroll	Scroll	Scroll
Model Circuit1 / Circuit 2		12+12+12	13+13+13	10+10 / 10+10	15+15+15	10+13 /10+13	13+13 / 13+13	15+15 / 15+15
Max Compr Power input Circuit 1/Circuit 2	kW	13,7 + 13,7 + 13,7	15,7 + 15,7 + 15,7	12 + 12 / 12 + 12	17,6 + 17,6 + 17,6	12 + 15,7 / 12 + 15,7	15,7 + 15,7 / 15,7 + 15,7	17,6 + 17,6 / 17,6 + 17,6
Rated Amps Circuit1 / Circuit 2 (4)	(A)	22,9 + 22,9 + 22,9	25,3 + 25,3 + 25,3	20,2 + 20,2 / 20,2 + 20,2	29,5 + 29,5 + 29,5	20,2 + 25,3 / 20,2 + 25,3	25,3 + 25,3 / 25,3 + 25,3	29,5 + 29,5 / 29,5 + 29,5
Locked Rotor Amps Circuit1 / Circuit 2 (4)	(A)	147 + 147 + 147	158 + 158 + 158	142 + 142 / 142 + 142	155 + 155 + 155	142 + 158 / 142 + 158	158 + 158 / 158 + 158	155 + 155 / 155 + 155
Motor RPM	(rpm)	2900	2900	2900	2900	2900	2900	2900
Oil sump heater Circuit1 / Circuit 2	(W)	0,25 / 0	0,25 / 0	0,17 / 0,17	0,25 / 0	0,17 / 0,17	0,17 / 0,17	0,17 / 0,17
<b>Evaporator</b>								
Quantity	#	1	1	1	1	1	1	1
Type		Stainless steel Copper Brazed plate Heat exchanger						
Evaporator model		P120Tx104	P120Tx104	DP300x82	P120Tx104	DP300x82	DP300x114	DP300x114
Evaporator Water Content volume	(l)	12.5	12.5	8.5	12.5	8.5	11.8	11.8
Nominal water connection size (Grooved coupling) - Without HYM	(in) - (mm)	2" - 60,3	2" - 60,3	3" OD - 76,1	2" - 60,3	3" OD - 76,1	3" OD - 76,1	3" OD - 76,1
Nominal water connection size (Grooved coupling) - With HYM	(in) - (mm)	3" OD - 76,1	3" OD - 76,1	3" OD - 76,1	3" OD - 76,1	3" OD - 76,1	3" OD - 76,1	3" OD - 76,1
<b>Hydraulic Module Components</b>								
<b>Single pump - Standard head pressure option</b>								
Max available Head Pressure	(kPa)	103	131	133	104	114	113	178
Motor Power	(kW)	1.50	2.30	2.30	2.30	2.30	2.30	2.30
Rated Amps	(A)	3.50	5.03	5.03	5.03	5.03	5.03	5.03
<b>Single pump - High head pressure option</b>								
Max available Head Pressure	(kPa)	190	176	179	151	162	162	138
Motor Power	(kW)	3.00	3.00	3.00	3.00	3.00	3.00	3.00
Rated Amps	(A)	6.23	6.23	6.23	6.23	6.23	6.23	6.23
<b>Twin pump - Standard head pressure option</b>								
Max available Head Pressure	(kPa)	103	131	133	104	114	113	178
Motor Power	(kW)	1.50	2.30	2.30	2.30	2.30	2.30	2.30
Rated Amps	(A)	3.50	5.03	5.03	5.03	5.03	5.03	5.03
<b>Twin pump - High head pressure option</b>								
Max available Head Pressure	(kPa)	190	176	179	151	162	162	138
Motor Power	(kW)	3.00	3.00	3.00	3.00	3.00	3.00	3.00
Rated Amps	(A)	6.23	6.23	6.23	6.23	6.23	6.23	6.23
Expansion Tank Volume	(l)	35	35	35	35	35	35	35
Max User water loop Volume for factory mounted expansion tank (1)	(l)	2000	2000	2000	2000	2000	2000	2000
Optionnal water Buffer tank volume	(l)	444	444	444	444	444	444	444
Antifreeze Heater without pump package	(W)	180	180	120	180	120	180	180
Antifreeze Heater with pump package	(W)	340	340	280	340	280	340	340
<b>Condenser</b>								
Type		Full aluminum Micro channel heat exchanger						
Quantity of coil	#	2	2	2	2	2	2	2
Face area per circuit	(m <sup>2</sup> )	4.46	5.93	2.96	5.93	2.96	2.96	2.96



## General Data

Table 2 - CGAX 036-060 General Data (continued)

		CGAX 036 SE-SN	CGAX 039 SE-SN	CGAX 040 SE-SN	CGAX 045 SE-SN	CGAX 046 SE-SN	CGAX 052 SE-SN	CGAX 060 SE-SN
<b>Condenser Fan</b>								
Quantity	#	2	2	4	3	4	4	4
Diameter	(mm)	800						
Fan Type		Propeller axial fan						
<b>Digit 12=1 and Digit 15=A</b>								
Fan / motor Type		Fixed speed AC motor						
Airflow per fan	m <sup>3</sup> /h	13827	14690	12358	13676	12363	12592	12374
Max Power Input	Kw	0,89 + 0,89	0,89 + 0,89	0,89 + 0,89 / 0,89 + 0,89	0,89 + 0,89 + 0,89	0,89 + 0,89 / 0,89 + 0,89	0,89 + 0,89 / 0,89 + 0,89	0,89 + 0,89 / 0,89 + 0,89
Max Amps	A	2,22 + 2,22	2,22 + 2,22	2,22 + 2,22 / 2,22 + 2,22	2,22 + 2,22 + 2,22	2,22 + 2,22 / 2,22 + 2,22	2,22 + 2,22 / 2,22 + 2,22	2,22 + 2,22 / 2,22 + 2,22
Motor RPM	(rpm)	686	686	686	686	686	686	686
<b>Digit 12=1 and Digit 15=C</b>								
Fan / motor Type		Fixed speed AC motor / Variable speed						
Airflow per fan	m <sup>3</sup> /h	13827	14690	12358	13676	12363	12592	12374
Max Power Input	Kw	1,95 + 0,89	1,95 + 0,89	1,95 + 0,89 / 1,95 + 0,89	1,95 + 0,89 + 0,89	1,95 + 0,89 / 1,95 + 0,89	1,95 + 0,89 / 1,95 + 0,89	1,95 + 0,89 / 1,95 + 0,89
Max Amps	A	3 + 2,22	3 + 2,22	3 + 2,22 / 3 + 2,22	3 + 2,22 + 2,22	3 + 2,22 / 3 + 2,22	3 + 2,22 / 3 + 2,22	3 + 2,22 / 3 + 2,22
Motor RPM	(rpm)	686	686	686	686	686	686	686
Airflow per Fan	(m <sup>3</sup> /h)	13827	14690	12358	13676	12363	12592	12374
Power per Motor	(kW)	686	686	686	686	686	686	686
<b>Partial Heat recovery (PHR) option</b>								
Heat-Exchanger Type		Stainless steel Copper Brazed plate Heat exchanger						
Heat-Exchanger Model		B3-027-14- 4.5L	B3-027-20- 4.5L	2x B3-014- 14-4.5M	B3-027-20- 4.5L	2x B3-014- 14-4.5M	2x B3-027- 14-4.5L	2x B3-027- 14-4.5L
Water connection size (Thread connection)	(in) - (mm)	G 1"1/4 (31.75 mm)	G 1"1/4 (31.75 mm)	G 1"1/4 (31.75 mm)	G 1"1/4 (31.75 mm)	G 1"1/4 (31.75 mm)	G 1"1/4 (31.75 mm)	G 1"1/4 (31.75 mm)
Water content volume	(l)	0.35	0.5	2x 0.14	0.5	2x 0.14	2x 0.35	2x 0.35
<b>Dimensions (7)</b>								
Unit Length	(mm)	2327	2327	2327	2327	2327	2327	2327
Unit Width	(mm)	2250	2250	2250	2250	2250	2250	2250
Std Unit Height	(mm)	1524	1524	1524	1524	1524	1524	1524
LN or External SP unit - (Additional height configuration)	(mm)	+229	+230	+233	+231	+234	+235	+236
Water Buffer tank option - (Additional height configuration)	(mm)	+330	+330	+330	+330	+330	+330	+330
<b>Weights</b>								
Shipping Weight (3)	(kg)	853	858	1004	912	1014	1034	1060
Operating Weight (3)	(kg)	819	824	973	879	983	1004	1029
<b>Option Additional shipping weight</b>								
Single pump - Standard head pressure	(kg)	45	47	47	47	47	47	47
Single pump - High head pressure	(kg)	49	49	49	49	49	49	49
Twin pump - Standard head pressure	(kg)	71	75	75	75	75	75	75
Twin pump - High head pressure	(kg)	86	86	84	86	84	84	84
Pump VFD option	(kg)							0
<b>Partial heat recovery option</b>	(kg)	3.82	4.6	2x 1.48	4.6	2x 1.48	2x 3.82	2x 3.82
Water Buffer tank option	(kg)	425	425	425	425	425	425	425
<b>System data</b>								
Nb of refrigerant circuit	#	1	1	2	1	2	2	2
Minimum cooling load % (6)	%	33	33	25	33	22	25	25
<b>Standard/Partial Heat Recovery Unit unit</b>								
R410A refrigerant charge Circuit1 / Circuit 2	(kg)	14.0	14.5	8	15.0	8	9	9.5
R454B refrigerant charge Circuit1 / Circuit 2	(kg)	11.0	11.5	6.5	12.0	6.5	7	8
Oil charge Circuit1 / Circuit 2 R410A & R454B	(l)	10.5	10.5	6.6	11.5	6.6	6.6	7.2
POE Oil type (6)		OIL058E / OIL057E						

- (1) Indicative performance at Evaporator water temperature : 12°C / 7°C - Condenser air temperature 35°C - for detailed performances, on a given unit, consult Order Write Up.
- (2) under 400V/3/50Hz.
- (3) Rated Condition without Pump Package.
- (4) Electrical & system data are indicative and subject to change without notice. Please refer to unit nameplate data.
- (5) If the power line of the unit is protected by fuses gG of the same size as the disconnect switch.
- (6) OIL058E or OIL057E are European reference for POE oil and can be mixed in any proportion with OIL00078 or OIL 00080 (same oil with US reference on compressor nameplate).
- (7) For dimensions details, dimensions of hydraulic connections, electrical connections, point load and specific features for heat recovery see submittals and diagrams which are supplied with every order.

## General Data

**Table 3 - CXAX 015-035 General Data**

		CXAX 015 SE-SN	CXAX 017 SE-SN	CXAX 020 SE-SN	CXAX 023 SE-SN	CXAX 026 SE-SN	CXAX 030 SE-SN	CXAX 035 SE-SN
Net cooling capacity R410a (1)	(kW)	43.5	49.7	59.5	66.2	72.6	79.8	97.5
Total Power input in cooling R410a (1)	(kW)	14.4	16.7	18.9	22.4	25.7	28.5	33.3
Net cooling capacity R454B (1)	(kW)	41.3	47.5	54.9	61.9	68.4	77.2	94.5
Total Power input in cooling R454B (1)	(kW)	14.1	16.0	18.6	20.2	22.5	25.0	31.5
<b>Unit electrical data (2) (3) (4)</b>								
Short Circuit Unit Capacity (9)	(kA)	12	12	12	12	12	12	15
Power Cable Cross Section (max)	mm <sup>2</sup>	35	35	35	35	35	35	150
Disconnect switch size	(A)	80	80	100	100	100	100	250
<b>Digit 12=1 and Digit 15=A</b>								
Maximum Power input	(kW)	19.4	22.1	25.8	29.5	33.3	37.0	44.2
Unit rated amps	(A)	33.8	38.5	45.4	50.5	55.6	64.0	76.5
Unit start up amps (w/o soft starter - Digit 26=A) (4)	(A)	116.3	160.3	167.2	183.2	188.3	189.5	198.3
Unit start up amps (with soft starter - Digit 26=B) (4)	(A)	77.1	103.5	110.4	120.0	125.1	127.5	141.5
Power factor		0.845	0.846	0.836	0.861	0.880	0.847	0.846
<b>Digit 12=1 and Digit 15=C</b>								
Maximum Power input	(kW)	20.4	23.2	26.8	30.6	34.3	38.1	46.4
Unit rated amps	(A)	34.5	39.2	46.2	51.3	56.4	64.8	78.1
Unit start up amps (w/o soft starter - Digit 26=A) (4)	(A)	117.0	161.0	168.0	184.0	189.1	190.3	199.9
Unit start up amps (with soft starter - Digit 26=B) (4)	(A)	77.8	104.2	111.2	120.8	125.9	128.3	143.1
Power factor		0.868	0.866	0.854	0.875	0.892	0.859	0.866
<b>Compressor</b>								
Compressor Number per Circuit	#	2	2	2	2	2	2	2
Type		Scroll	Scroll	Scroll	Scroll	Scroll	Scroll	Scroll
Model Circuit1 / Circuit 2		7,5+7,5	7,5+10	10+10	10+13	13+13	15+15	7,5+10 / 7,5+10
Max Compr Power input Circuit 1/Circuit 2	kW	9,2 + 9,2	9,2+ 12	12 + 12	12 + 15,7	15,7 + 15,7	17,61 + 17,6	9,2 + 12 / 9,2 + 12
Rated Amps Circuit1 / Circuit 2 (4)	(A)	15,5 + 15,5	15,5 + 20,2	20,2 + 20,2	20,2 + 25,3	25,3 + 25,3	29,5 + 29,5	15,5 + 20,2 / 15,5 + 20,2
Locked Rotor Amps Circuit1 / Circuit 2 (4)	(A)	98 + 98	98 + 142	142 + 142	142 + 158	158 + 158	155 + 155	98 + 142 / 98 + 142
Motor RPM	(rpm)	2900	2900	2900	2900	2900	2900	2900
Oil sump heater Circuit1 / Circuit 2	(W)	0,17 / 0	0,17 / 0	0,17 / 0	0,17 / 0	0,17 / 0	0,17 / 0	0,17 / 0,17
<b>Evaporator</b>								
Quantity	#	1	1	1	1	1	1	1
Type		Stainless steel Copper Brazed plate Heat exchanger						
Evaporator model		P80x66	P80x92	P80x92	P80x92	P120Tx76	P120Tx76	DP300x82
Evaporator Water Content volume	(l)	3.8	5.3	5.3	5.3	9.2	9.2	8.5
Nominal water connection size (Grooved coupling) - Without HYM	(in) - (mm)	2" - 60,3	2" - 60,3	2" - 60,3	2" - 60,3	2" - 60,3	2" - 60,3	3" OD - 76,1
Nominal water connection size (Grooved coupling) - With HYM	(in) - (mm)	2" - 60,3	2" - 60,3	2" - 60,3	2" - 60,3	2" - 60,3	2" - 60,3	3" OD - 76,1
<b>Hydraulic Module Components</b>								
<b>Single pump - Standard head pressure option</b>								
Max available Head Pressure	(kPa)	96	100	86	113	120	110	111
Motor Power	(kW)	1.20	1.20	1.20	1.50	1.50	1.50	1.50
Rated Amps	(A)	2.44	2.44	2.44	3.50	3.50	3.50	3.50
<b>Single pump - High head pressure option</b>								
Max available Head Pressure	(kPa)	170	174	162	152	161	152	198
Motor Power	(kW)	2.30	2.30	2.30	2.30	2.30	2.30	3.00
Rated Amps	(A)	5.03	5.03	5.03	5.03	5.03	5.03	6.23
<b>Twin pump - Standard head pressure option</b>								
Max available Head Pressure	(kPa)	96	100	86	113	120	110	111
Motor Power	(kW)	1.20	1.20	1.20	1.50	1.50	1.50	1.50
Rated Amps	(A)	2.44	2.44	2.44	3.50	3.50	3.50	3.50
<b>Twin pump - High head pressure option</b>								
Max available Head Pressure	(kPa)	170	174	162	152	161	152	198
Motor Power	(kW)	2.30	2.30	2.30	2.30	2.30	2.30	3.00
Rated Amps	(A)	5.03	5.03	5.03	5.03	5.03	5.03	6.23
Expansion Tank Volume	(l)	25	25	25	25	25	25	35
Max User water loop Volume for factory mounted expansion tank (1)	(l)	1450	1450	1450	1450	1450	1450	2000
Optionnal water Buffer tank volume	(l)	324	324	324	324	324	324	444
Antifreeze Heater without pump package	(W)	120	120	120	120	120	120	120
Antifreeze Heater with pump package	(W)	280	280	280	280	280	280	280
<b>Condenser</b>								
Type		Full aluminum Micro channel heat exchanger						
Quantity of coil	#	1	1	1	1	1	1	2
Face area per circuit	(m <sup>2</sup> )	2.23	2.23	2.96	2.96	2.96	2.96	2.23

## General Data

**Table 3 - CXAX 015-035 General Data (continued)**

		CXAX 015 SE-SN	CXAX 017 SE-SN	CXAX 020 SE-SN	CXAX 023 SE-SN	CXAX 026 SE-SN	CXAX 030 SE-SN	CXAX 035 SE-SN
<b>Condenser Fan</b>								
Quantity	#	1	1	2	2	2	2	2
Diameter	(mm)	800						
Fan / motor Type		Propeller axial fan						
<b>Digit 12=1 and Digit 15=A</b>								
Fan / motor Type		Fixed speed AC motor						
Airflow per fan	m <sup>3</sup> /h	13788	13828	12362	12362	12370	12375	14687
Max Power Input	Kw	0,89	0,89	0,89 + 0,89	0,89 + 0,89	0,89 + 0,89	0,89 + 0,89	0,89 / 0,89 + 0
Max Amps	A	2,22	2,22	2,22 + 2,22	2,22 + 2,22	2,22 + 2,22	2,22 + 2,22	2,22 / 2,22 + 0
Motor RPM	(rpm)	686	686	686	686	686	686	686
<b>Digit 12=1 and Digit 15=C</b>								
Fan / motor Type		Fixed speed AC motor / Variable speed						
Airflow per fan	m <sup>3</sup> /h	13788	13828	12362	12362	12370	12375	14687
Max Power Input	Kw	1,95	1,95	1,95 + 0,89	1,95 + 0,89	1,95 + 0,89	1,95 + 0,89	1,95 / 1,95 + 0
Max Amps	A	3	3	3 + 2,22	3 + 2,22	3 + 2,22	3 + 2,22	3 / 3 + 0
Motor RPM	(rpm)	686	686	686	686	686	686	686
Airflow per Fan	(m <sup>3</sup> /h)	13788	13828	12362	12362	12370	12375	14687
Power per Motor	(kW)	686	686	686	686	686	686	686
<b>Partial Heat recovery (PHR) option</b>								
Heat-Exchanger Type		Stainless steel Copper Brazed plate Heat exchanger						
Heat-Exchanger Model		B3-014-14-4.5M	B3-014-14-4.5M	B3-014-14-4.5M	B3-014-14-4.5M	B3-027-14-4.5L	B3-027-14-4.5L	2x B3-014-14-4.5M
Water connection size (Thread connection)	(in) - (mm)	G 1"1/4 (31.75 mm)	G 1"1/4 (31.75 mm)	G 1"1/4 (31.75 mm)	G 1"1/4 (31.75 mm)	G 1"1/4 (31.75 mm)	G 1"1/4 (31.75 mm)	G 1"1/4 (31.75 mm)
Water content volume	(l)	0.14	0.14	0.14	0.14	0.35	0.35	2x 0.14
<b>Dimensions (7)</b>								
Unit Length	(mm)	2346	2346	2346	2346	2346	2346	2327
Unit Width	(mm)	1285	1285	1285	1285	1285	1285	2250
Std Unit Height	(mm)	1524	1524	1524	1524	1524	1724	1524
LN or External SP unit - (Additional height configuration)	(mm)	+223	+224	+225	+226	+227	+228	+232
Water Buffer tank option - (Additional height configuration)	(mm)	+330	+330	+330	+330	+330	+330	+330
<b>Weights</b>								
Shipping Weight (3)	(kg)	558	564	616	644	649	684	1000
Operating Weight (3)	(kg)	539	545	596	624	630	665	974
<b>Option Additional shipping weight</b>								
Single pump - Standard head pressure	(kg)	46	46	46	49	49	49	45
Single pump - High head pressure	(kg)	51	51	51	51	51	51	49
Twin pump - Standard head pressure	(kg)	70	70	70	75	75	75	75
Twin pump - High head pressure	(kg)	82	82	82	82	82	82	84
Pump VFD option	(kg)	0						
<b>Partial heat recovery option</b>	(kg)	1.48	1.48	1.48	1.48	3.82	3.82	2x 1.48
Water Buffer tank option	(kg)	319	319	319	319	319	319	425
<b>System data</b>								
Nb of refrigerant circuit	#	1	1	1	1	1	1	2
Minimum cooling load % (6)	%	50	43	50	43	50	50	22
<b>Standard/Partial Heat Recovery Unit unit</b>								
R410A refrigerant charge Circuit1 / Circuit 2	(kg)	12.1	12.2	12.6	15.5	15.3	15.0	12.5
R454B refrigerant charge Circuit1 / Circuit 2	(kg)	10.0	10.0	10.5	12.5	12.5	12.0	10
Oil charge Circuit1 / Circuit 2 R410A & R454B	(l)	6.0	6.3	6.6	6.6	6.6	7.2	6.3
POE Oil type (6)		OIL058E / OIL057E						

- (1) Indicative performance at Evaporator water temperature : 12°C / 7°C - Condenser air temperature 35°C - for detailed performances, on a given unit, consult Order Write Up.
- (2) under 400V/3/50Hz.
- (3) Rated Condition without Pump Package.
- (4) Electrical & system data are indicative and subject to change without notice. Please refer to unit nameplate data.
- (5) If the power line of the unit is protected by fuses gG of the same size as the disconnect switch.
- (6) OIL058E or OIL057E are European reference for POE oil and can be mixed in any proportion with OIL00078 or OIL 00080 (same oil with US reference on compressor nameplate).
- (7) For dimensions details, dimensions of hydraulic connections, electrical connections, point load and specific features for heat recovery see submittals and diagrams which are supplied with every order.



## General Data

**Table 4 - CXAX 036-060 General Data**

		CXAX 036 SE-SN	CXAX 039 SE-SN	CXAX 040 SE-SN	CXAX 045 SE-SN	CXAX 046 SE-SN	CXAX 052 SE-SN	CXAX 060 SE-SN
Net cooling capacity R410a (1)	(kW)	95.9	109.9	114.8	119.2	127.9	143.7	155.3
Total Power input in cooling R410a (1)	(kW)	32.6	36.9	37.4	42.1	43.4	49.7	56.7
Net cooling capacity R454B (1)	(kW)	92.8	105.2	109.3	116.2	123.3	136.2	154.5
Total Power input in cooling R454B (1)	(kW)	29.7	34.0	37.2	37.9	42.1	45.6	51.7
<b>Unit electrical data (2) (3) (4)</b>								
Short Circuit Unit Capacity (9)	(kA)	15	15	15	15	15	15	15
Power Cable Cross Section (max)	mm <sup>2</sup>	150	150	150	150	150	150	150
Disconnect switch size	(A)	250	250	250	250	250	250	250
<b>Digit 12=1 and Digit 15=A</b>								
Maximum Power input	(kW)	43.0	49.0	51.6	55.5	59.0	66.5	74.0
Unit rated amps	(A)	73.8	81.0	90.4	95.8	100.6	110.8	127.6
Unit start up amps (w/o soft starter - Digit 26=A) (4)	(A)	197.9	213.7	212.2	221.3	233.3	243.5	253.1
Unit start up amps (with soft starter - Digit 26=B) (4)		139.1	150.5	155.4	159.3	170.1	180.3	191.1
Power factor		0.854	0.886	0.836	0.847	0.861	0.880	0.847
<b>Digit 12=1 and Digit 15=C</b>								
Maximum Power input	(kW)	44.1	50.0	53.7	56.6	61.2	68.6	76.1
Unit rated amps	(A)	74.6	81.8	91.9	96.6	102.1	112.3	129.1
Unit start up amps (w/o soft starter - Digit 26=A) (4)	(A)	198.7	214.5	213.7	222.1	234.8	245.0	254.6
Unit start up amps (with soft starter - Digit 26=B) (4)		139.9	151.3	156.9	160.1	171.6	181.8	192.6
Power factor		0.864	0.894	0.854	0.855	0.875	0.892	0.859
<b>Compressor</b>								
Compressor Number per Circuit	#	3	3	2	3	2	2	2
Type		Scroll	Scroll	Scroll	Scroll	Scroll	Scroll	Scroll
Model Circuit1 / Circuit 2		12+12+12	13+13+13	10+10 / 10+10	15+15+15	10+13 /10+13	13+13 / 13+13	15+15 / 15+15
Max Compr Power input Circuit 1/Circuit 2	kW	13.7 + 13.7 + 13.7	15.7 + 15.7 + 15.7	12 + 12 / 12 + 12	17.6 + 17.6 + 17.6	12 + 15.7 / 12 + 15.7	15.7 + 15.7 / 15.7 + 15.7	17.6 + 17.6 / 17.6 + 17.6
Rated Amps Circuit1 / Circuit 2 (4)	(A)	22.9 + 22.9 + 22.9	25.3 + 25.3 + 25.3	20.2 + 20.2 / 20.2 + 20.2	29.5 + 29.5 + 29.5	20.2 + 25.3 / 20.2 + 25.3	25.3 + 25.3 / 25.3 + 25.3	29.5 + 29.5 / 29.5 + 29.5
Locked Rotor Amps Circuit1 / Circuit 2 (4)	(A)	147 + 147 + 147	158 + 158 + 158	142 + 142 / 142 + 142	155 + 155 + 155	142 + 158 / 142 + 158	158 + 158 / 158 + 158	155 + 155 / 155 + 155
Motor RPM	(rpm)	2900	2900	2900	2900	2900	2900	2900
Oil sump heater Circuit1 / Circuit 2	(W)	0.25 / 0	0.25 / 0	0.17 / 0.17	0.25 / 0	0.17 / 0.17	0.17 / 0.17	0.17 / 0.17
<b>Evaporator</b>								
Quantity	#	1	1	1	1	1	1	1
Type		Stainless steel Copper Brazed plate Heat exchanger						
Evaporator model		P120Tx104	P120Tx104	DP300x82	P120Tx104	DP300x82	DP300x114	DP300x114
Evaporator Water Content volume	(l)	12.5	12.5	8.5	12.5	8.5	11.8	11.8
Nominal water connection size (Grooved coupling) - Without HYM	(in) - (mm)	2" - 60.3	2" - 60.3	3" OD - 76.1	2" - 60.3	3" OD - 76.1	3" OD - 76.1	3" OD - 76.1
Nominal water connection size (Grooved coupling) - With HYM	(in) - (mm)	3" OD - 76.1	3" OD - 76.1	3" OD - 76.1	3" OD - 76.1	3" OD - 76.1	3" OD - 76.1	3" OD - 76.1
<b>Hydraulic Module Components</b>								
<b>Single pump - Standard head pressure option</b>								
Max available Head Pressure	(kPa)	103	131	133	104	114	113	178
Motor Power	(kW)	1.50	2.30	2.30	2.30	2.30	2.30	2.30
Rated Amps	(A)	3.50	5.03	5.03	5.03	5.03	5.03	5.03
<b>Single pump - High head pressure option</b>								
Max available Head Pressure	(kPa)	190	176	179	151	162	162	138
Motor Power	(kW)	3.00	3.00	3.00	3.00	3.00	3.00	3.00
Rated Amps	(A)	6.23	6.23	6.23	6.23	6.23	6.23	6.23
<b>Twin pump - Standard head pressure option</b>								
Max available Head Pressure	(kPa)	103	131	133	104	114	113	178
Motor Power	(kW)	1.50	2.30	2.30	2.30	2.30	2.30	2.30
Rated Amps	(A)	3.50	5.03	5.03	5.03	5.03	5.03	5.03
<b>Twin pump - High head pressure option</b>								
Max available Head Pressure	(kPa)	190	176	179	151	162	162	138
Motor Power	(kW)	3.00	3.00	3.00	3.00	3.00	3.00	3.00
Rated Amps	(A)	6.23	6.23	6.23	6.23	6.23	6.23	6.23
Expansion Tank Volume	(l)	35	35	35	35	35	35	35
Max User water loop Volume for factory mounted expansion tank (1)	(l)	2000	2000	2000	2000	2000	2000	2000
Optionnal water Buffer tank volume	(l)	444	444	444	444	444	444	444
Antifreeze Heater without pump package	(W)	180	180	120	180	120	180	180
Antifreeze Heater with pump package	(W)	340	340	280	340	280	340	340
<b>Condenser</b>								
Type		Full aluminum Micro channel heat exchanger						
Quantity of coil	#	2	2	2	2	2	2	2
Face area per circuit	(m <sup>2</sup> )	4.46	5.93	2.96	5.93	2.96	2.96	2.96



## General Data

Table 4 - CXAX 036-060 General Data (continued)

		CXAX 036 SE-SN	CXAX 039 SE-SN	CXAX 040 SE-SN	CXAX 045 SE-SN	CXAX 046 SE-SN	CXAX 052 SE-SN	CXAX 060 SE-SN
<b>Condenser Fan</b>								
Quantity	#	1	2	4	3	4	4	4
Diameter	(mm)	800						
Fan / motor Type		Propeller axial fan						
<b>Digit 12=1 and Digit 15=A</b>								
Fan / motor Type		Fixed speed AC motor						
Airflow per fan	m <sup>3</sup> /h	13788	14690	12358	13676	12363	12592	12374
Max Power Input	Kw	0.89	0.89 + 0.89	0.89 + 0.89 / 0.89 + 0.89	0.89 + 0.89 / 0.89 + 0.89	0.89 + 0.89 / 0.89 + 0.89	0.89 + 0.89 / 0.89 + 0.89	0.89 + 0.89 / 0.89 + 0.89
Max Amps	A	2.22	2.22 + 2.22	2.22 + 2.22 / 2.22 + 2.22	2.22 + 2.22 / 2.22 + 2.22	2.22 + 2.22 / 2.22 + 2.22	2.22 + 2.22 / 2.22 + 2.22	2.22 + 2.22 / 2.22 + 2.22
Motor RPM	(rpm)	686	686	686	686	686	686	686
<b>Digit 12=1 and Digit 15=C</b>								
Fan / motor Type		Fixed speed AC motor / Variable speed						
Airflow per fan	m <sup>3</sup> /h	13788	14690	12358	13676	12363	12592	12374
Max Power Input	Kw	1.95	1.95 + 0.89	1.95 + 0.89 / 1.95 + 0.89	1.95 + 0.89 / 1.95 + 0.89	1.95 + 0.89 / 1.95 + 0.89	1.95 + 0.89 / 1.95 + 0.89	1.95 + 0.89 / 1.95 + 0.89
Max Amps	A	3	3 + 2.22	3 + 2.22 / 3 + 2.22	3 + 2.22 / 3 + 2.22	3 + 2.22 / 3 + 2.22	3 + 2.22 / 3 + 2.22	3 + 2.22 / 3 + 2.22
Motor RPM	(rpm)	686	686	686	686	686	686	686
Airflow per Fan	(m <sup>3</sup> /h)	13788	14690	12358	13676	12363	12592	12374
Power per Motor	(kW)	686	686	686	686	686	686	686
<b>Partial Heat recovery (PHR) option</b>								
Heat-Exchanger Type		Stainless steel Copper Brazed plate Heat exchanger						
Heat-Exchanger Model		B3-014-14-4.5M	B3-027-20-4.5L	2x B3-014-14-4.5M	B3-027-20-4.5L	2x B3-014-14-4.5M	B3-027-14-4.5L	2x B3-027-14-4.5L
Water connection size (Thread connection)	(in) - (mm)	G 1"1/4 (31.75 mm)	G 1"1/4 (31.75 mm)	G 1"1/4 (31.75 mm)	G 1"1/4 (31.75 mm)	G 1"1/4 (31.75 mm)	G 1"1/4 (31.75 mm)	G 1"1/4 (31.75 mm)
Water content volume	(l)	0.14	0.5	2x 0.14	0.5	2x 0.14	2x 0.35	2x 0.35
<b>Dimensions (7)</b>								
Unit Length	(mm)	2346	2327	2327	2327	2327	2327	2327
Unit Width	(mm)	1285	2250	2250	2250	2250	2250	2250
Std Unit Height	(mm)	1524	1524	1524	1524	1524	1524	1724
LN or External SP unit - (Additional height configuration)	(mm)	+223	+230	+233	+231	+234	+235	+236
Water Buffer tank option - (Additional height configuration)	(mm)	+330	+330	+330	+330	+330	+330	+330
<b>Weights</b>								
Shipping Weight (3)	(kg)	558	954	1098	972	1098	1120	1190
Operating Weight (3)	(kg)	539	925	1072	942	1072	1093	1163
<b>Option Additional shipping weight</b>								
Single pump - Standard head pressure	(kg)	46	47	47	47	47	47	47
Single pump - High head pressure	(kg)	51	49	49	49	49	49	49
Twin pump - Standard head pressure	(kg)	70	75	75	75	75	75	75
Twin pump - High head pressure	(kg)	82	86	84	86	84	84	84
Pump VFD option	(kg)	0						0
<b>Partial heat recovery option</b>	(kg)	1.48	4.6	2x 1.48	4.6	2x 1.48	2x 3.82	2x 3.82
Water Buffer tank option	(kg)	319	425	425	425	425	425	425
<b>System data</b>								
Nb of refrigerant circuit	#	1	1	2	1	2	2	2
Minimum cooling load % (6)	%	50	33	25	33	22	25	25
<b>Standard/Partial Heat Recovery Unit unit</b>								
R410A refrigerant charge Circuit1 / Circuit 2	(kg)	26.6	26.7	13	26.6	13	13	14
R454B refrigerant charge Circuit1 / Circuit 2	(kg)	21.5	21.5	10.5	21.5	10.5	10.5	11.5
Oil charge Circuit1 / Circuit 2 R410A & R454B	(l)	6.0	10.5	6.6	11.5	6.6	6.6	7.2
POE Oil type (6)		OIL058E / OIL057E						

- (1) Indicative performance at Evaporator water temperature : 12°C / 7°C - Condenser air temperature 35°C - for detailed performances, on a given unit, consult Order Write Up.
- (2) under 400V/3/50Hz.
- (3) Rated Condition without Pump Package.
- (4) Electrical & system data are indicative and subject to change without notice. Please refer to unit nameplate data.
- (5) If the power line of the unit is protected by fuses gG of the same size as the disconnect switch.
- (6) OIL058E or OIL057E are European reference for POE oil and can be mixed in any proportion with OIL00078 or OIL 00080 (same oil with US reference on compressor nameplate).
- (7) For dimensions details, dimensions of hydraulic connections, electrical connections, point load and specific features for heat recovery see submittals and diagrams which are supplied with every order.

# Installation – Mechanical

## Location Requirements

### Sound Considerations

The most effective form of acoustical isolation is to locate the unit away from any sound sensitive area. Structurally transmitted sound can be reduced by elastomeric vibration eliminators. Spring isolators are not recommended. Consult an acoustical engineer in critical sound applications.

### Foundation

**Figure 2 - Installation example**

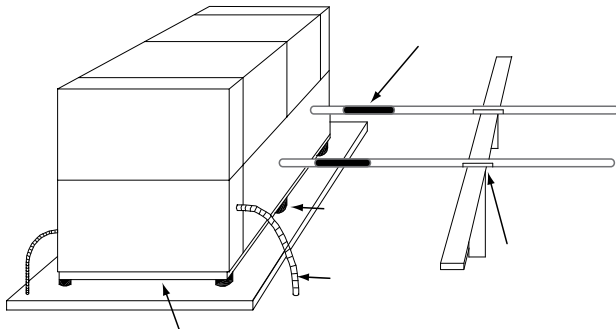

For maximum isolation effect, water lines and electrical conduit should also be isolated. Wall sleeves and rubber isolated piping hangers can be used to reduce the sound transmitted through water piping. To reduce the sound transmitted through electrical conduit, use flexible electrical conduit.

EU and Local codes on sound emissions should always be considered. Since the environment in which a sound source is located affects sound pressure, unit placement must be carefully evaluated. Consult an acoustical engineer for critical applications.

Provide rigid, non-warping mounting pads or a concrete foundation of sufficient strength and mass to support the applicable operating weight (i.e. including completed piping, and full operating charges of refrigerant, oil and water). Refer to the chapter on Unit Dimensions/Weights for unit operating weights. Once in place, the unit must be level with 3 mm over its length and width. Trane is not responsible for equipment problems resulting from an improperly designed or constructed foundation.

### Clearances

Provide enough space around the unit to allow the installation and maintenance personnel unrestricted access to all service points. Refer to submittal drawings for the unit dimensions, to provide sufficient clearance for the opening of control panel doors and unit service. Refer to the chapter on Unit Dimensions/Weights for minimum clearances. In all cases, local codes which require additional clearances will take precedence over these recommendations.

**If the installation includes several units or if units are close to walls, contact your local Trane Sales Office for additional requirements.**

Winter operation: CXAX coil will not be obstructed at any time by snow or ice.

Specific attention should be paid to avoid accumulation of ice and snow at the bottom of the coil.

### Rigging

Refer to weights tables for typical unit lifting weights. Refer to the rigging label attached to the unit for further details.

### Lifting Procedure

Refer to the lifting label affixed to the unit. Lifting beam crossbars **MUST** be positioned so lifting cables do not contact the sides of the unit. Adjust as necessary for even level lift.

- 1- Use the four rigging points which are built into the unit.
- 2- Slings and a spreader bar are to be provided by the rigger.
- 3 - The minimum lifting capacity of each sling as well as the spreader bar must be equal or higher than the tabulated unit shipping weight.
- 4- Caution: this unit must be lifted and handled with care. Avoid shocks while handling.

## Unit isolation and Leveling

### Mounting

Construct an isolated concrete pad for the unit or provide concrete footings at each of the four unit mounting points. Mount the unit directly to the concrete pads or footings. Level the unit using the base rail as a reference. The unit must be level within 5 mm over the entire length. Use shims as necessary to level the unit.

### Isolation Pads installation (Optional)

Install the optional neoprene pads at each mounting location. Refer to unit submittals for further details on location. Consult a vibration engineer for critical applications.

## Evaporator piping

Evaporator water connections are grooved. Thoroughly flush all water piping to the CGAX or CXAX units before making the final piping connections to the unit. Components and layout will vary slightly, depending on the location of connections and the water source.

### CAUTION Equipment Damage!

If using an acidic commercial flushing solution, construct a temporary bypass around the unit to prevent damage to internal components of the evaporator.

### CAUTION Proper Water Treatment!

The use of untreated or improperly treated water in a chiller may result in scaling, erosion, corrosion, algae or slime. It is recommended that the services of a qualified water treatment specialist be engaged to determine what water treatment, if any, is required. Trane assumes no responsibility for equipment failures which result from untreated or improperly treated water, or saline or brackish water.

## Installation – Mechanical

### Drainage

Locate the unit near a large capacity drain for water vessel draindown during shutdown or repair. Water piping is provided with drain connections. Refer to "Water Piping." All local and national codes apply.

### Piping

A vent is provided on the top of the evaporator at the return end. Be sure to provide additional vents at high points in the piping to bleed air from the chilled water system. Install necessary pressure gauges to monitor the entering and leaving chilled water pressures.

Provide shutoff valves in lines to the gauges to isolate them from the system when they are not in use. Use rubber vibration eliminators to prevent vibration transmission through the water lines. If desired, install thermometers in the lines to monitor entering and leaving water temperatures. Install a balancing valve in the leaving water line to control water flow balance. Install shutoff valves on both the entering and leaving water lines so that the evaporator can be isolated for service. Make sure the water circuit includes all devices and controls used to provide proper water system operation and unit operating safety. Refer to the appropriate sections in the unit manual (Addendum\_PROD-SVX01) for Installation, appropriate procedures, component specifications and safety instructions.

**Figure 3 - Unit typical water circuit**

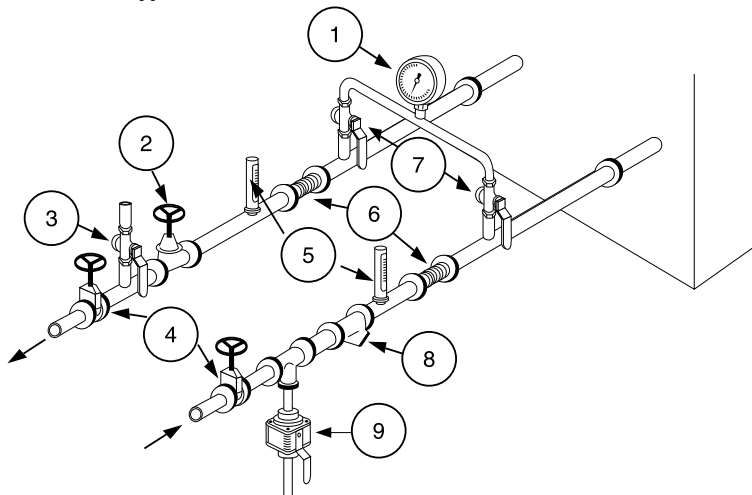

- 1 = Pressure gauges: show entering and leaving water pressure
- 2 = Balancing valve: adjusts water flow.
- 3 = Air purge allows to remove the air from the water circuit during fill up.
- 4 = Stop valves: isolate chillers and water circulating pump during maintenance operations.
- 5 = Thermometers: indicate chilled water entering and leaving temperatures.
- 6 = Expansion compensators: avoid mechanical stress between chiller and piping installation.
- 7 = Stop valve located on the outlet connection: used to measure the water pressure inlet or outlet of evaporator.
- 8 = Strainer: avoid to get heat exchangers dirty. All installation must be equipped with efficient strainer in order that only clean water enters into exchanger. If there is no strainer, reserve will be formulated by the Trane technician at the start-up of the unit. The trainer used must be able to stop all particles with a diameter greater than 1 mm.
- 9 = Draining: used as the draining the plate heat exchanger.
- 10 = Do not start the unit with low water volume or not enough pressurized circuit.

**Note:** A pressure switch device to detect lack of water is not included in the pump package. Installation of this type of device is highly recommended to avoid sealing damage due to operation of pump without enough water.

### Minimal installation water content

The water volume is an important parameter because it allows as table chilled water temperature and avoids short cycle operation of the compressors.

#### Parameters which influence the water temperature stability

- Water loop volume
- Load fluctuation
- Number of capacity steps
- Compressors rotation
- Dead band (adjusted on chiller controller)
- Minimum time between 2 starts of a compressor

#### Minimum water volume for a comfort application

For comfort application we can allow water temperature fluctuation at part load. The parameter to take into account is the minimum operating time of the compressor. In order to avoid lubrication problem on a scroll compressor it must run at least 2 minutes (120 seconds) before it stops.

## Installation – Mechanical

**The minimum volume can be determined by using the following formula:**

Volume = Cooling capacity x Time x highest capacity step (%) / Specific heat / Dead band

Minimum operating time = 120 seconds

Specific heat = 4.18 kJ / kg

Average Dead band = 3°C (or 2°C)

Note: To estimate the biggest step, it is usually more reliable to make a selection at lower ambient temperature where efficiency is higher and compressors steps bigger. It is also essential to take into account the brine specific heat, in case of the use of glycol.

Process applications will need more water volume to minimize the water temperature fluctuation at part load.

**Table 3 - Minimum water volumes for comfort applications**

Unit Size	Capacity (KW)	Biggest Step (%)	Minimum Water Volume (l) Dead band = 2 °C	Minimum Water Volume (l) Dead band = 3 °C
15	42	50	301	201
17	48	57	393	262
20	58	50	416	278
23	65	56	522	348
26	74	50	531	354
30	82	50	589	392
36	94	33	445	297
39	107	33	507	338
45	123	33	583	388
35	96	33	455	303
40	114	25	409	273
46	126	28	506	338
52	143	25	513	342
60	160	25	574	383

### Expansion tank (option)

The factory-installed expansion tank initial pressure should be adjusted about 0.2 bar lower than the static pressure of the circuit at the pump inlet. The expansion tank volume has been selected for typical loop volume. It is recommended to check the expansion tank volume with the installation information.

The following data is required:

- C = Water capacity of the circuit
- e = Expansion coefficient (difference between max and min water temperature, in operation or not)
- Pi = Initial pressure of the expansion tank
- Pf = Final pressure: Max is given by the pressure relief valve

**Minimum Volume of expansion tank = (C x e)/(1-Pi/Pf)**

Expansion coefficient of water at various temperatures

°C	e
0	0.00013
10	0.00027
20	0.00177
30	0.00435
40	0.00782
50	0.01210

## Installation – Mechanical

### Freeze Protection

If the unit is exposed to ambient temperatures below 0°C, the chilled water system must be protected from freezing following one of the options shown below:

1. Heaters

a. Heaters can be factory-installed (option) on the evaporator and water piping and will protect it from freezing in ambient temperatures down to -18°C.

AND

b. Install, outside the unit, heat tape on all water piping, pumps, and other components that may be damaged if exposed to freezing temperatures. Heat tape must be designed for low ambient temperature applications. Heat tape selection should be based on the lowest expected ambient temperature.

OR

2. Freeze inhibitor

a. Add a freeze inhibitor fluid to the chilled water system. The solution must be strong enough to provide protection against ice formation at the lowest anticipated ambient temperature.

**Note: Use of a freeze inhibitor fluid reduces the cooling capacity of the unit and must be considered in the design of the system specifications.**

3. Water pump

a. Chiller controller can start the pump to prevent freezing. This function needs to be validated, pump has to be controlled by the unit and water circuit valves need to stay open at all times. This protection will be efficient to protect the unit, if the water loop is reduced. The installation of a bypass is advised.

If ambient temperatures below -18°C, the water circuit must be protected against freezing.

Add a freeze inhibitor fluid and activate the heat tape on the unit; do not shut the unit down.

It is not recommended to drain the water circuit for the following reasons:

1. The water circuit will rust and its lifetime could be reduced.
2. Water will remain in the bottom of the plate heat exchangers and freeze damage could occur.

**Note: If water pump control is enabled form the chiller controller, it will request start of customer pump during ambient air temperatures below freezing.**

**CAUTION!** When using freeze inhibitor, never fill the system with pure glycol. Always fill the system with diluted solution. Maximum concentration of glycol is 40%. Higher glycol concentration will damage pump seal.

**Note: Never fill high Glycol concentration at the pump suction as there is a high risk to damage pump seal.**

In case of winter water drainage for freeze protection, it is compulsory to disconnect the evaporators heaters to protect them from burning due to overheat.

**Note:** Water pump control and heater combination will protect the evaporator down to any ambient temperature provided power is available to the pump and the controller. This option will NOT protect the evaporator in the event of power failure to the chiller unless backup power is supplied to the necessary components.

**The warranty will be void, in case of freezing due to the lack of use of either of these protections.**

### Low refrigeration temperature setpoint and antifreeze setpoint on chiller controller

**CAUTION!** The chiller is provided with standard factory settings. It can be necessary to modify the Low Pressure saturation Temperature and the Antifreeze Setpoint on the unit control. Based on the following examples, it is necessary to modify on the chiller controller the following settings:

- The LP saturation temperature (LRTC)
- The antifreeze setpoint (LWTC)

Examples:

For:

- 7°C, the LP setting must be -4°C where the antifreeze setting shall be 2°C
- 2°C, the LP setting must be -9°C where the antifreeze setting shall be -4°C
- -12°C, the LP setting must be -23°C where the antifreeze setting shall be -17°C

### Freeze protection with glycol

It is mandatory to use a freeze inhibitor for leaving water setpoint less or equal to 5°C. On the glycol recommended concentration figure, you must select concentration on or above the curve. For example, for -4°C brine temperature, a concentration of 25% ethylene glycol is not sufficient. The concentration must be 28% ethylene glycol or 33% propylene glycol.

### Using glycol with hydraulic module

If the glycol brine percentage is not at the recommended percentage (greyed area), corrosion inhibitor present in the glycol may not be efficient enough. For instance, a glycol concentration of 15% will provide freeze protection to the unit down to -5°C, but it might generate additional corrosion.

## Installation – Mechanical

**Figure 4 - LP setting vs. Leaving Water Temperature setpoint**

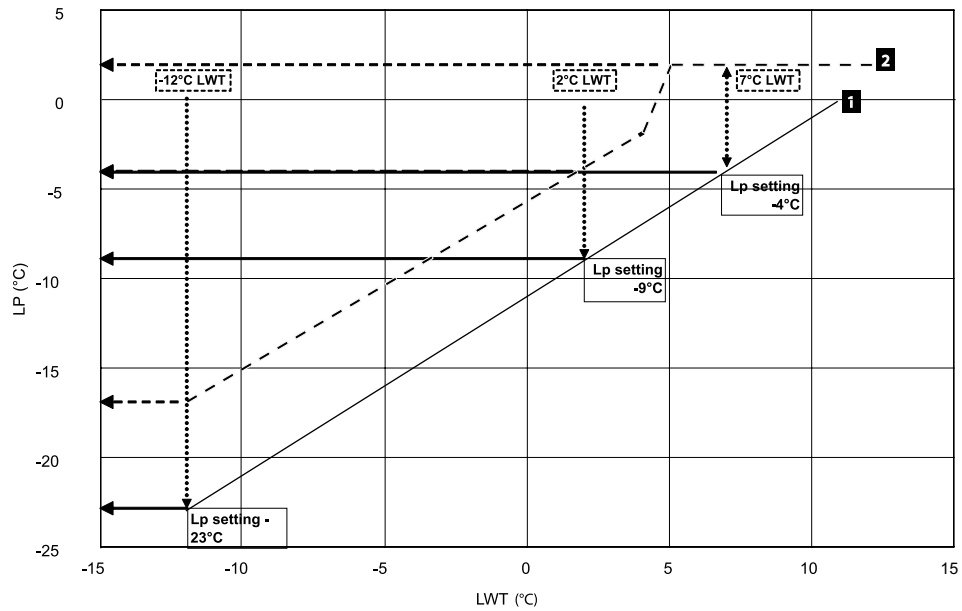

**Figure 5 - Glycol percentage recommendation curve**

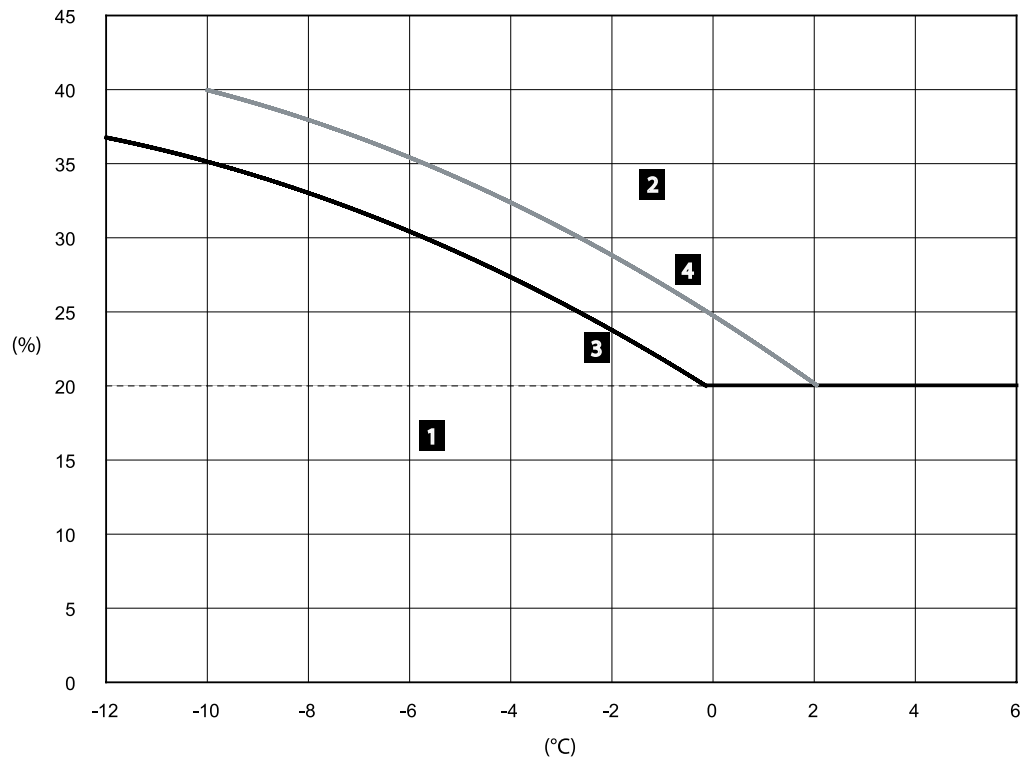

- 1 = Critical risks of freezing
- 2 = Efficient freeze protection
- 3 = Ethylene glycol
- 4 = Propylene glycol
- % = Glycol percentage (mass concentration)
- °C = Glycol or water temperature

# Hydraulic Data

**CGAX Unit without pump package  
(Pressure drop)**

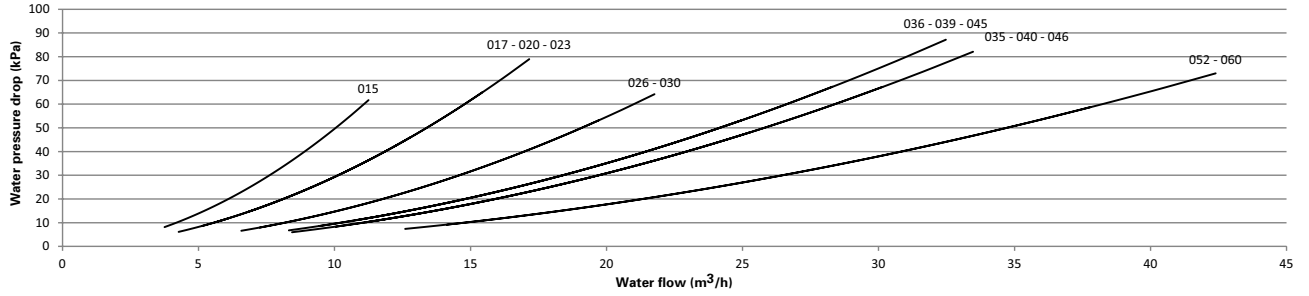

**CGAX Single/Twin pump - Standard head pressure  
(Avail. pressure)**

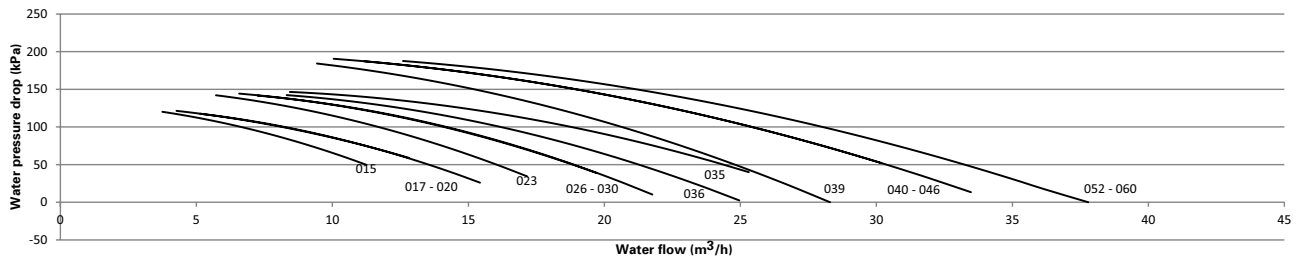

**CGAX Single/Twin pump - High head pressure  
(Avail. pressure)**

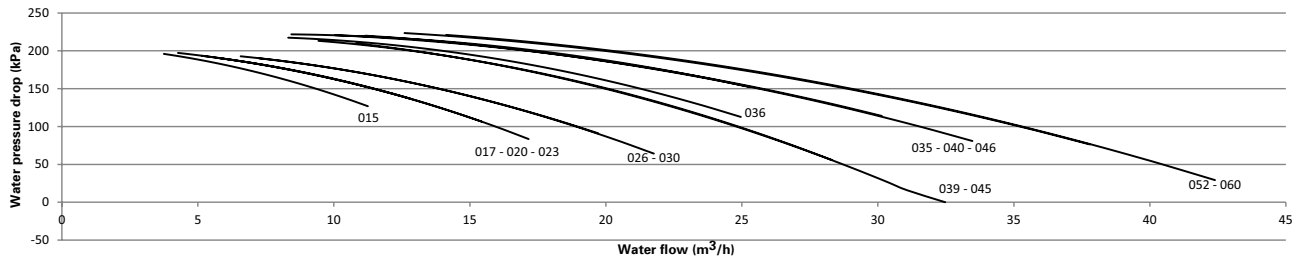

Note: Extremity of the curves represents minimum and maximum water flow.



## Hydraulic Data

**CXAX Unit without pump package  
(Pressure drop)**

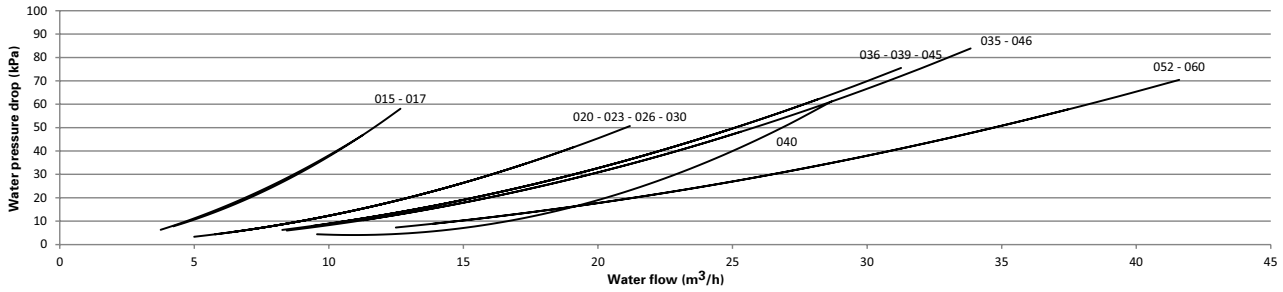

**CXAX Single/Twin pump - Standard head pressure  
(Avail. pressure)**

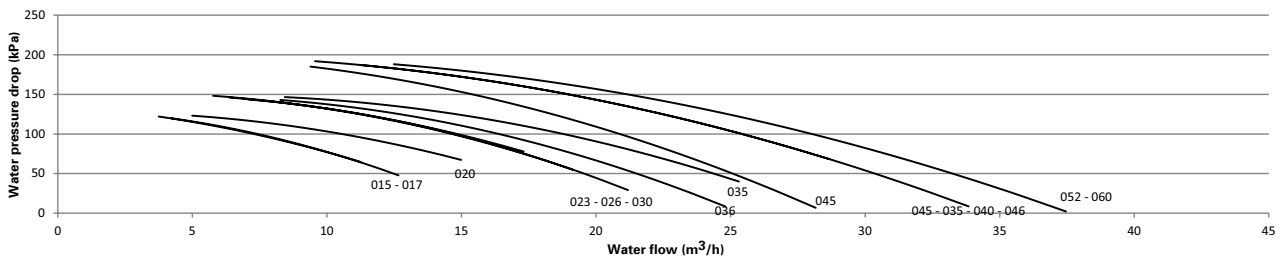

**CXAX Single/Twin pump - High head pressure  
(Avail. pressure)**

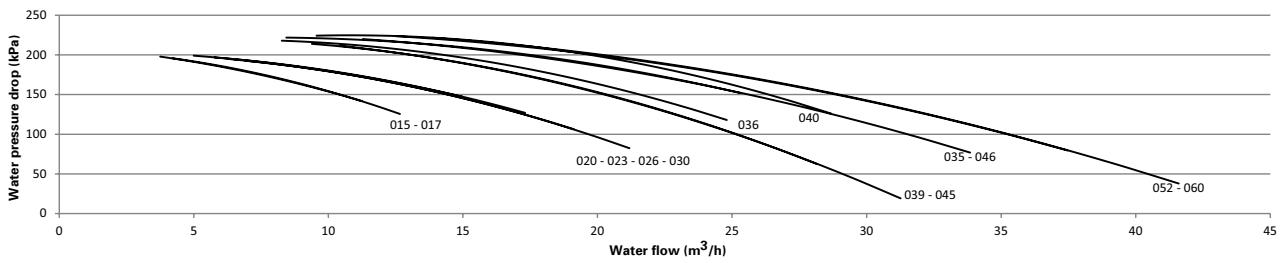

Note: Extremity of the curves represents minimum and maximum water flow.

# Operating Map

## CGAX

Minimum Starting Operating Ambient

- Std Ambient unit = 5°C

- Low Ambient unit = -18°C

Maximum Ambient = 46°C

Evaporator Outlet Temperature

- Comfort application [5°C; 20°C]

- Process application [-12°C; 5°C]

**Figure 6 - Operating map- Cooling-only Model CGAX**

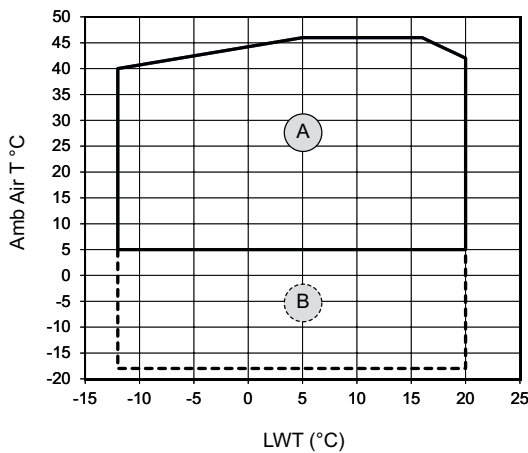

LWT = Leaving Water Temperature

Amb Air T = Ambient air Temperature

A = Standard operating map

B = Low ambient operating map (Variable air flow control)

Minimum start-up/operation ambient based on a 2.22 m/s (5mph) wind across the condenser

## CXAX

Minimum Starting Operating Ambient

- Std Ambient unit

Cooling mode = 5°C

Heating mode = -15°C

- Low Ambient unit

Cooling mode = -10°C

Heating mode = -15°C

Maximum Ambient = 46°C

Evaporator outlet temperature

- Comfort Application [5°C; 20°C]

- Process Application [-10°C; 5°C]

**Figure 7 - Heat Pump Model CXAX operating map**

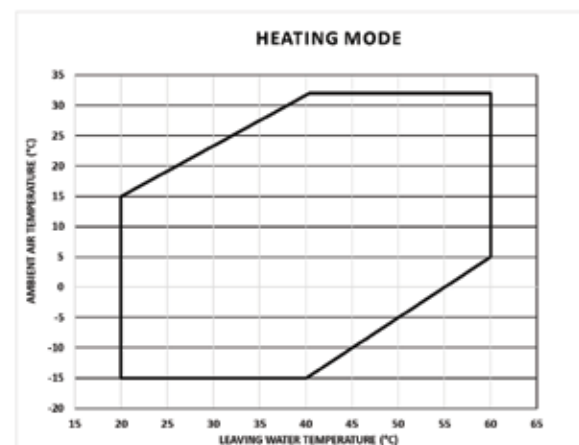
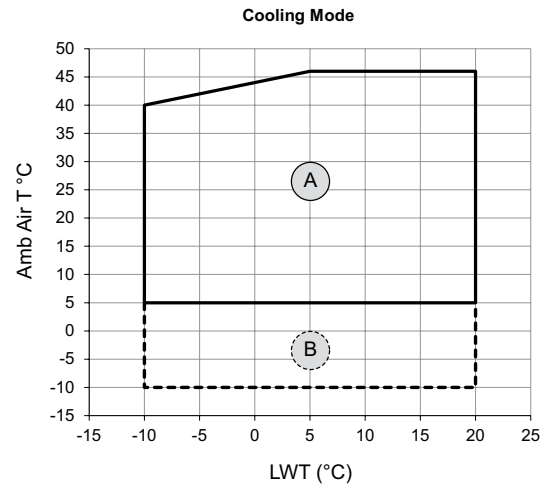

# Partial Heat Recovery

Heat recovery option is made with a plate heat exchanger in series with the air-cooled condenser. This heat exchanger benefits the discharge gas superheat as well as a part of the condensing gas heat to be transferred to hot water system.

All submittals, lifting diagrams, neoprene pads, positioning and wiring diagrams have been supplied with the chiller order.

## Water pressure - Cooling only CGAX Heat Exchanger

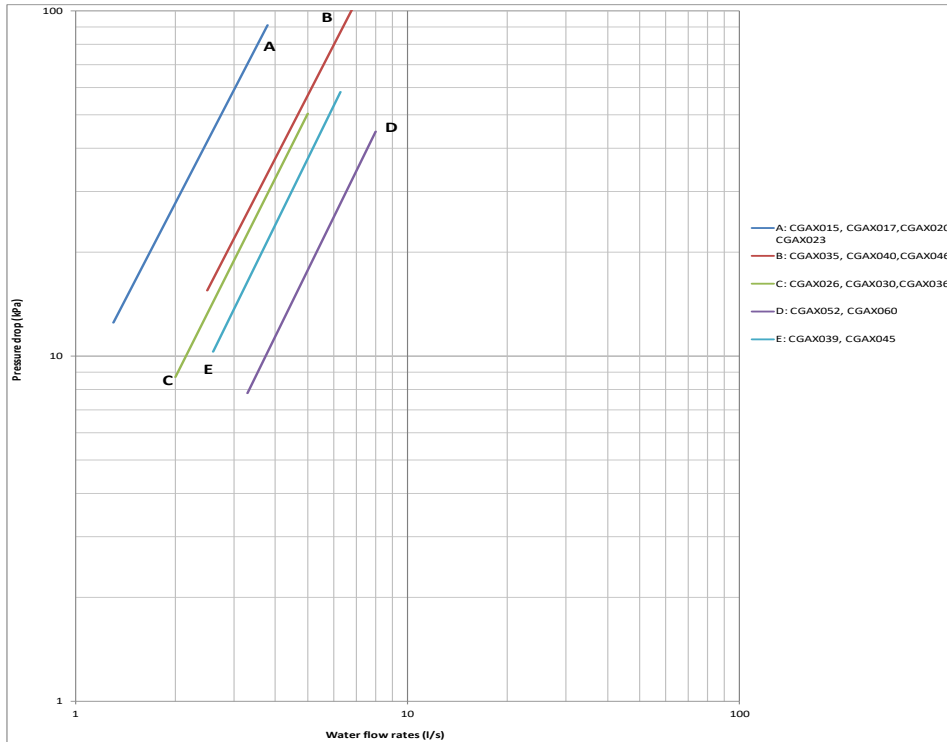

## Water pressure - Heat Recovery CXAX Heat Exchanger

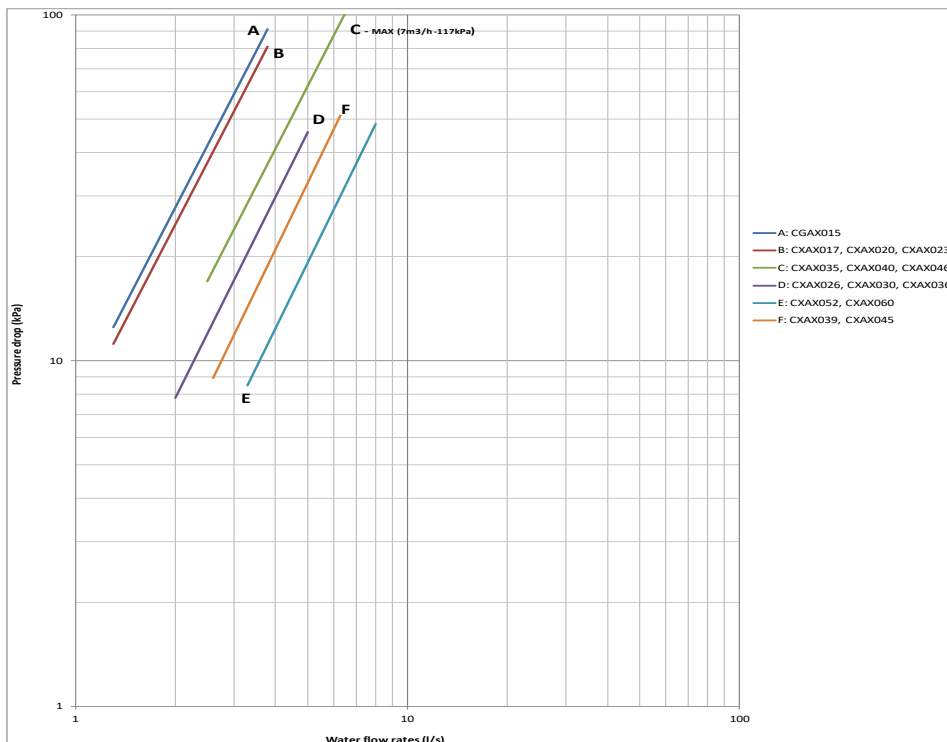



# Installation – Electrical

## General Recommendations

When reviewing this manual keep in mind:

- All field-installed wiring must be in accordance with local regulations and CE directives and guidelines. Be sure to satisfy proper equipment grounding requirements according CE
- The following standardized values - Maximum Amps - Short Circuit Amps - Starting Amps are displayed on unit nameplate.
- All field-installed wiring must be checked for proper terminations, and for possible shorts or grounds.

**Note:** *always refer to wiring diagrams shipped with chiller or unit submittal for specific electrical schematic and connection information.*

### **WARNING Hazardous Voltage!**

Disconnect all electric power, including remote disconnects before servicing. Follow proper lockout/tagout procedures to ensure the power cannot be inadvertently energized. Failure to disconnect power before servicing could result in death or serious injury.

**CAUTION!** Time before to work on the electrical panel of the unit with Low Ambient option: once the unit is off (confirmed by the extinction of the display), it is mandatory to wait five minutes before working on the electrical panel.

**CAUTION!** To avoid corrosion, overheating or general damage, at terminal connections, unit is designed for copper conductors only. In case of aluminum conductors an intermediate connection box must be added. In case of aluminum cable bi material connecting device is mandatory. Cable routing inside control panel should be made case by case by installer.

### **Important!**

Do not allow conduit to interfere with other components, structural members or equipment. Control voltage (230 V) wiring in conduit must be separate from conduit carrying low voltage (<30V) wiring. To prevent control malfunctions, do not run low voltage wiring (<30V) in conduit with conductors carrying more than 30 volts.

### **Soft starter recommended settings**

Acceleration time: 0.5 second speed Start-up torque: 50%

Deceleration time: 0 second

**CAUTION!** Inverters are equipped with integrated filters. They are not compatible with insulated neutral load earthing arrangements.

### **WARNING! High voltage!**

Any contact with electric components, even after the unit has been switched off, can cause serious injury or death. Wait at least 4 minutes after switching off the unit, until the current dissipates.

### **Grounding**

Note the fan speed inverter has a high leakage current. Be sure to ground the unit and take this into account when installing the differential protection device. Differential protection should be suited for industrial machinery with current leak which can be higher than 100 mA (several motors and frequency drives).

## Installer-Supplied Components

Customer wiring interface connections are shown in the electrical schematics and connection diagrams that are shipped with the unit. The installer must provide the following components if not ordered with the unit:

- Power supply wiring (in conduit) for all field-wired connections.
- All control (interconnecting) wiring (in conduit) for field supplied devices.
- Circuit breakers.

## Power Supply Wiring

### **WARNING Ground Wire!**

All field-installed wiring must be completed by qualified personnel. All field-installed wiring must comply with local codes and regulations. Failure to follow this instruction could result in death or serious injury.

All power supply wiring must be sized and selected accordingly by the project engineer in accordance with local codes and regulations.

### **WARNING Hazardous Voltage!**

Disconnect all electric power, including remote disconnects before servicing. Follow proper lockout/tagout procedures to ensure the power can not be inadvertently energized. Failure to disconnect power before servicing could result in death or serious injury.

All wiring must comply with local codes and regulations. The installing (or electrical) contractor must provide and install the system interconnecting wiring, as well as the power supply wiring. It must be properly sized and equipped with the appropriate fused disconnect switches. The type and installation location(s) of the fused disconnects must comply with all applicable codes. Knock-outs for wiring are located on the bottom right side of the control panel. The wiring is passed through these conduits and connected to the disconnect switch. To provide proper phasing of 3-phase input, make connections as shown in field wiring diagrams and as stated on the WARNING label in the starter panel. For additional information on proper phasing, refer to "Unit Voltage Phasing." Proper equipment ground must be provided to each ground connection in the panel (one for each customer supplied conductor per phase). High voltage field-provided connections are made through knockouts on the right side of the panel.

## Installation – Electrical

Figure 8 - Power Entrance

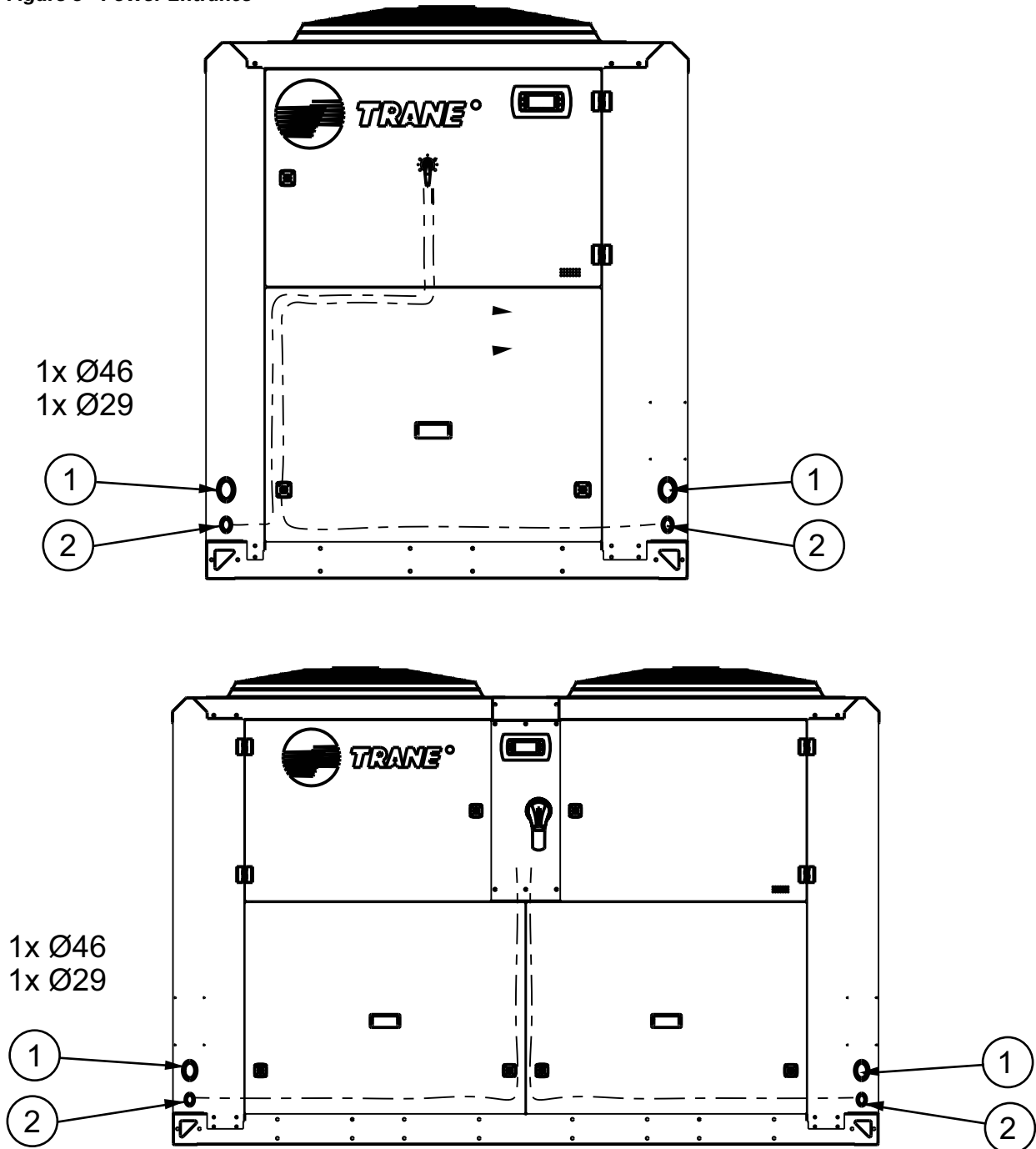

1 = Incoming power (left side or right side to best suit installation)

2 = Low voltage power (left side or right side to best suit installation)



## Electrical Data

For electrical data details, refer to General Data tables for each unit configuration and size.

- Maximum Power input (kW)
- Unit rated amps (Max compr Fan+Control)
- Unit start up amps (Starting Amps of the largest compr+RLA of 2nd compr+RLA of all fans+ control)
- Compressor Power factor
- Disconnect switch size (A)

Wiring diagrams are shipped with unit and can be found in the unit control panel.

Note : Rating is made for 400 V, 3 phases, 50 Hz power supply.

## Control Power Supply

**Note: it is highly recommendable to read this section within the wiring diagrams, where the different components mentioned here are referenced.**

### General

Unit is equipped with a control transformer (1T1), factory mounted, wired and tested, therefore it is not necessary to provide additional control power voltage to the unit. No other loads should be connected to the control power transformer. All units are factory-connected for appropriate labelled voltages.

## Interconnecting Wiring / Low Voltage Wiring

### **WARNING Ground Wire!**

All field-installed wiring must be completed by a qualified personnel, and must comply with local codes and regulations. Failure to follow those instructions could result on death or serious injury. The remote devices described on the sections ahead require low voltage wiring. All wiring to and from these remote input devices to the Control Panel must be made with shielded, twisted pair conductors. Be sure to ground the shielding only at the panel.

**Note : To prevent control malfunctions, do not run low voltage wiring (< 30V) in conduit with conductors carrying more than 30V.**

## Customer Options

### **Alarm and Status Relay Outputs (Programmable Relays)**

A programmable relay concept provides for enunciation of certain events or states of the chiller, selected from a list of likely needs, while only using physical outputs relays, as shown on the field diagram. Four electromechanical relays board are provided, as part of the customer input/output option.

The digital outputs must be properly protected against short circuits and overloads.

The minimum cross-section of the cables used for the digital outputs must be 1.5 mm<sup>2</sup>.

Relay characteristics

relay ratings :

at 120 VAC : 7.2 Amps resistive / 2.88 Amps pilot duty  
at 240 VAC: 5 Amps general purpose.

The list of events/states that can be assigned to the programmable relays can be found on the follow table. The relay will be energized when the event/state occurs:

## External Auto/Stop

If the unit requires external auto/stop function, the installer must provide leads from the remote contacts on unit main controller. Operation is described in document CNT-SVU006.

## Heat Pump Control and Heating / Cooling Selection

On Heat Pump version units (CXAX), change for Heating/ Cooling can be done remotely, from a remote contact. Operation is described in document CNT-SVU006.

## Auxiliary Setpoint

If the unit requires an external Auxiliary Leaving Water Temperature Setpoint, the installer must provide leads from the remote contacts on unit Auxiliary Setpoint binary Input terminal.

Chiller will operate normally, using the LWT Setpoint, established on the unit controller, whenever the contact will be closed, the unit will move to the Auxiliary LWT Setpoint.

## External Chilled Water Setpoint (ECWS/EHWS) Option

External analog signal can be used to change active chilled/hot water setpoint through either 0-10VDC or 4-20mA signals to set the external chilled/hot water setpoint (ECWS/EHWS). Operation is described in document CNT-SVU006.

## External Demand Limit Setpoint (EDLS) Option

External analog signal can be used to change demand limit setpoint through either 0-10VDC or 4-20mA signals. Operation is described in document CNT-SVU006.

# Communication Interface Options

## Percent capacity output

The controller provides an analog voltage output (0-10 VDC) to communicate active unit capacity [%]. This signal is available on option module Additional details are present in document CNT-SVU006.

## General

**WARNING Ground wire!** All field-installed wiring must be complete by qualified personnel, and comply with the local codes and regulations. Failure to follow this instruction could result in death or serious injury.

Field wiring for the communication link must meet the following requirements:

- All wiring must be in accordance with local codes and regulations.
- Communication link wiring must be shielded, twisted pair wiring (Belden 8760 or equivalent), below table provides recommendation for wire size selection:
- The communication link cannot pass between buildings
- All units on the communication link can be connected in a "daisy chain" configuration.

**Note: to prevent control malfunctions, do not run low voltage wiring (< 30 V) in conduit with conductors carrying more than 30 V.**

**Table 5 - Wire Size**

Ø	Wire Size Maximum Length of Communication Wire
2.5 mm <sup>2</sup>	1525 m
1.5 mm <sup>2</sup>	610 m
1.0 mm <sup>2</sup>	305 m

Additional details are present in document CNT-SVU006



# Operating Principles

This section contains an overview of the operation of CGAX and CXAX air cooled chillers, microprocessor based unit control modules Tracer™ Symbio800 control systems.

**Note:** *To ensure proper diagnosis and repair, contact a qualified service organization if a problem should occur.*

## General

CGAX and CXAX chillers are scroll compressor, single or dual circuit air-cooled chillers. These units are equipped with unit-mounted starter/control panels and operate with R410A refrigerant.

The basic components on the CGAX/CXAX are:

- Unit-mounted panel containing starter and unit controller
- Scroll compressors
- Brazed plate evaporator
- Air-cooled condenser with sub-cooler
- Electronic expansion valve
- Related interconnecting piping

## Refrigerant Cycle

Refrigerant cycle is similar to other Trane Scroll compressor chillers. Conquest chillers use brazed plate evaporator and air-cooled condenser. Compressors use suction gas cooled motors and an oil management system to provide almost oil-free refrigerant to the condenser and evaporator for maximum heat transfer while lubricating and sealing compressor rotors and bearings. The lubrication system helps to assure long compressor life and contributes to quiet operation.

Liquid refrigerant coming from the condenser coils, are metered into the brazed plate evaporator using an electronic expansion valve to maximize chiller efficiency at full and part load operation.

Chillers are equipped with a unit-mounted starter and control panel. Microprocessor based unit control module Tracer™ Symbio800 controller provides accurate chilled water control monitoring, protection and limit functions. If problems occurs the unit controller provide diagnostic messages to help the operator in troubleshooting.

# Operating Principles

This section describes the overall operating principle of the CGAX design (duplex cooling unit).

**Figure 9a - Example of Typical Refrigerant System Schematic of duplex cooling only unit**

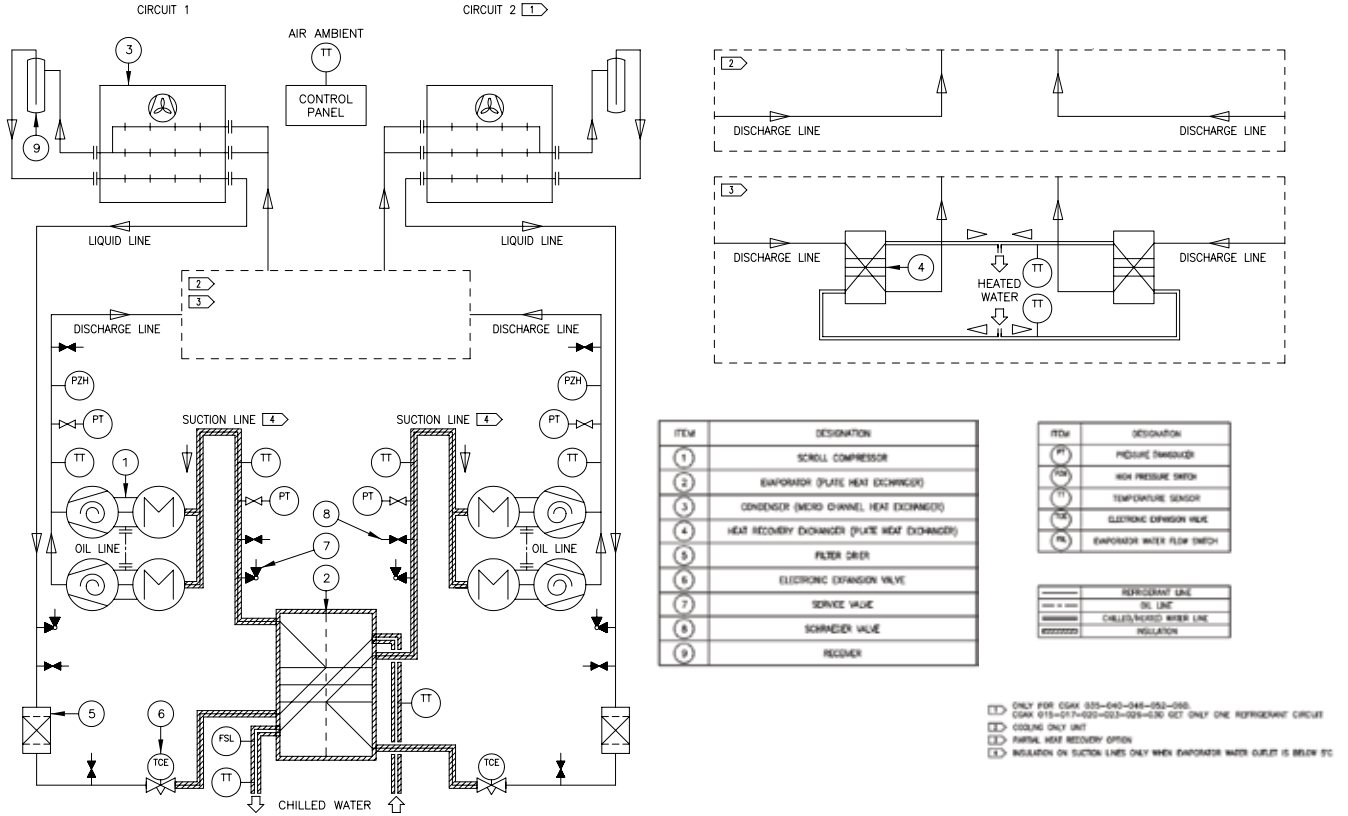

ITEM	DESIGNATION
1	SCROLL COMPRESSOR
2	EVAPORATOR (PLATE HEAT EXCHANGER)
3	CONDENSER (WIND COOLING HEAT EXCHANGER)
4	HEAT RECOVERY EXCHANGER (PLATE HEAT EXCHANGER)
6	FILTER DRIER
8	ELECTRONIC EXPANSION VALVE
7	SERVICE VALVE
9	SCHRADER VALVE
9	RECHARGE

ITEM	DESIGNATION
PT	PRESSURE TRANSDUCER
PZH	HIGH PRESSURE SWITCH
TT	TEMPERATURE SENSOR
EV	ELECTRONIC EXPANSION VALVE
EWFS	EVAPORATOR WATER FLOW SWITCH

LINE STYLE	DESIGNATION
(Solid line)	REFRIGERANT LINE
(Dashed line)	OIL LINE
(Dotted line)	CHILLED/HEATED WATER LINE
(Hatched area)	INSULATION

[Symbol] ONLY FOR CGAX 020-040-048-050-058  
 [Symbol] CGAX 010-014-020-023-026-030 SET ONLY ONE REFRIGERANT CIRCUIT  
 [Symbol] COOLING ONLY UNIT  
 [Symbol] PARTIAL HEAT RECOVERY OPTION  
 [Symbol] INSULATION ON SUCTION LINES ONLY WHEN EVAPORATOR WATER OUTLET IS BELOW 0°C

## Operating Principles

**Figure 9b - Example of Typical Refrigerant System Schematic of simplex large trio cooling only unit**

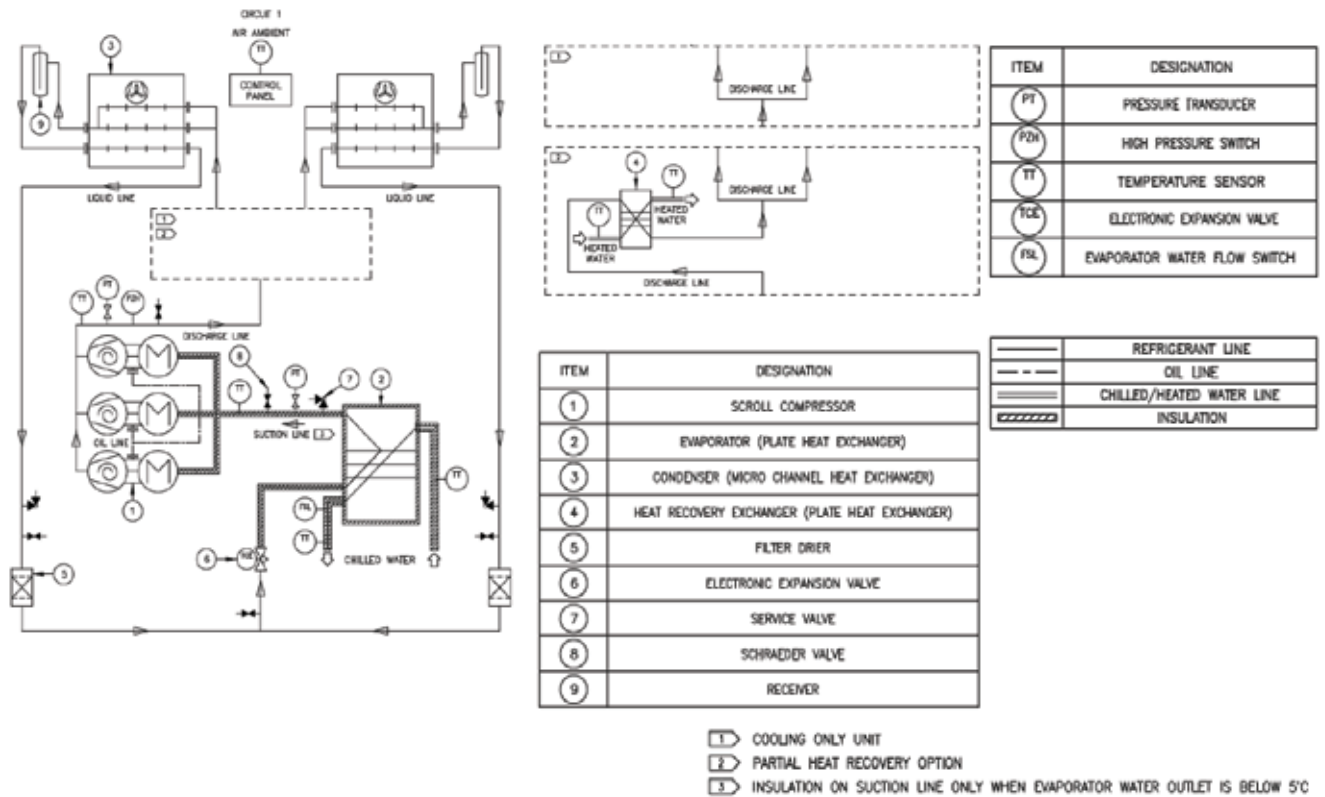

# Operating Principles

This section describes the overall operating principle of the CXAX design (Duplex Heating pump unit).

**Note:** Due to unit design there is no need to validate oil cycle while operating a reversible unit a long time in cooling mode

**Figure 10a - Example of Typical Refrigerant System Schematic of duplex heat pump unit**

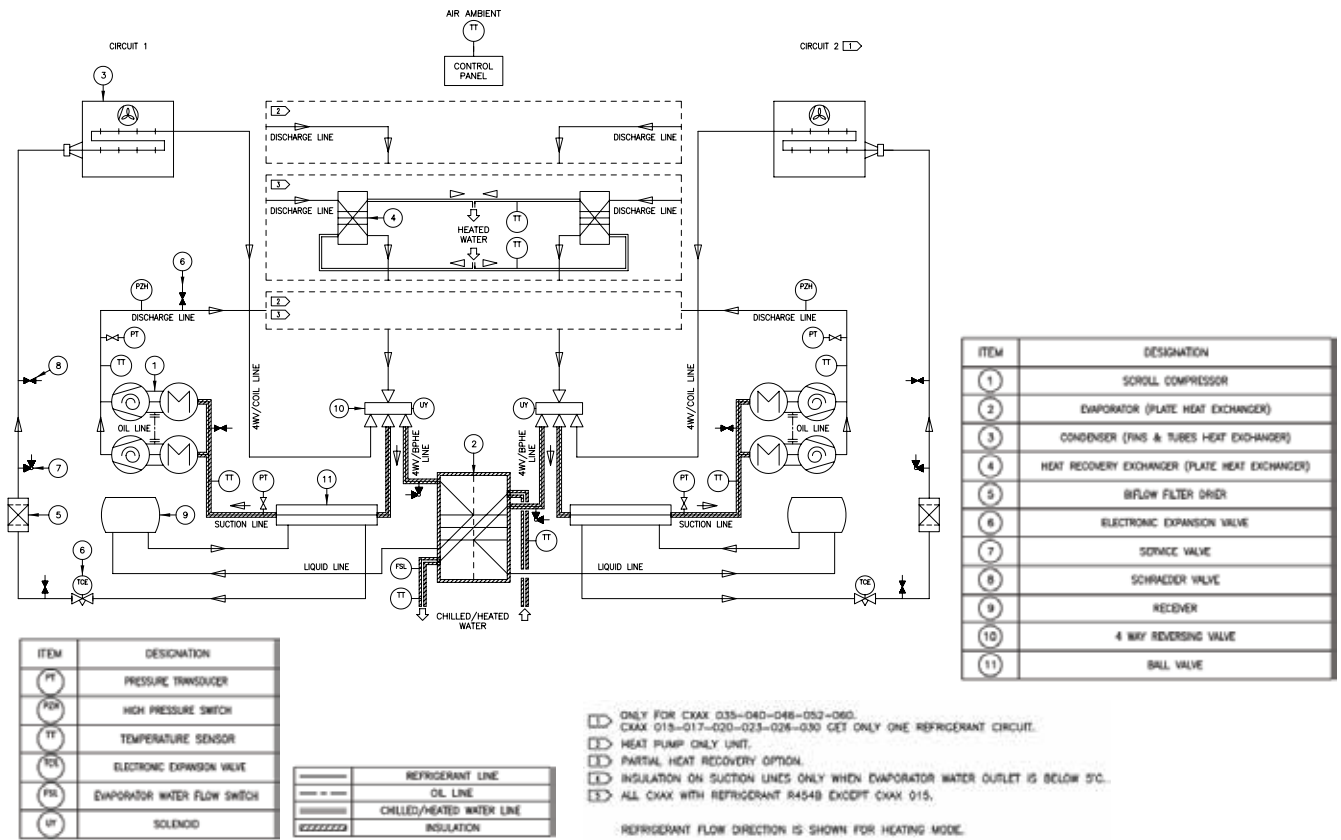

# Operating Principles

Figure 10b - Example of Typical Refrigerant System Schematic simplex large trio heat pump unit

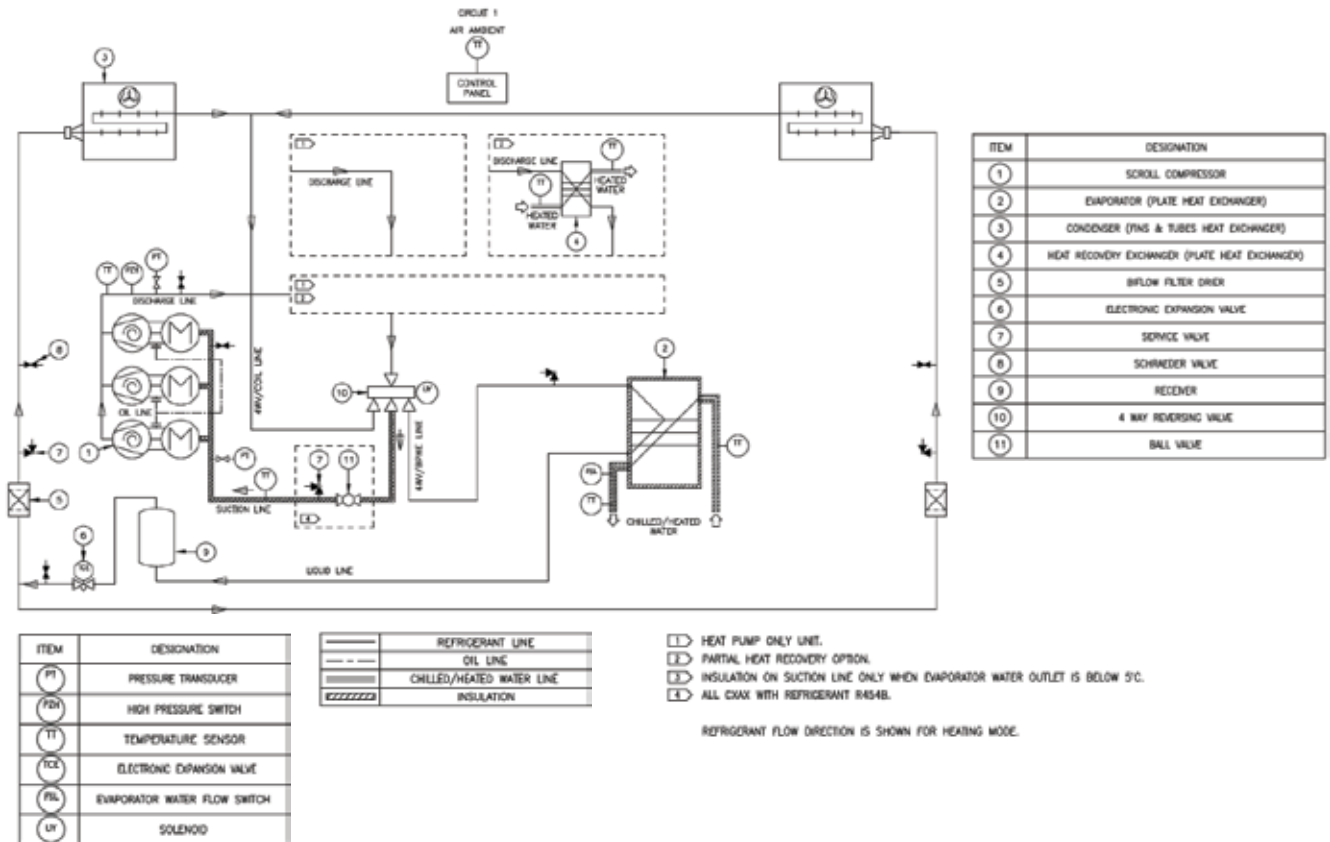

## Operating Principles

### Oil System

The oil is efficiently separated inside the scroll compressor and will remain in the scroll compressor during all run cycles. Between 1-2% of the oil circulates around with the refrigerant. See on the compressor section for oil level information.

### Hydraulic Module water charts

Figure 11 - Hydraulic Module water chart - unit without pump package

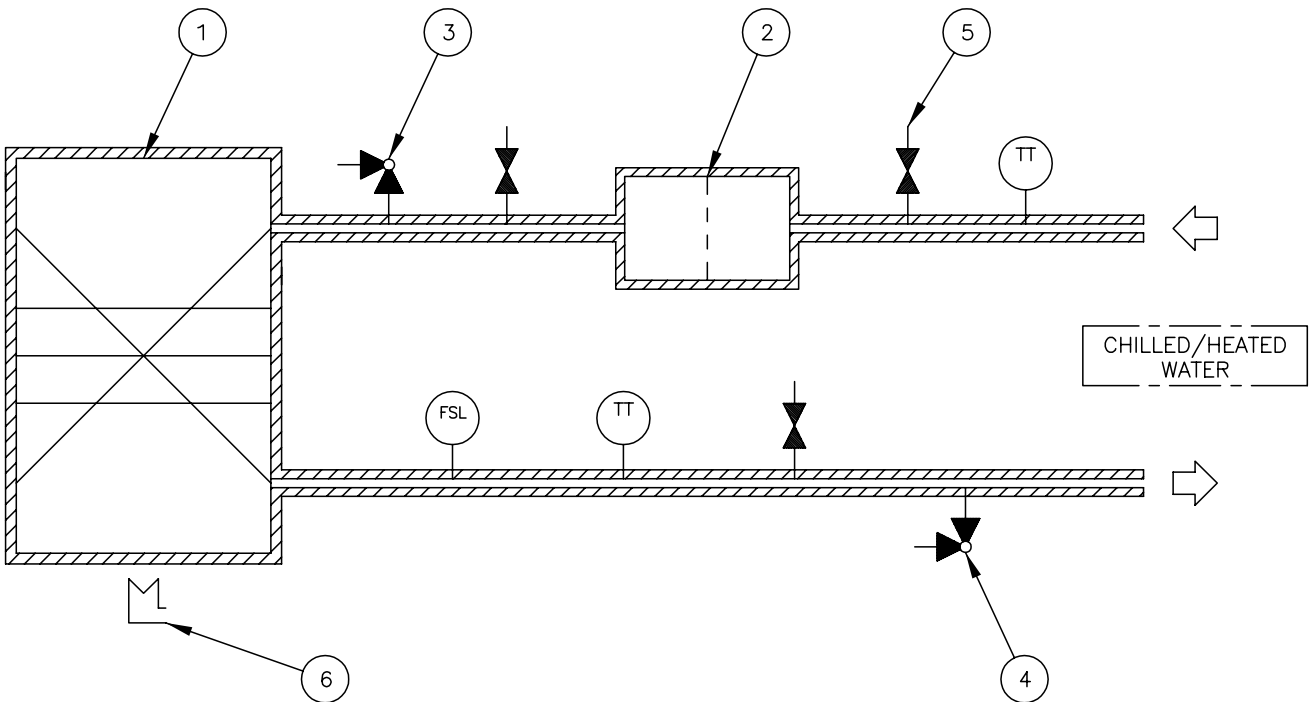

ITEM	DESIGNATION
①	EVAPORATOR (PLATE HEAT EXCHANGER)
②	WATER STRAINER
③	MANUAL AIR BLEED
④	DRAIN VALVE
⑤	VALVE FOR PRESSURE POINT
⑥	ANTIFREEZE PROTECTION (OPTION)

ITEM	DESIGNATION
TT	TEMPERATURE SENSOR
FSL	EVAPORATOR WATER FLOW SWITCH

	CHILLED/HEATED WATER LINE
	INSULATION

# Operating Principles

Figure 12 - Hydraulic Module water chart - unit with pump package

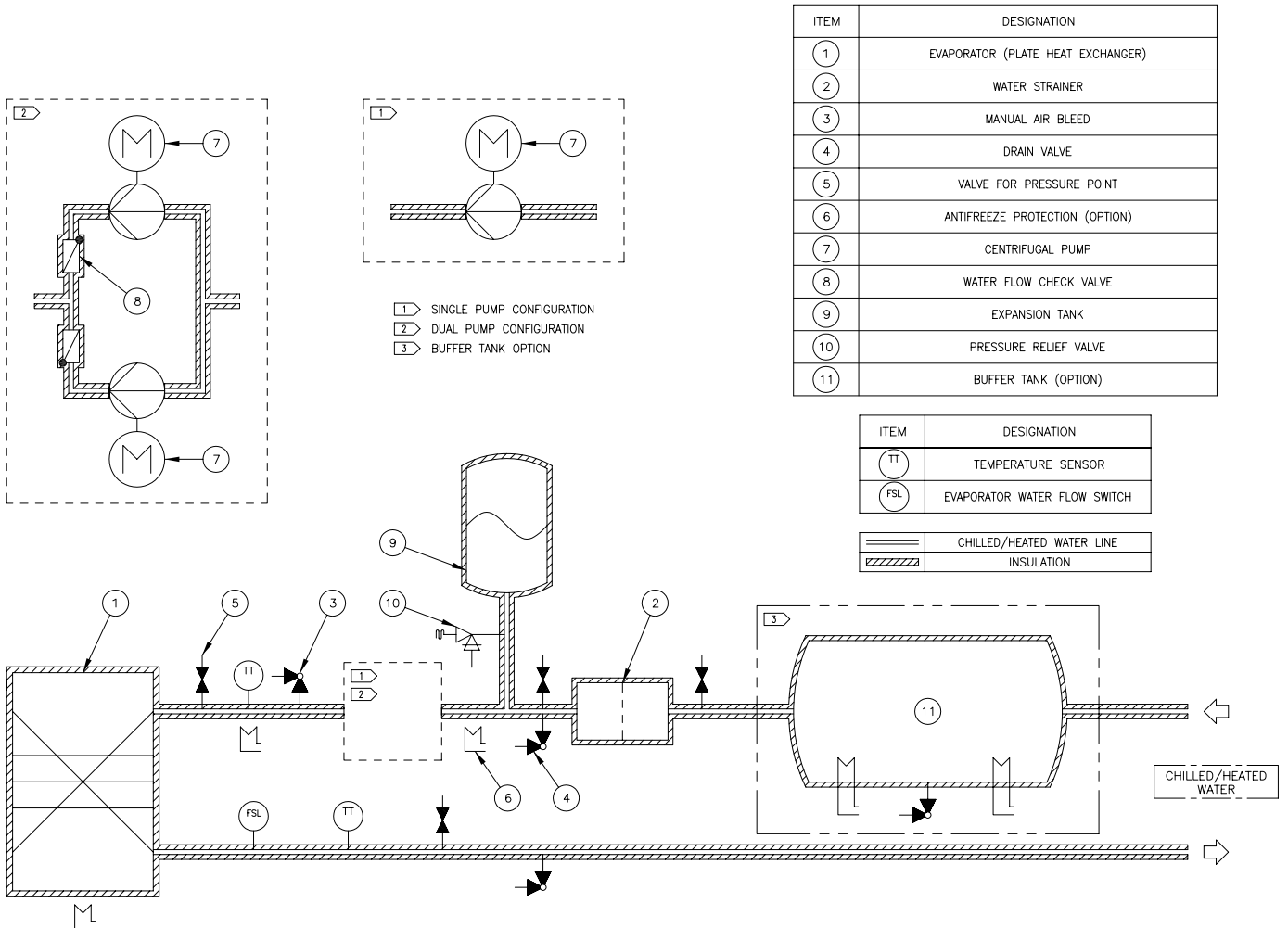

# Variable Primary Flow

Impact on unit design :

Add either differential pressure sensor or 2 water temperatures sensor.

Pump selection remains unchanged.

A variable speed drive to be added into the control box.

2 or 3 options of variable water flow :

Manual flow adjustment

Constant delta T

## VPF Constant delta T:

Principle :

If 1 Compressor switch off then Delta T decrease --> pump speed decrease.

If 1 Compressor switch On then Delta T increase --> pump speed increase.

Min pump speed = 30Hz

Require 3 ways valve on customer side.

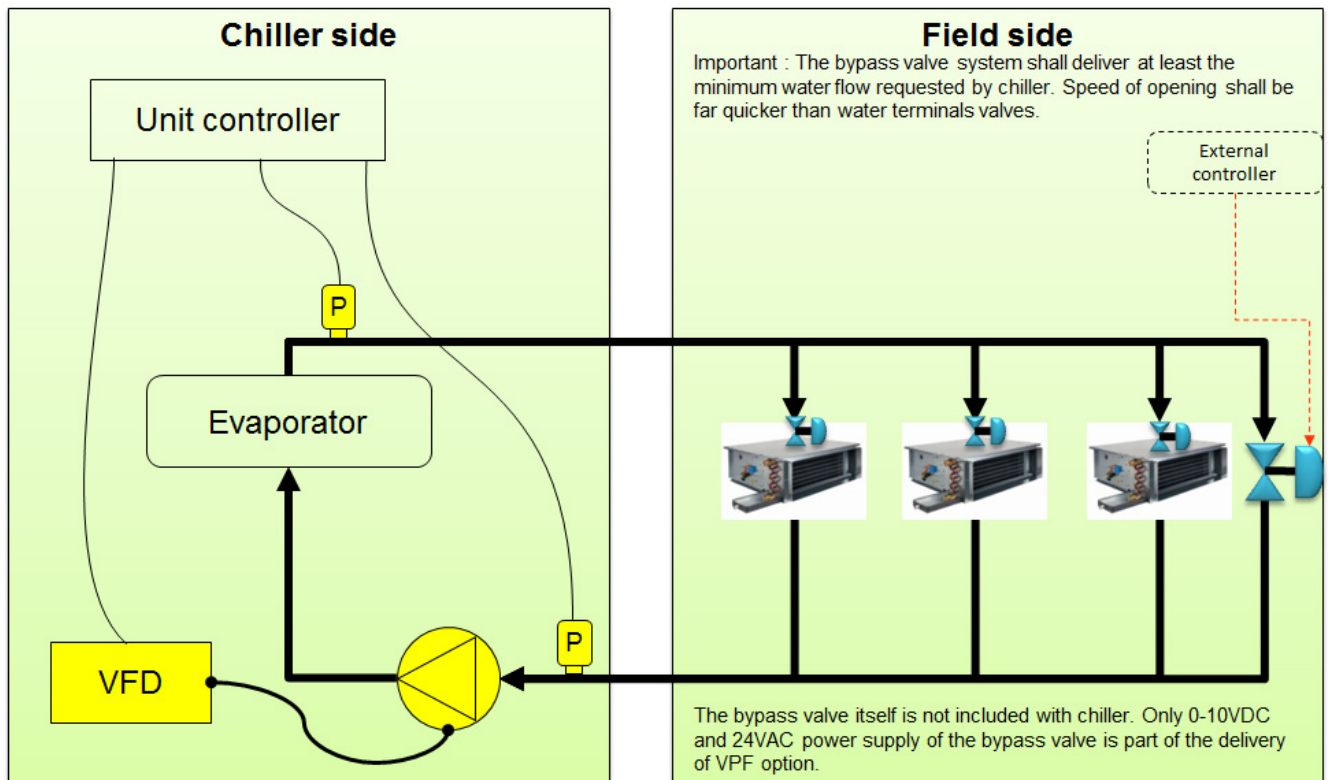



# Controls/Tracer TD7 Operator Interface

## Controls Overview

Conquest CGAX / CXAX units use the following control/ interface components:

- Tracer™ UC800/Symbio800 Controller
- Tracer TD7 Operator Interface

## Communication Interfaces

There are four connections on the Tracer™ UC800/ Symbio800 that support the communication interface :

- BACnet MS/TP
- BACnet IP (Only with Symbio800)
- MODBUS RTU
- MODBUS TCP (Only with Symbio800)

## Tracer TD7 Operator Interface

### Operator Interface

Information is tailored to operators, service technicians and owners. When operating a chiller, there is specific information you need on a day-to-day basis, like set points, limits, diagnostic information, and reports. Day-to-day operational information is presented at the display. Logically organized groups of information-chiller mode of operation, active diagnostics, settings and reports put information conveniently at your fingertips.

### Tracer™ TU

The TD7 operator interface allows for daily operation tasks and set point changes. However to adequately service Conquest CGAX chillers / CXAX Heat Pump, Tracer™ TU service tool is required (Non-Trane personnel, contact your local Trane office for software purchase information). Tracer TU adds a level of sophistication that improves service technician effectiveness and minimizes chiller downtime. This portable PC-based service-tool software supports service and maintenance tasks



# General Start up

## Start Up Preparation

Carry out all operations on check list so that the unit is correctly installed and ready to operate. The installer must check all the following points before calling in Trane Service to put the equipment into service:

- Check position of unit.
- Check unit is level.
- Check type and position of rubber pads.
- Check clearance required for maintenance access (Refer to certified drawings).
- Check clearance around condenser (Refer to certified drawings).
- Chilled water circuit ready to operate, filled with water, pressure test carried out and air purged.
- Chilled water circuit must be rinsed.
- Check the presence of water strainer ahead of evaporator.
- The strainers must be cleaned after 2 hours of pumps operation.
- Check the thermometers and manometers position.
- Check chilled water pumps interconnection to control panel.
- Open the vent on the pump body to fill the pump with water.
- Ensure that the isolation resistance of all power supply terminals to ground complies with standards and regulations in force.
- Check that unit voltage and frequency supplied match rated input voltage and frequency.
- Check that all electrical connections are clean.
- Check that main power supply switch is sound.
- Check the unit power phasing to be sure that it has been installed in an "ABC" sequence.
- Check Ethylene glycol or Propylene glycol % in the chilled water circuit.
- Water flow control checking: decrease the water flow and check the electrical contact in the control panel.
- Check chilled water pressure drop through evaporator (unit without hydraulic module) or unit available pressure (unit with hydraulic module) are in accordance with the Trane order write-up (See graphics.....).
- On start-up of each motor in the system, check the direction of rotation and operation of all the components they drive.
- Check that there is enough demand for cooling on the day of the start-up (around 50% of the nominal load as minimum).
- When ball valve is present on the refrigerant suction line, to check if the valve is open before starting the unit.
- Check and set, as required, all Tracer™ Symbio800 TD7 menu items

### Water System Flow Rates

Establish a balanced chilled water flow through the evaporator. The flow rates must fall between the minimum and maximum values. Chilled water flow rates below the minimum values will result in laminar flow, which reduces heat transfer and causes either loss of EXV control or repeated nuisance, low temperature cutouts.

**Water System Pressure Drop Measure** water pressure drop through the evaporator at the field-installed pressure taps on the system water piping. Use the same gauge for each measurement. Measure flow at the field-installed supply and return. This will include valves, strainers, and fittings in the pressure drop readings. Pressure drop readings should be approximately those shown in the Pressure Drop Charts in the Installation-Mechanical section.

### WARNING Hazardous Voltage!

Disconnect all electric power, including remote disconnects before servicing. Follow proper lockout/tagout procedures to ensure the power can not be inadvertently energized. Failure to disconnect power before servicing could result in death or serious injury.

### Time before working on the electrical panel of the unit with Low Ambient option

**Once the unit is off (confirmed by the extinction of the display), it is mandatory to wait five minutes before working on the electrical panel. Refer unit manual (Addendum\_PROD-SVX01) for electrical components safety instructions.**

### WARNING Live Electrical Components!

During installation, testing, servicing and troubleshooting of this product, it may be necessary to work with live electrical components. Have a qualified licensed electrician or other individual who has been properly trained in handling live electrical components perform these tasks. Failure to follow all electrical safety precautions when exposed to live electrical components could result in death or serious injury

**CAUTION!** When using freeze inhibitor, never fill the system with pure glycol. Always fill the system with diluted solution. Maximum concentration of Glycol is 40%. Higher glycol concentration will damage pump seal.

**CAUTION!** The pump must not run dry. Dry-running will damage the mechanical seal.

**CAUTION!** Proper Water Treatment! The use of untreated or improperly treated water in the chiller may result in scaling, erosion, corrosion, algae or slime. It is recommended that the services of a qualified water treatment specialist be engaged to determine what water treatment, if any, is required. Trane assumes no responsibility for equipment failures which result from untreated or improperly treated water, or saline or brackish water.

**CAUTION!** Strainer should be cleaned after water flow has been established for the first time, as it is likely that it collects all the particles left after field installation.

## General Start up

### Start Up

Follow the instructions below to correctly start-up the unit.

#### Installation and chiller inspection

- Ensure that all the operations above (start-up preparation), are followed. Follow the instruction stuck inside the electrical cabinet
- Put the plexiglass supplied by Trane in front of the power terminal
- Ensure all water and refrigerant valves are in service positions. When ball valve is present on the refrigerant suction line, to check if the valve is open before starting the unit.
- Ensure that the unit is not damaged
- Ensure that sensors are properly installed in their bulb-wells and submerged in heat conducting product
- Check fixing of capillary tubes (protection from vibration and from wear) and ensure that they are not damaged
- Reset all manually set control devices
- Check refrigerating circuits tightness

#### Checking and setting

##### Compressors

- Check oil level at rest. The level should reach at least halfway up indicator located on housing. See Figure 16 for correct level.

**Figure 13 - Compressor oil level**

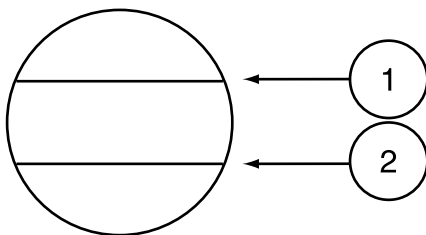

1 = Max. oil level

2 = Min. oil level

- Reset all manually set control devices
- Check refrigerating circuits tightness
- Check electrical terminals tightening of the motors and in the control panel
- Check the isolation of the motors using a 500V DC megohmmeter which meets manufacturer's specifications (minimum value 2 megohms)
- Check the direction of the rotation using phasemeter

#### Electrical power wiring

- Check all the electrical terminals tightening
- Set-up compressors overload relays
- Set-up fan-motors overload relays

#### Electrical control wiring

- Check all the electrical terminals tightening
- Check all the pressostats
- Check and set-up the chiller unit control module
- Test and start-up without the electrical power

#### Condenser

- Check direction of the rotation of fans
- Check the isolation of the motors using a 500V DC megohmmeter which meets manufacturer's specifications (minimum value 500 megohms)

#### Operating parameters statement

- Switch on main power supply switch
- Start the water pump(s) and check there is no cavitation
- Start-up the unit following procedure described in the CH535 controller user guide. The unit and the chilled water pumps contactor must be connected together
- After unit start up, leave in operation for at least 15 minutes, to ensure pressures are stabilized

#### Then check:

- voltage
- compressors and fan-motors currents
- leaving and return chilled water temperature
- suction temperature and pressure
- ambient air temperature
- blowing air temperature
- discharge pressure and temperature
- liquid refrigerant temperature and pressure
- operating parameters
  - chilled water pressure drop through evaporator (if no hydraulic module is installed) or unit available pressure. It must be in accordance with Trane order write-up
  - superheat: difference between suction temperature and dew point temperature. Normal superheat should be within 5 and 7 °C with R410A in cooling mode
  - sub-cooling: difference between liquid temperature and bubble point temperature. Normal sub-cooling should be within 2 and 15°C with R410A in cooling mode
  - difference between dew point temperature in high pressure and condenser air inlet temperature. Normal value on standard unit with R410A should be 15 to 23°C
  - difference between outlet water temperature and dew point temperature in low pressure. Normal value on standard unit, without Ethylene glycol in chilled water, should be about 3.5°C

## General Start up

### Final check

When the unit is operating correctly:

- Check that the unit is clean and clear of any debris, tools, etc...
- All valves are in operating position
- Close control and starter panel doors and check panels fixation

### Tracer™ Symbio800 Set-Up

Using Tracer TU service tool, adjust the settings. Refer to Tracer TU manual and Tracer™ Symbio800 user guide for instruction on settings.

### CAUTION!

- For the warranty to apply, any start-up carried out directly by the customer must be recorded in a detailed report, which must be sent as soon as possible to the nearest Trane office.
- Do not start-up a motor whose insulation resistance is less than 2 megohms
- Phase imbalance should not be greater than 2%
- The voltage supplied to motors should be within 5% of the rated voltage on the compressor nameplate.
- Excessive emulsion of the oil in the compressor shows that refrigerant is present in the oil and the result will be that compressor is not lubricated enough.. Shut down compressor and wait for 60 minutes for the sump heaters to heat oil and start again. Should this not work, consult Trane technician.
- Excess oil in compressor can damage the compressor. Before adding oil, consult Trane technician. Use only Trane products recommended.
- The compressors must operate in a single direction of rotation. If refrigerant high pressure remains stable in the 30 seconds after compressor start-up, immediately shut down unit and check the direction of rotation using phasemeter.

### WARNING!

- The chilled water circuit may be under pressure. Bring down this pressure before opening up the system to rise out or fill up the water circuit. Failure to comply with this instruction may cause accidental injury to maintenance personnel.
- If a cleaning solution is used in the chilled water circuit, the chiller must be isolated from the water circuit to avoid all the damage risks of the chiller and evaporator water pipes.

## Pre-Start Check List (Sample)

<b>UNIT</b>	
	Check clearance around condenser
	Check clearance required for maintenance access
	Check type and position of the rubbers pads
	Check unit is level
<b>CHILLED WATER CIRCUIT</b>	
	Check thermometers and manometers presence and position
	Check water flow rate balancing valve presence and position
	Check presence of strainer ahead the evaporator
	Check presence of air-purge valve
	Check rinsing and filling of chiller water pipes
	Check water pump(s) contactor interconnected to control panel
	Check water flow
	Check chilled water pressure drop or unit available pressure (units with hydraulic module)
	Check for leaks in chilled water pipes
<b>ELECTRICAL EQUIPMENT</b>	
	Check installation and rating of mains power switch/fuses
	Check electrical connections complied with specification
	Check that electrical connections are in accordance with information on manufacturer's identification plate
	Check direction of rotation using phasemeter
<b>Comments</b>	
<b>Name</b>	
<b>Signature</b>	
<b>Order Number</b>	
<b>Job site</b>	

# Operation

## Control System

Unit operation is intergrally managed by the microprocessor-based unit Tracer™ Symbio 800 controller.

## Unit Operation

- Check that the chilled water pump(s) operates correctly
- Start up the unit following procedure described in the unit controller user guide. The unit will operate correctly when there is sufficient water flow. The compressors will start up if the evaporator water leaving temperature is above the control module setpoint.

## Weekly start up

- Check that the chilled water pump(s) operates correctly
- Start up the unit following procedure described in the unit controller user guide

## Weekend shutdown

- If the unit needs to be shut down for a short period of time, stop the unit following procedure described in the unit controller user guide. (See «Clock» menu)
- If the unit is shut down for a longer period, see under «Seasonal shutdown», below
- Ensure that all safeties are taken to prevent frost damages during negative ambient temperature
- Do not put the general disconnect switches to off, except if the unit is drained. Trane does not recommend draining the unit, due to the fact that it increases corrosion

## Seasonal shutdown

- Check water flows and interlocks
- Check glycol % in the chilled water circuit if glycol presence is required
- Carry out leak test
- Carry out oil analysis
- Record operating pressures, temperatures, amperages and voltage
- Check operation of machines/ compare conditions of operation against original commissioning data
- Stop the unit following procedure described on the unit controller user guide
- Ensure that all safeties are taken to prevent frost damages during negative ambient temperature
- Fill out the visit log sheet and review with the operator - Do not put the general disconnect switch to off, except if the unit is drained
- Trane does not recommend draining the unit, due to the fact that it increases corrosion

## Seasonal start-up

- Check water flows and interlocks
- Check Ethylene glycol % in the chilled water circuit if glycol presence is required
- Check operational setpoints and performance
- Calibrate controls
- Check operation of all safety devices
- Inspect contacts and tighten terminals.
- Megger the motor compressor windings
- Record operating pressures, temperatures, amperages and voltage
- Carry out leak test
- Check configuration of unit control module
- Change the oil as required based upon results of the oil analysis made during seasonal shutdown Get the 8 condition measurements at the same time, on each circuit
  - HP
  - LP
  - Suction temperature
  - Discharge temperature
  - Liquid temperature
  - Water entering temperature
  - Water leaving temperature
- Outdoor ambient temperature Then calculate the sub-cooling and superheat. No diagnosis can be accurate with one of these recordsmissing
- Check operation of machines/compare conditions of operation against original commissioning data
- Fill out the visit log sheet and review with the operator

# Maintenance

## Maintenance Instructions

The following maintenance instructions are part of maintenance operations required for this equipment. A qualified technician is needed for regular maintenance as part of a regular maintenance contract. Carry out all operations as required by schedule. This will ensure long unit service life and reduce the possibility of serious and costly breakdown. Keep service records up to date, showing monthly information on unit operations. These records can be of great help to maintenance personnel diagnostics.

Similarly, if machine operator keeps a log of changes in unit operating conditions, problems can be identified and solutions found before more serious problems arise.

### Inspection visit after the first 500 hours of operation from unit start up

- Carry out oil analysis
- Carry out leak test
- Inspect contacts and tighten terminals
- Record operating pressures, temperatures, amperages and voltage
- Check operation of machines/ compare conditions of operation against original commissioning data
- Fill out inspection visit log sheet and review with the operator
- Check and clean the strainer

### Monthly preventive visit

- Carry out leak test
- Oil test of acidity
- Check Ethylene glycol % in the chilled water circuit if glycol presence is required
- Inspect contacts and tighten terminals
- Record operating pressures, temperatures, amperages and voltage
- Check operation of machines/ compare conditions of operation against original commissioning data
- Fill out visit log sheet and review with the operator
- Check and clean the water strainer

### Annual preventive visit

- Check water flows and interlocks
- Check expansion tank pressure
- Check glycol % in the chilled water circuit if glycol presence is required
- Check operational setpoints and performance
- Calibrate controls and pressure transducer
- Check operation of all safety devices
- Inspect contacts and tighten terminals
- Megger the motor compressor windings
- Record operating pressures, temperatures, amperages and voltage
- Carry out leak test
- Check configuration of unit control module
- Carry out oil analysis
- Change the oil as required based upon results of the oil analysis
- Check operation of machines/ compare conditions of operation against original commissioning data
- Fill out the annual start up visit log sheet and review with the operator
- Check and clean the water strainer

### CAUTION!

- Refer to specific Trane documentation on oil, available from your nearest Trane office. Oils recommended by Trane have been exhaustively tested in Trane laboratories to the specific requirement of Trane chiller and hence the user's requirements. Any use of oils not meeting specifications recommended by Trane is the responsibility of the user only, who thereby is liable to warranty loss.
- Oil analysis and oil test acidity must be carried out by a qualified technician. Poor interpretation of results may cause unit operating problems. Also, oil analysis must follow the correct procedures, to avoid accidental injury to maintenance personnel.
- If the condensers are dirty, clean them with a soft brush and water. If the coils are too dirty, consult a cleaning professional. Never use high pressure water to clean condenser coils.
- Contact Trane Service for information on maintenance contracts.

### WARNING!

- Switch off unit main power supply before to any intervention. Failure to follow this safety instruction can lead to accident death of the maintenance personnel and may also destroy equipment.
- Never use steam or hot water above 60°C to clean condenser coils. The resulting increasing pressure could cause refrigerant lost through the safety valve.

**Refer unit manual (Addendum\_PROD-SVX01-GB) for Operation/Maintenance/Repair/Unit modification.**



## Maintenance

### Pump maintenance

Pumps motor bearings and mechanical seals have a designed life expectancy of 20000-25000 hours of operation. For critical applications it might be necessary to change the components as a preventive measure.

## Compressors Service Information

### Oil Equalizer line

#### CSHD Compressors

The oil equalizer line is equipped with a Rotolock fitting for easy removal. Torque value for tightening these fitting is 90 N.m. Before removing the oil equalizer line, the system refrigerant charge must be recovered before draining the oil. Use a catch pan to catch the oil when the compressor oil equalizer line is loosened to ensure that oil does not spill out of the compressor when the equalizer line is removed.

#### Tandem and Trio Compressor Suction Restrictors

Since most uneven tandem and trio compressor sets require the use of a restrictor in the suction line of one or more compressors in order to provide correct oil level balance between compressors when they are operating.

## Compressor Replacement

If the CGAX/CXAX chiller suffers a failed compressor, use these steps for replacement:

Each compressor has lifting eyes. Both lifting eyes must be used to lift the failed compressor. **DO NOT LIFT A COMPRESSOR USING A SINGLE LIFTING EYE.** Use proper lifting techniques, a spreader bar and rigging as for lifting both compressors simultaneously.

Compressor weights by compressor model are:

DSH 092 – 58 kg.

DSH 125 – 64 kg.

DSH 142 – 67 kg.

DSH 161 – 69 kg.

DSH 183 – 76 kg.

After a mechanical failure of a compressor, it is necessary to change the oil in the remaining compressor and also replace the liquid line filter drier. After an electrical failure of a compressor, it will also be necessary to change the oil in the remaining compressor, replace the liquid line filter drier and add a suction filter drier with cleanup cores.

**Note:** Do not alter the refrigerant piping in any way as this can affect compressor lubrication.

**Note:** Do not add a suction filter drier within 250mm of the elbow for CSHD compressors.

## Refrigerant System Open Time

Model CGAX/CXAX chillers use POE oil (Trane recommended oil OIL 048E or OIL 023E) and therefore refrigerant system open time must be kept to a minimum. The following procedure is recommended:

- Leave a new compressor sealed until it is ready to be installed in the unit. Maximum system open time is dependent upon ambient conditions, but do not exceed one hour open time.
- Plug the open refrigerant line to minimize moisture absorption. Always change the liquid line filter drier.
- Evacuate the system to 500 microns or below.
- Do not leave POE oil containers open to the atmosphere. Always keep them sealed.

## Mechanical Compressor Failure

Replace the failed compressor(s) and change the oil in the remaining compressor(s) along with the refrigerant system liquid line filter drier.

## Electrical Compressor Failure

Replace the failed compressor and change the oil in the other compressor(s). Also add a suction filter with cleanup cores and change the liquid line filter drier. Change filters and oil until the oil no longer test acidic. See "Oil Testing."

## Compressor Motor Megging

Motor megging determines the electrical integrity of the compressor motor winding insulation. Use a 500 volt megger. A less than 1 meg-ohm reading is acceptable and 1000 ohms per nameplate volts is required to safely start the compressor.

## Compressor Current Imbalance

Normal current imbalance could be 4 to 15 percent with balanced voltage due to motor design. Each phase should register .3 to 1.0 ohms and each phase should be within 7 percent of the other two phases. Phase to ground resistance must be infinity.

**Note:** Maximum allowable voltage imbalance is 2 percent.



### Refrigerant Piping

The compressor suction and discharge connections and piping are copper clad steel for easy brazing. In most instances, piping may be reused. If piping is not reusable, order the correct service parts. Cut all tubing with a tubing cutter to prevent copper filings from entering the system. Cut the tubing in a straight length of pipe after the compressor connection has been unsweated. The line can then be reinstalled using a slip coupling and brazing.

**Note: The compressor suction line configuration must not be changed in any way. Changing compressor suction line configuration will compromise proper oil return to the compressor(s).**

### Compressor Electrical Terminal Box

Be sure to protect the terminal box when unbrazing or brazing compressor refrigerant piping connections

### Compressor Crankcase Heaters

Compressor crankcase heaters must be energized at least eight hours before starting the chiller. This is required to boil refrigerant out of the oil before startup. Ambient temperature is not a factor and the crankcase heaters must always be energized prior to startup.

### Condenser Maintenance

#### Condenser Coil Cleaning

Clean the condenser coils at least once a year or more frequently if the unit is in a "dirty" environment. A clean condenser coil will help to maintain chiller operating efficiency. Follow the detergent manufacturer's instructions to avoid damaging the condenser coils.

#### Black epoxy coil protection (option on heat pump units)

It is recommended to clean the coils at unit start-up and regularly to obtain optimum protection and life span of the condenser coils. To clean the condenser coils use a soft brush and a sprayer such as a garden pump type or a high pressure type. A high quality detergent such as Trane Coil Cleaner is recommended.

**Note: If detergent mixture is strongly alkaline (pH value greater than 8.5), an inhibitor must be added.**

### Evaporator Maintenance

The Trane Model CGAX liquid chiller uses a brazed plate heat paddle (BPHE) evaporator with factory installed flow switch that is positioned in the evaporator water pipe. The evaporator inlet also includes a water strainer that must be kept in place to keep debris out of the evaporator.

**Note: Strainer maintenance is critical to proper operation and reliability. Any particles larger than 1.6 mm entering the BPHE evaporator may cause the evaporator to fail, requiring replacement.**

Acceptable BPHE evaporator water flow rate is 1.4 to 4.2 l/min per nominal unit kW capacity. To maintain 12-7°C in/out chilled water temperatures, the nominal water flow rate is 2.8 l/min per cooling kW. Minimum water flow rate must be maintained to avoid laminar flow, potential evaporator freezing, scaling and poor temperature control. Maximum water flow is 6 m/s. Flow rates greater than this will cause excessive erosion. The BPHE evaporator is difficult to clean should it become plugged with debris. Indications of a plugged BPHE evaporator include "wet" suction due to lack of heat exchange, loss of superheat control, discharge superheat less than 35°C, compressor oil dilution and/or starvation and premature compressor failure.

### Evaporator replacement

If the CGAX evaporator requires replacement, it is very important that the new evaporator be replaced correctly and with the correct refrigerant and water piping connections. The refrigerant inlet/ liquid connection is at the bottom of the evaporator and the refrigerant outlet/ suction connection is at the top of the evaporator and both are on the same side. Pay particular attention to evaporators with dual circuits. Avoid cross-circuiting when installing the new evaporator.

## Maintenance

### Cleaning Procedures

It is mandatory to clean regularly the coils for a proper unit operation. Eliminate pollution and other residual material help to extend the life of the coils and the unit

**CAUTION! Equipment Damage!** Do not use coil cleaning agents to clean uncoated CGAX coils. Use clean water only. Use of coil cleaning agents on uncoated CGAX coils could cause damage to coils.

Regular coil maintenance, including frequent cleaning-enhances the unit's operating efficiency by minimizing compressor head pressure and amperage draw. The condenser coil (non-coated and e-coated) should be cleaned at least once each quarter or more if the unit is located in a "dirty" or corrosive environment. Cleaning with cleansers or detergents is strongly discouraged due to the all-aluminum construction; straight water should prove sufficient. Any breach in the tubes can result in refrigerant leaks

**Important:** Only in extreme cases should any type of chemical cleaner or detergent be used on micro channel coils. If it becomes absolutely necessary because water alone did not clean the coil, specify a cleaner that is:

- A is pH neutral cleaner.
- An alkaline cleaner that is no higher than 8 on the pH scale.
- An acidic cleaner that is no lower than 6 on the pH scale.
- Does not contain any hydrofluoric acids.

Be sure to follow the instructions provided with any cleaner chosen. Keep in mind that it is still MANDATORY that the coils are thoroughly rinsed with water after the application of the cleaner even if the instructions specify a "No Rinse" cleaner. Cleaners or detergents that are left on the coil due to improper rinsing will significantly increase the possibility of corrosion damage on the micro channel coil.

**Note:** Quarterly cleaning (or more for harsh environment) is essential to extend the life of a MCHE coil and is required to maintain warranty coverage. Failure to clean a MCHE coil will void the warranty and may result in reduced efficiency and durability in the environment.

**WARNING! Hazardous Voltage!** Disconnect all electric power, including remote disconnects before servicing. Follow proper lockout/ tagout procedures to ensure the power cannot be inadvertently energized. Failure to disconnect power before servicing could result in death or serious injury.

1. Disconnect Power to the unit.
2. Wear proper personal protection equipment such as a face shield, gloves and waterproof clothing.
3. Remove enough panels from the unit to gain safe access to the micro channel coil.

**Note:** It is better to clean the coil from the opposite direction of normal air flow (inside of unit out) because this allows the debris to be pushed out rather than forced further into the coil.

1. Use a soft brush or vacuum to remove base debris or surface loaded fibers from both sides of the coil.

**Note:** Remove solid residue is essential to preserve performance of the coil and avoid corrosion over the length of the product life.

2. Using a sprayer and water ONLY, clean the coil following the guidelines below.
  - a. Sprayer nozzle pressure should not exceed 40 bars.
  - b. The maximum source angle should not exceed 25 degrees (Figure 22) to the face of the coil. For best results spray the micro channel perpendicular to face of the coil.
  - c. Spray nozzle should be approximately 5 to 10 cm from the coil surface.
  - d. Use at least a 15° fan type of spray nozzle.

**Figure 14 - Sprayer source angle**

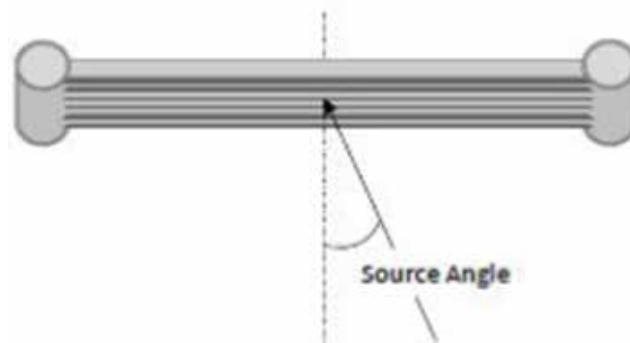

To avoid damage from the spray wand contacting the coil, make sure the 90° attachment does not come in contact with the tube and fin as abrasion to the coil could result.

### Maintenance of Flanges Connection

It is mandatory to apply marine grease all around the coil flange connections to the piping on a regular basis (for instance twice a year) to avoid traps of moisture and dirt in the gasket recess.

### Repair / Replacement of Micro channel Coil

Micro channel coils are considerably more robust in design than tube and fin condenser coils, however they are not indestructible. When damage or a leak occurs in the field, it is possible to temporarily repair the coil until another coil can be ordered.

If the leak is found to be within the tube area of the coil, a field repair kit (KIT16112) is available through your local Trane parts center. Because of the all-aluminum construction and aluminum's high thermal expansion rate, a leak located at or on the header assembly cannot be repaired.

## Water pump maintenance

**WARNING!** Before starting work on the pump, make sure that the power supply has been switched off and that it cannot be accidentally switched on. The internal pump parts are maintenance-free. It is important to keep the motor clean in order to ensure adequate cooling of the motor. If the pump is installed in dusty environments, it must be cleaned and checked regularly. Take the enclosure class of the motor into account when cleaning. The motor has maintenance-free, greased-for-life bearings.

If the water loop must be emptied during period of frost, the pump has to be drained to avoid damage.

Remove the filling and drain plugs.

Do not refit the plugs until the pump is taken into operation again.

**Figure 15 - Water pump plug locations**

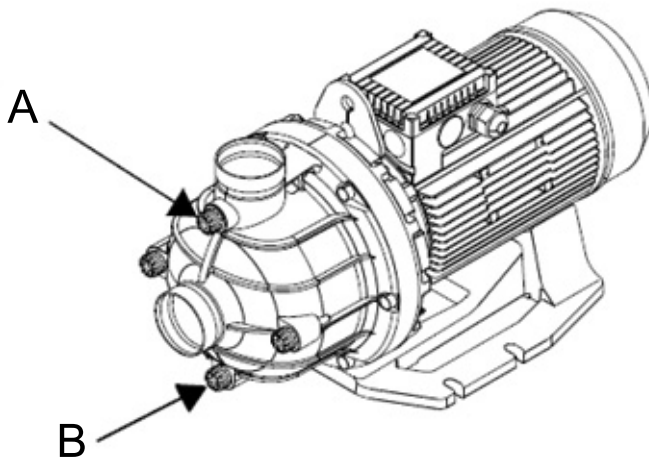

A = Filling plug

B = Drain plug

## Maintenance

### Refrigerant leak detector R454B calibration

Calibration of this component must be done every year. It is important to ensure proper accuracy and operation of the detector. There are two different methods to fulfill the calibration requirements:

#### Replacing the sensor head with a new factory pre-calibrated sensor

It is necessary to make an order of this sensor head as spare part. After sensor head exchange, the detector must be tested with the on-board test button function, which simulates alarm signals and relay activation, to ensure all electrical components are functional.

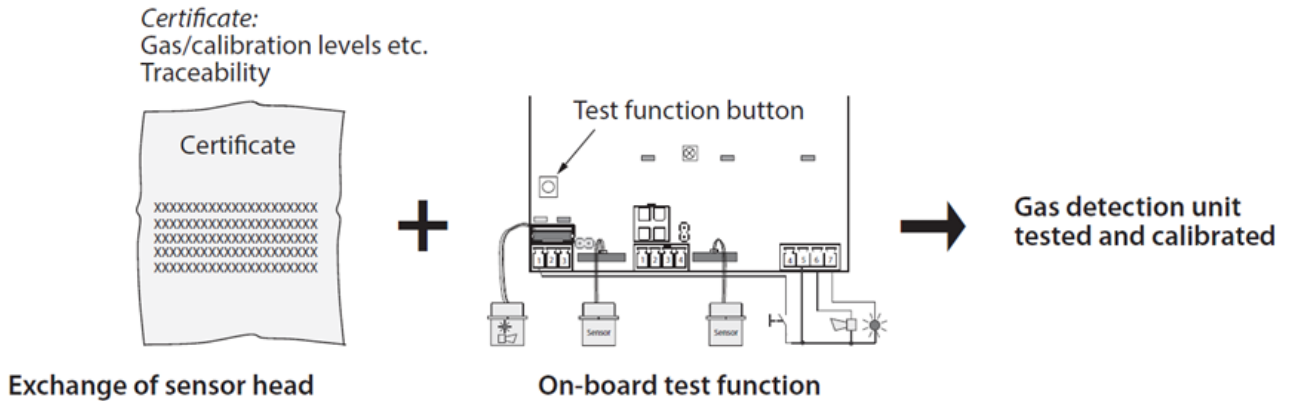

This method is preferred due to the following factors:

- As sensors have a limited lifetime, this method basically ensures that the customer has a gas detector as good as new after replacing the sensor head.
- The method is typically more efficient and cost effective compared to calibration carried out on site.

#### Performing a calibration to the sensor using calibration gas (gas mixture with known target gas concentration)

Test equipment and basic competence in Calibration is required to carry out this method. Calibration equipment for Gas Detection Units (GDU) consists of:

- Valve/Flow regulator.
- Gas cylinder with the correct calibration gas for each refrigerant and concentration (ppm).
- Calibration adapter.

In order to execute the calibration function, the gas detector unit needs to be equipped with a display or connection to either the service tool or the PC tool.

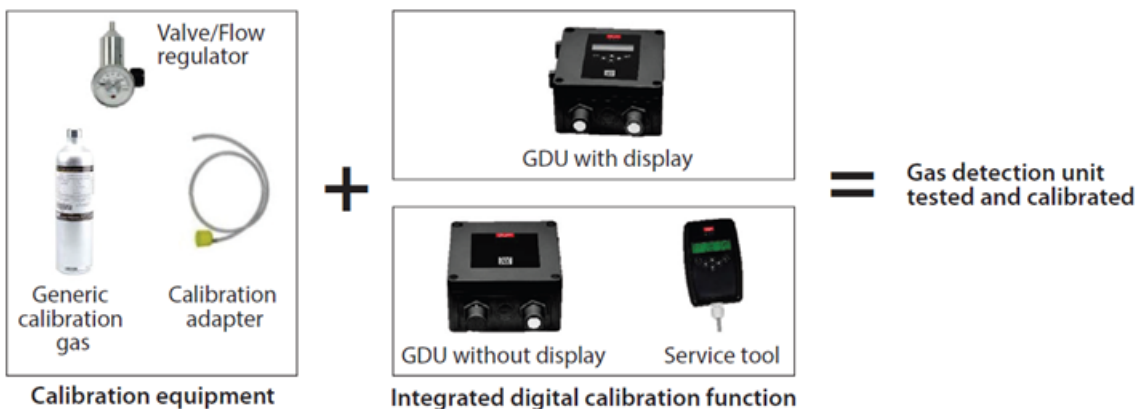

Calibration has to be carried out every year.

# Troubleshooting Guide

This troubleshooting guide is not a comprehensive analysis of the Scroll compressor refrigeration system. The aim is to give operators simple instructions on basic unit processes so that they have the technical knowledge to identify and bring defective operations to the notice of qualified technicians.

Problems Symptoms	Problem causes	Action Recommended
<b>(A) Compressor does not start up</b>		
Compressor terminals are live but motor does not start	Motor burned out	Replace compressor
Contactors motor no operational	Coil burned out or broken contactors	Replace contactor
No current ahead of motor contactor	(a) Power cut (b) Main power supply switched off	Check fuses and connection. See why system tripped. If system is operational, switch on main power supply
Current ahead of fuse, but not on contactor side	Fuse blown	Check motor insulation. Replace fuse
Low Voltage reading on voltmeter	Voltage too low	Contact Power Supply Utility
Starter coil not excited	Regulation circuit open	Locate regulation device which has tripped out and see why. See instructions concerning this device
Compressor does not run. Compressor motor "groans" High pressure switch tripped to contacts open on high pressure. Discharge pressure too high	Compressor sticking (damaged or sticking components) Discharge pressure too high	See instructions for "discharge pressure high"
<b>(B) Compressor stops - Low Pressure switch tripped</b>		
Low refrigerant temperature or low refrigerant pressure cut out Anti-freeze security tripped	Discharge pressure too high. Not enough cooling fluid. Water flow to evaporator too low	See instructions for "Low refrigerant pressure cut out" Repair leak. Add refrigerant. Check water flow rate, and flow switch contact in water
<b>Compressor stops High Pressure switch tripped</b>		
Over current thermal relay tripped Motor temperature thermostat tripped Anti-freeze security tripped	Discharge pressure too high. (a) Voltage too low (b) Cooling demand too high, or condensing temperature too high. (c) Not enough cooling fluid. Water flow to evaporator too low	See instructions for "discharge temperature high" (a) Contact Power Supply Utility (b) Repair leak. Add refrigerant. Check water flow rate, and flow switch contact in water
<b>(C) Compressor stops just after its start</b>		
Suction pressure too low. Filter drier iced up	Filter drier clogged	Replace filter drier
<b>(D) The compressor keeps running without stopping</b>		
Temperature too high in areas requiring air-conditioning	Excess load on cooling system	Check thermal insulation and air-tightness of areas requiring air-conditioning
Chilled water temperature output too high	Excess cooling demand on system	Check thermal insulation and air-tightness of areas requiring air-conditioning

## Troubleshooting Guide

Problems Symptoms	Problem causes	Action Recommended
<b>(E) Loss of oil in compressor</b>		
Oil level too low in indicator	Not enough oil	Contact Trane office before ordering oil
Gradual fall in oil level	Filter drier clogged	Replace filter drier
Suction line too cold. Compressor noisy	Liquid flows back to compressor	Adjust superheat and check bulb fixing of the expansion valve
<b>(F) Compressor noisy</b>		
Compressor knocks	Components broken in compressor	Change compressor
Suction duct abnormally cold	(a) Uneven liquid flow (b) Expansion valve locked in open position	(a) Check superheat setting (b) Repair or replace EXV
<b>(G) Insufficient cooling capacity</b>		
Expansion valve "whistles"	Not enough refrigerant	Check refrigerant circuit tightness and add refrigerant
Excess pressure drops through filter drier	Filter drier clogged	Replace filter drier
Excessive superheat	Superheat not properly adjusted	Check adjustment of superheat and adjust expansion valve
Insufficient water flow	Chilled water pipes obstructed	Clean pipes and strainer
<b>(H) Discharge pressure too high</b>		
Condense abnormally hot	Presence of uncondensables liquids in the system, or excess of refrigerant	Purge uncondensable fluids and drain off excess refrigerant
Chilled water leaving temperature too high	Overload on cooling system	Reduce load on system. Reduce water flow if necessary
Condenser air output too hot	Reduced air flow. Air intake temperature higher than specified for the unit	Clean and replace air filters. Clean coils. Check operation of the fan motors
<b>(I) Suction pressure too high</b>		
Compressors operates continuously Suction duct abnormally cold. Refrigerant flows back to the compressor	Excess cooling demand on evaporator: (a) Expansion valve too far open (b) Expansion valve locked in an open position	Check system: (a) Check the superheat and check that expansion valve (b) Replace EXV
<b>(J) Suction pressure too low</b>		
Excessive pressure drop through filter drier. Refrigerant does not flow through thermostatic expansion valve	Filter drier clogged. Expansion valve not operating properly	Replace filter drier Replace EXV
Loss of power	Expansion valve obtured	Replace EXV
Superheat too low	Excessive pressure drops through evaporator	Check adjustment of superheat an adjust EXV
<b>(K) Insufficient cooling capacity</b>		
Low pressure drops through evaporator	Low water flow rate	Check water flow rate. Check state of strainer, check for obstruction in chilled water pipes, check pressure switch contact in water

# Notes

Trane - by Trane Technologies (NYSE: TT), a global climate innovator - creates comfortable, energy efficient indoor environments for commercial and residential applications. For more information, please visit [trane.com](http://trane.com) or [tranetechnologies.com](http://tranetechnologies.com).

Trane has a policy of continuous product and product data improvement and reserves the right to change design and specifications without notice. We are committed to using environmentally conscious print practices.

CG-SVX027E-GB October 2022  
Supersedes CG-SVX027D-GB (June 2019)

© 2022 Trane

Confidential and proprietary Trane information