

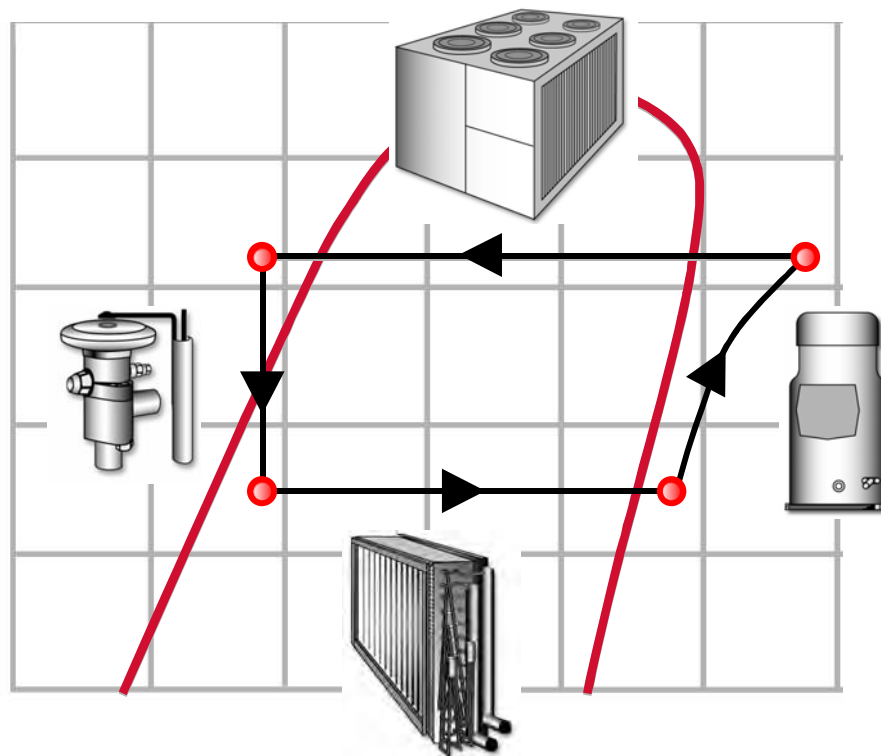

Air Conditioning Clinic

Refrigeration Cycle

One of the Fundamental Series





Refrigeration Cycle

One of the Fundamental Series

A publication of Trane

Preface

Refrigeration Cycle

A Trane Air Conditioning Clinic

Figure 1

Trane believes that it is incumbent on manufacturers to serve the industry by regularly disseminating information gathered through laboratory research, testing programs, and field experience.

The Trane Air Conditioning Clinic series is one means of knowledge sharing. It is intended to acquaint a nontechnical audience with various fundamental aspects of heating, ventilating, and air conditioning.

We have taken special care to make the clinic as uncommercial and straightforward as possible. Illustrations of Trane products only appear in cases where they help convey the message contained in the accompanying text.

This particular clinic introduces the concept of the vapor-compression **refrigeration cycle**. The absorption refrigeration cycle is the subject of a separate clinic.

Contents

period one	Heat and Refrigeration	1
	What is Heat?	2
	Principles of Heat Transfer	4
period two	Refrigerants	9
	Change of Phase	12
	Modern Refrigerants	16
period three	Refrigeration Cycle	17
	Closing the Cycle	18
	Basic Refrigeration System	22
period four	Pressure–Enthalpy Chart	26
period five	Review	35
	Quiz	39
	Answers	42
	Glossary	44



period one

Heat and Refrigeration

notes

Refrigeration Cycle

period one

Heat and Refrigeration

Figure 2

Before discussing the refrigeration system, we need to understand the terms heat and refrigeration.

What is Refrigeration?

Refrigeration is the process of removing heat from one substance and transferring it to another substance.



Figure 3

The term **refrigeration** is commonly associated with something cold. A household refrigerator, for example, keeps food cold. It accomplishes this task by removing heat from the food. Therefore, refrigeration involves the removal of heat. The word cold describes a state of low heat content.

To understand how refrigeration works, we first need to understand what heat is and how it is removed from a substance.

period one
Heat and Refrigeration

notes

What is Heat?

Heat is a form of energy

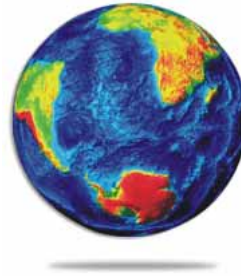

Figure 4

What is Heat?

Heat is a form of energy. Every object on earth contains heat energy in both quantity and intensity.

Quantity and Intensity



Figure 5

Heat intensity is measured by its temperature, commonly in either degrees **Fahrenheit** (°F) or degrees **Celsius** (°C). If all heat were removed from an object, the temperature of the object would decrease to -459.6°F [-273.2°C]. This temperature is referred to as "absolute zero" and is the temperature at which all molecular activity stops.

The quantity of heat contained in an object or substance is not the same as its intensity of heat. For example, the hot sands of the desert contain a large quantity of heat, but a single burning candle has a higher intensity of heat.

period one

Heat and Refrigeration

notes

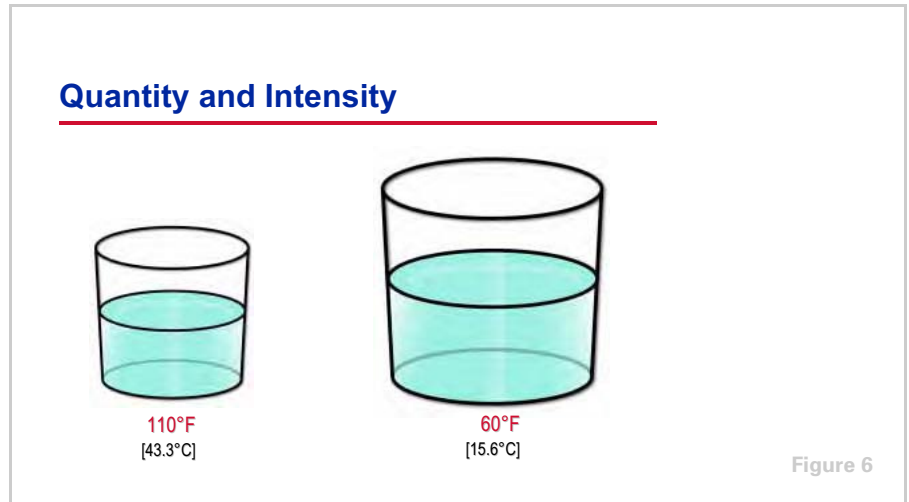

These two different masses of water contain the same quantity of heat, yet the temperature of the water on the left is higher. Why? The water on the left contains more heat per unit of mass than the water on the right. In other words, the heat energy within the water on the left is more concentrated, or intense, resulting in the higher temperature. Note that the temperature of a substance does not reveal the quantity of heat that it contains.

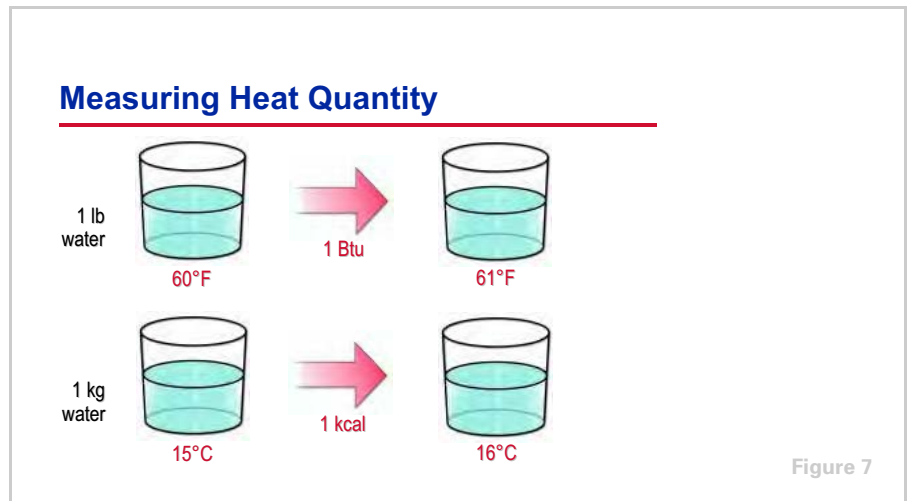

In the English system of units, the quantity of heat is measured in terms of the **British Thermal Unit** (Btu). The Btu is defined as the quantity of heat energy required to raise the temperature of 1 lb of water by 1°F.

Similarly, in the metric system of units, the quantity of heat is measured in terms of the **kilocalorie** (kilogram-calorie or kcal). The kcal is defined as the amount of heat energy required to raise the temperature of 1 kg of water 1°C. Alternatively, in the Systeme International (SI) metric system, heat quantity can be expressed using the unit **kiloJoule** (kJ). One kcal is equal to 4.19 kJ.

period one

Heat and Refrigeration

notes

Principles of Heat Transfer

- ▲ Heat energy cannot be destroyed
- ▲ Heat always flows from a higher temperature substance to a lower temperature substance
- ▲ Heat can be transferred from one substance to another

Figure 8

Principles of Heat Transfer

Air-conditioning and refrigeration systems use the principles of heat transfer to produce cooling and heating. The three principles discussed in this clinic are:

- Heat energy cannot be destroyed; it can only be transferred to another substance
- Heat energy flows from a higher temperature substance to a lower temperature substance
- Heat energy is transferred from one substance to another by one of three basic processes

Heat Energy Cannot Be Destroyed



Figure 9

To produce cooling, heat must be removed from the substance by transferring it to another substance. The first principle to discuss regarding heat transfer is that heat energy cannot be destroyed; it can only be transferred to another

period one

Heat and Refrigeration

notes

substance. This is commonly referred to as the principle of “conservation of energy.”

Ice cubes are typically placed in a beverage to cool it before it is served. As heat is transferred from the beverage to the ice, the temperature of the beverage is lowered. The heat removed from the beverage is not destroyed but instead is absorbed by the ice, changing the ice from a solid to a liquid.

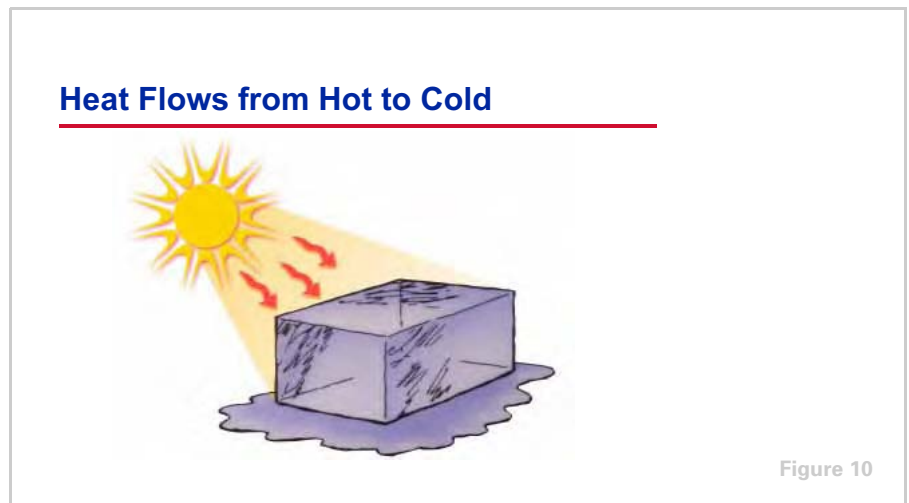

The second principle is that heat naturally flows from a higher temperature substance to a lower temperature substance; in other words, from hot to cold. Heat cannot flow from a cold substance to a hot substance.

Consider the example of the beverage and the ice cubes. As long as the temperature of the beverage is higher than the temperature of the ice cubes, heat will always flow from the beverage to the ice cubes.

period one

Heat and Refrigeration

notes

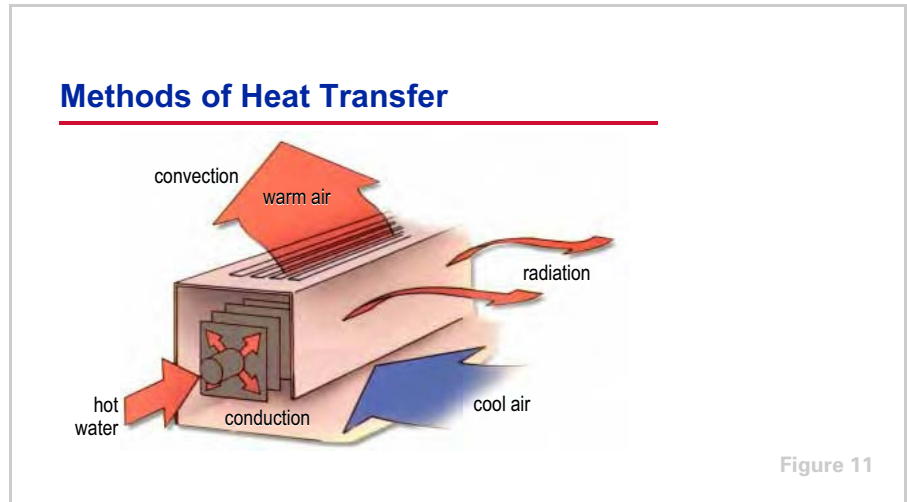

The third principle is that heat is transferred from one substance to another by one of three basic processes: conduction, convection, and radiation. The device shown is a baseboard convector that is commonly used for heating a space. It can be used to demonstrate all three processes of transferring heat.

Hot water flows through a tube inside the convector, warming the inside surface of the tube. Heat is transferred, by conduction, through the tube wall to the slightly cooler fins that are attached to outside surface of the tube.

Conduction is the process of transferring heat through a solid.

The heat is then transferred to the cool air that comes into contact with the fins. As the air is warmed and becomes less dense, it rises, carrying the heat away from the fins and out of the convector. This air movement is known as a convection current. **Convection** is the process of transferring heat as the result of the movement of a fluid. Convection often occurs as the result of the natural movement of air caused by temperature (density) differences.

Additionally, heat is radiated from the warm cabinet of the convector and contacts cooler objects within the space. **Radiation** is the process of transferring heat by means of electromagnetic waves, emitted due to the temperature difference between two objects. An interesting thing about radiated heat is that it does not heat the air between the source and the object it contacts; it only heats the object itself.

period one
Heat and Refrigeration

notes

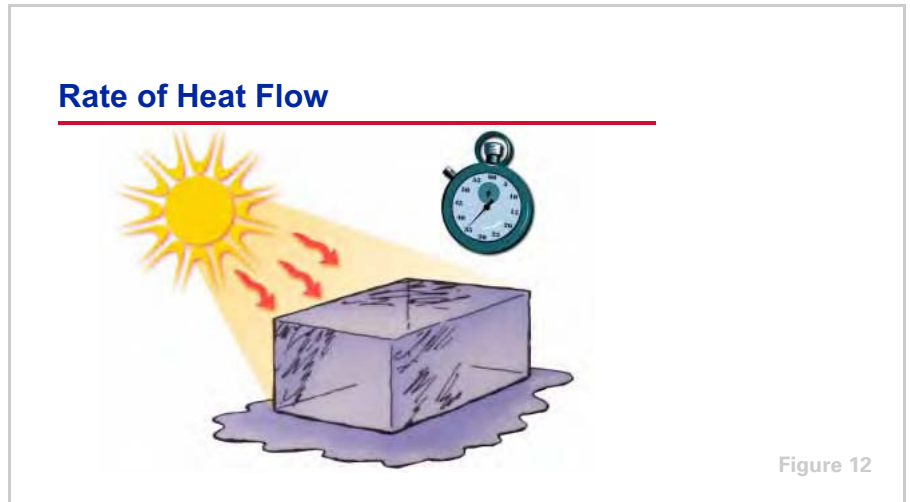

In refrigeration, as in heating, emphasis is placed on the rate of heat transfer, that is, the quantity of heat that flows from one substance to another within a given period of time. This rate of heat flow is commonly expressed in terms of Btu/hr—the quantity of heat, in Btus, that flows from one substance to another over a period of 1 hour.

Similarly, in the SI metric system of units, the rate of heat flow is expressed in terms of kilowatts (kW), which are equivalent to kJ/sec. Kilowatts describe the quantity of heat, in kJ, that flows from one substance to another over a period of 1 second.

period one
Heat and Refrigeration

notes

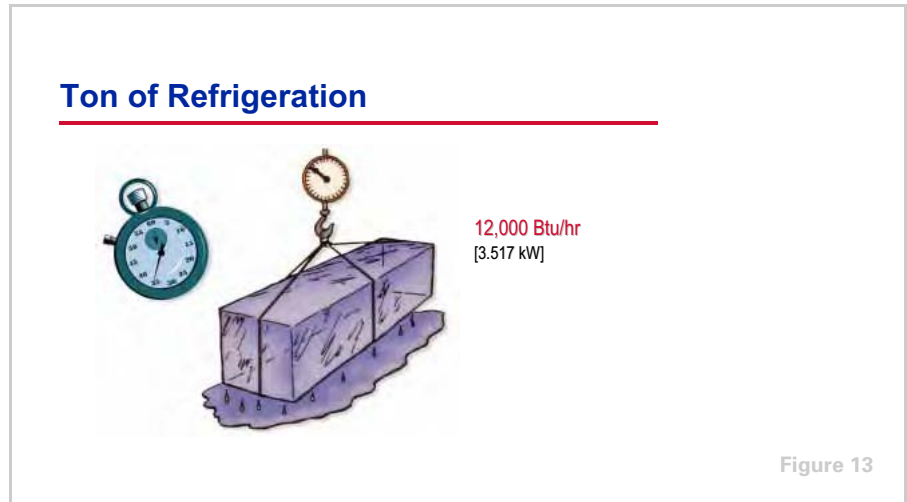

In the English system of units, there is a larger and more convenient measure of the rate of heat flow. It is called a **ton of refrigeration**. One ton of refrigeration produces the same cooling effect as the melting of 2000 lb of ice over a 24-hour period.

When 1 lb of ice melts, it absorbs 144 Btu. Therefore, when 1 ton (2000 lb) of ice melts, it absorbs 288,000 Btu (2000 x 144). Consequently, 1 ton of refrigeration absorbs 288,000 Btu within a 24-hour period or 12,000 Btu/hr (288,000/24).

So, 1 ton of refrigeration is defined as the transfer of heat at the rate of 12,000 Btu/hr [3.517 kW].

period two

Refrigerants

notes

Refrigeration Cycle

period two
Refrigerants

Figure 14

In this period we will discuss refrigerants, the substances used to absorb and transfer heat for the purpose of cooling.

Ice as a Coolant



ice melts at
32°F
[0°C]

Figure 15

Ice can be used to preserve food. Because heat flows from a higher temperature substance to a lower temperature substance, ice can be used in a frozen display case to absorb heat from the relatively warm food, cooling the food. As the ice absorbs heat, it melts and is drained away.

Used in this manner, ice is a coolant. It absorbs heat from the food and transports the heat away from the food.

period two

Refrigerants

notes

Ice as a Coolant



ice melts at
32°F
[0°C]

Figure 16

Pure ice, however, does have an important disadvantage. It absorbs heat and melts at 32°F [0°C]. Ice cream, for example, melts at a temperature lower than 32°F [0°C]. In the same frozen display case, ice cannot keep the ice cream frozen because ice melts at a higher temperature than ice cream.

Dry Ice as a Coolant



dry ice
evaporates at
-109.4°F
[-78.6°C]

Figure 17

There is another type of ice known as dry ice, which is solid (frozen) carbon dioxide (CO₂). It evaporates directly from a solid phase to a vapor phase at -109.4°F [-78.6°C]. Used in the same frozen display case, dry ice would keep the ice cream frozen because it evaporates at a lower temperature than the temperature at which ice cream melts, but would result in an unnecessarily low temperature.

Additionally, both pure ice and dry ice would be consumed in the cooling process, either melting away as a liquid or evaporating into a vapor. It would have to be continually replaced.

period two

Refrigerants

notes

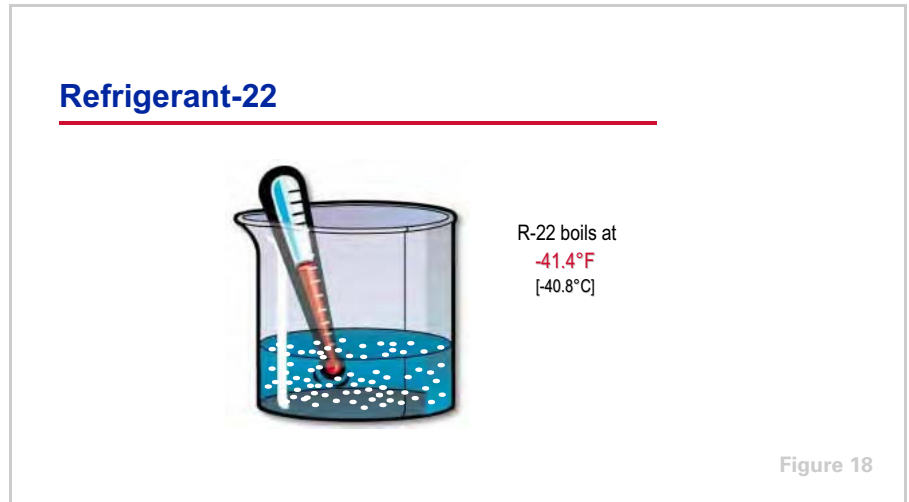

Finally, Refrigerant-22 (R-22) is a chemical used in many refrigeration systems. If, hypothetically, an open container of liquid R-22 were placed in the frozen display case, when exposed to atmospheric pressure, it would absorb heat and boil violently at -41.4°F [-40.8°C].

This is a hypothetical example because chemical refrigerants have environmental regulations that legally require the refrigeration system to be sealed. Any loss of refrigerant to the atmosphere is closely monitored and, generally speaking, not allowed.

At atmospheric pressure, each of these three substances (pure ice, dry ice, and R-22) absorbs heat and changes phase at its own fixed temperature. Pure ice melts at 32°F [0°C], dry ice evaporates at -109.4°F [-78.6°C], and R-22 boils at -41.4°F [-40.8°C].

Why do we want a substance to change phase while producing refrigeration?

period two

Refrigerants

notes

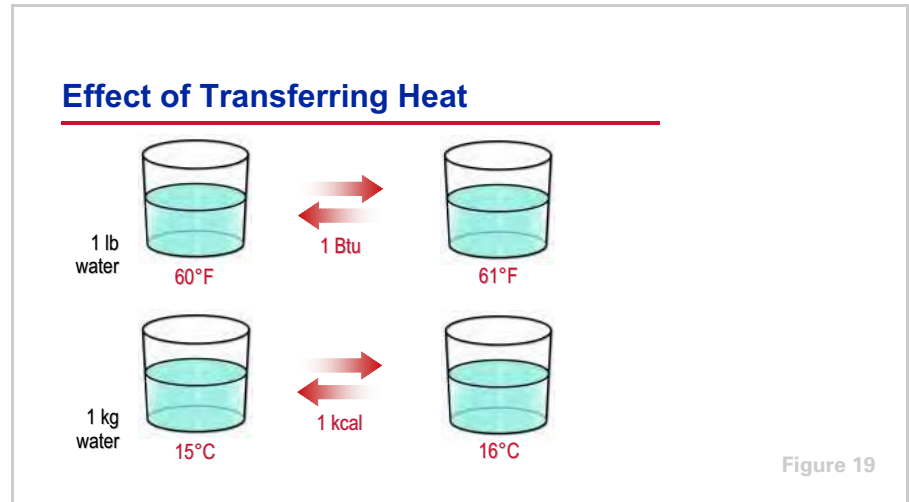

Change of Phase

This question is best answered by examining the effects of heat transfer on water. Consider 1 lb of 60°F water. By adding or subtracting 1 Btu of heat energy, the water temperature is raised or lowered by 1°F.

Similarly, by adding or subtracting 1 kcal (4.2 kJ) of heat energy to a 1 kg container of 15°C water, the water temperature is raised or lowered by 1°C.

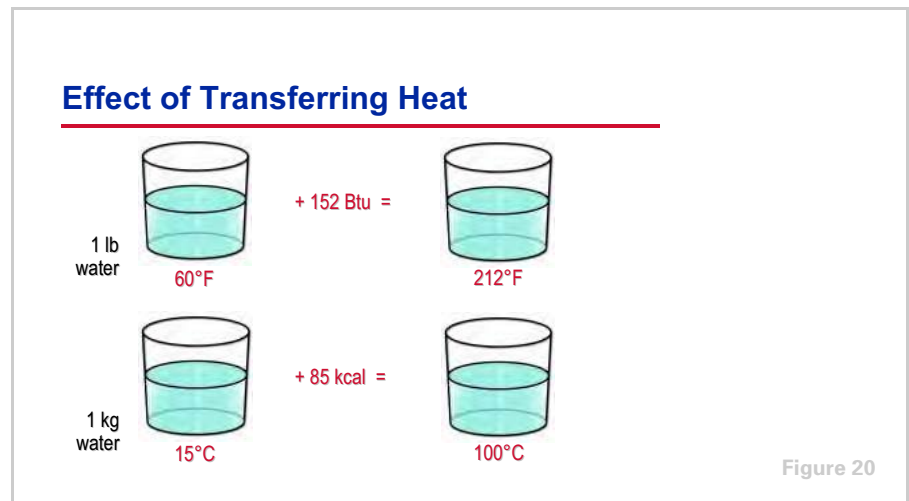

Therefore, adding 152 Btu to 1 lb of 60°F water raises its temperature to 212°F. Although this is the boiling temperature of water at atmospheric pressure, adding 1 more Btu will not cause all of the water to evaporate.

Similarly, adding 85 kcal (356 kJ) to 1 kg of 15°C water raises its temperature to 100°C. Although this is the boiling temperature of water at atmospheric pressure, adding 1 more kcal (4.2 kJ) will not cause all of the water to evaporate.

period two

Refrigerants

notes

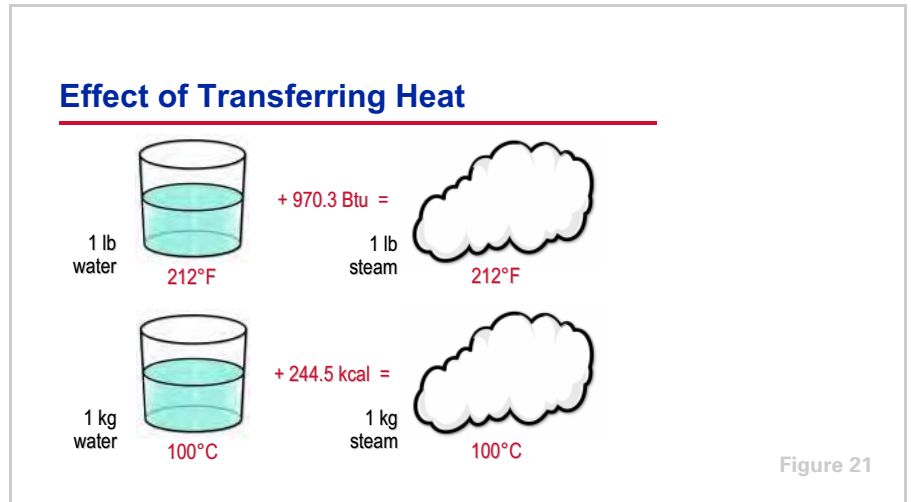

In fact, 970.3 Btu must be added to 1 lb of 212°F water to completely transform it to 1 lb of steam at the same temperature.

Similarly, 244.5.3 kcal (1023 kJ) must be added to 1 kg of 100°C water to completely transform it to 1 kg of steam at the same temperature.

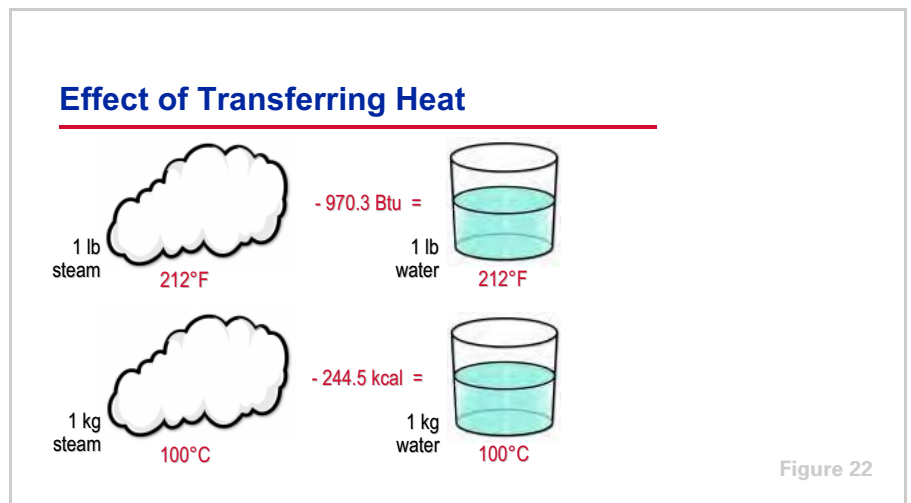

Conversely, when 1 lb of 212°F steam condenses, it gives off 970.3 Btu of heat energy in the process. After the steam condenses completely, the removal of more heat will begin to lower the temperature of the water below 212°F.

Similarly, when 1 kg of 100°C steam condenses, it gives off 244.5 kcal (1023 kJ) of heat energy in the process. After the steam condenses completely, the removal of more heat will begin to lower the temperature of the water below 100°C.

period two
Refrigerants

notes

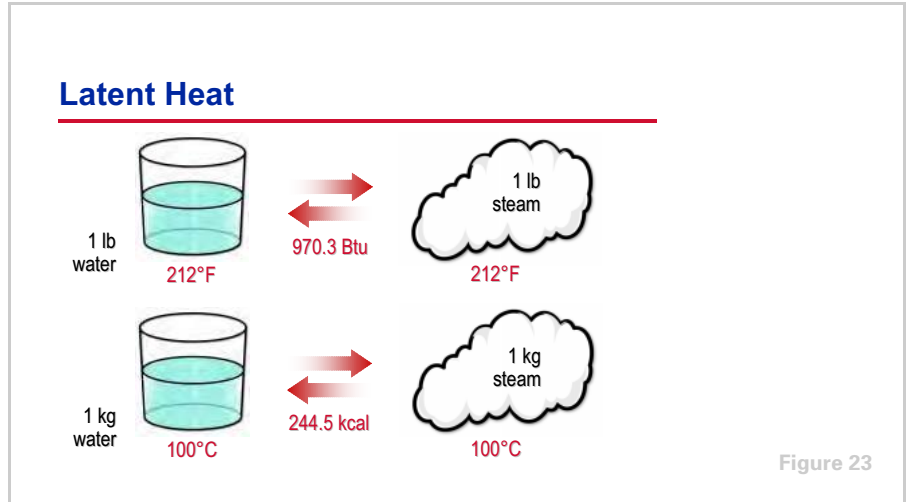

The quantity of heat that must be added to the water in order for it to evaporate cannot be sensed by an ordinary thermometer. This is because both the water and steam remain at the same temperature during this phase change.

This kind of heat is called latent heat, which is dormant or concealed heat energy. **Latent heat** is the energy involved in changing the phase of a substance—from a liquid to a vapor in this example.

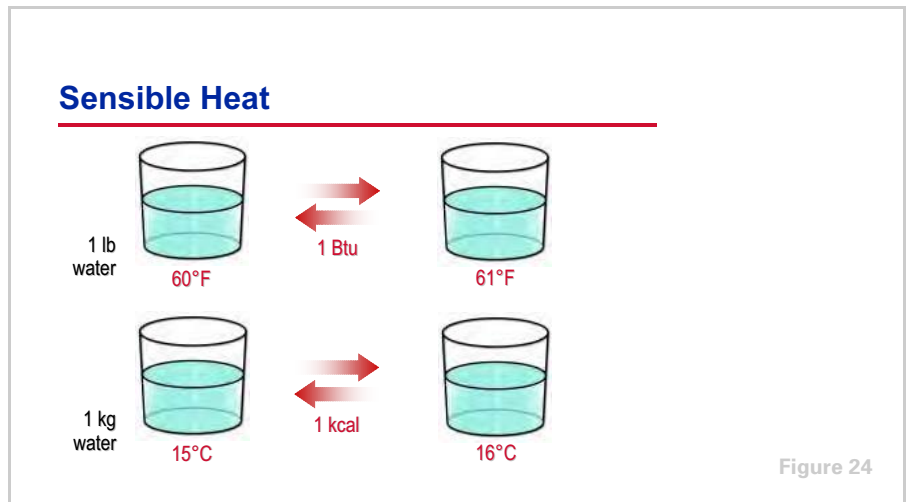

In contrast, **sensible heat** is heat energy that, when added to or removed from a substance, results in a measurable change in temperature.

Refrigerants can absorb a significant amount of heat when they change phase; much more than if they just change temperature. Different substances have different specific temperatures at which these phase changes occur, and different quantities of heat are required for this change to take place. They also

period two

Refrigerants

notes

have different capacities for absorbing heat. This capacity is a property of the substance called specific heat.

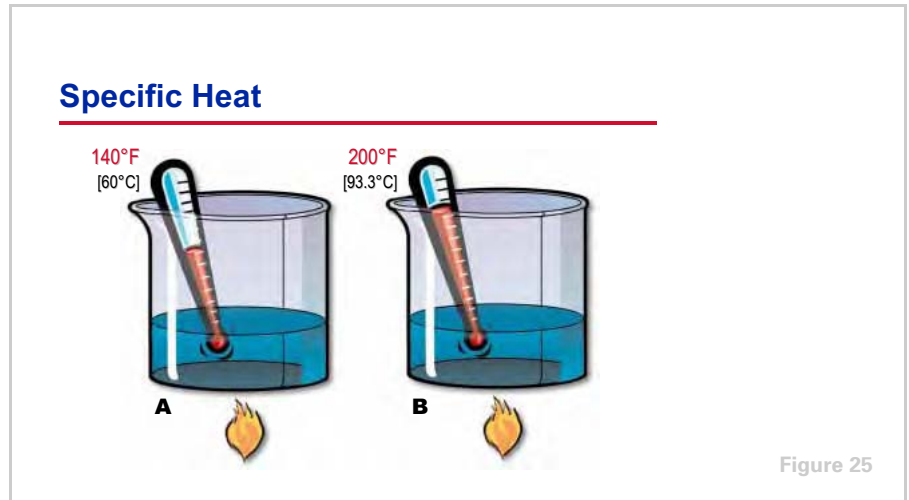

Suppose equal quantities of two different liquids, **A** and **B**, both at room temperature, are heated. The gas burners are lighted and adjusted so that each is burning exactly the same quantity of gas over the same time period, ensuring that each container of liquid receives the same quantity of heat. After a period of time, the thermometer in the container of liquid **A** indicates 140°F [60°C], while the thermometer in the container of liquid **B** indicates 200°F [93.3°C]. Even though equal quantities of the two liquids were supplied with exactly the same *quantity* of heat, why does liquid **B** reach a higher temperature than liquid **A**?

The reason is that liquid **B** has less capacity for absorbing heat than liquid **A**. This capacity for absorbing heat is called **specific heat**. The specific heat of a substance is defined as the quantity of heat, in Btus, required to raise the temperature of 1 lb of that substance 1°F.

Similarly, in metric units, specific heat is defined as the quantity of heat, in kJs, required to raise the temperature of 1 kg of that substance 1°C.

period two

Refrigerants

notes

Modern Refrigerants



Figure 26

Modern Refrigerants

Refrigerants are substances that are used to absorb and transport heat for the purpose of cooling. When selecting a refrigerant to use for a given application, in addition to these heat transfer properties the manufacturer considers efficiency, operating pressures, compatibility with materials, stability, toxicity, flammability, cost, availability, safety, and environmental impact.

The most common refrigerants used in mechanical refrigeration systems today are Refrigerant-123 (or R-123), R-134a, and R-22. Ammonia (R-717) and, under certain operating pressures, even water (R-718) and carbon dioxide (R-744) can be used as refrigerants.

Refrigerant-22 has been the most widely used refrigerant in residential, commercial, and industrial applications since the 1940s. For the purposes of this clinic, it will be used as the refrigerant in the examples.

period three

Refrigeration Cycle

notes

Refrigeration Cycle

period three

Refrigeration Cycle

Figure 27

The frozen display case example used in the last period demonstrates that, at a given pressure, refrigerants absorb heat and change phase at a fixed temperature. It also shows how these refrigerants are “consumed” in the cooling process, either melting into a liquid or evaporating into a vapor.

This period discusses how the refrigerant can be recovered and reused to continue the refrigeration cycle.

Refrigeration System

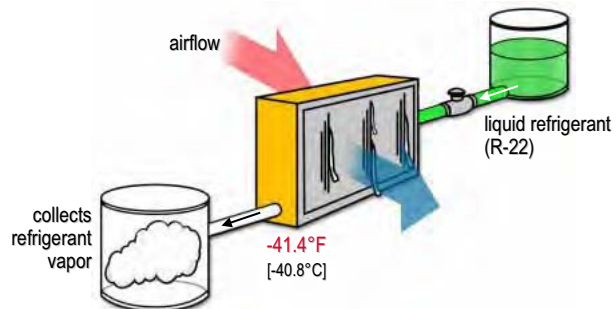

Figure 28

A rudimentary refrigeration system could hypothetically be constructed using a drum of liquid refrigerant at atmospheric pressure, a coil, a collecting drum, and a valve to regulate the flow of refrigerant into the coil. Opening the valve allows the liquid refrigerant to flow into the coil by gravity. As warm air is blown over the surface of the coil, the liquid refrigerant inside the coil will absorb heat from the air, eventually causing the refrigerant to boil while the air is cooled. Adjustment of the valve makes it possible to supply just enough

period three

Refrigeration Cycle

notes

liquid refrigerant to the coil so that all the refrigerant evaporates before it reaches the end of the coil.

One disadvantage of this system is that after the liquid refrigerant passes through the coil and collects in the drum as a vapor, it cannot be reused. The cost and environmental impacts of chemical refrigerants require the refrigeration process to continue without loss of refrigerant.

Additionally, the boiling temperature of R-22 at atmospheric pressure is -41.4°F [-40.8°C]. At this unnecessarily low temperature, the moisture contained in the air passing through the coil freezes on the coil surface, ultimately blocking it completely.

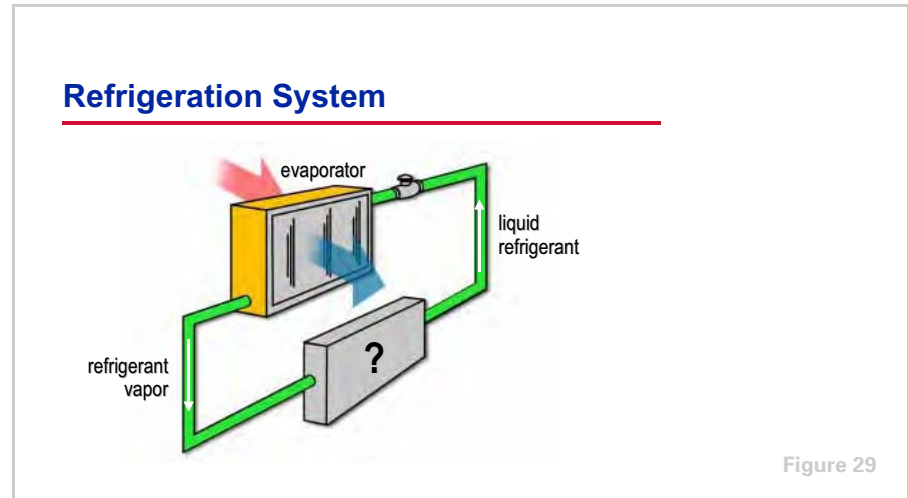

Figure 29

Closing the Cycle

To solve the first problem, a system is needed to collect this used refrigerant and return it to the liquid phase. Then the refrigerant can be passed through the coil again.

This is exactly what happens in a typical mechanical refrigeration system. Liquid refrigerant absorbs heat and evaporates within a device called an evaporator. In this example system, air is cooled when it passes through the evaporator, while the heat is transferred to the refrigerant, causing it to boil and change into a vapor. As discussed in the previous period, a refrigerant can absorb a large amount of heat when it changes phase. Because of the refrigerant changing phase, the system requires far less refrigerant than if the refrigerant was just increasing in temperature.

The refrigerant vapor must then be transformed back into a liquid in order to return to the evaporator and repeat the process.

period three

Refrigeration Cycle

notes

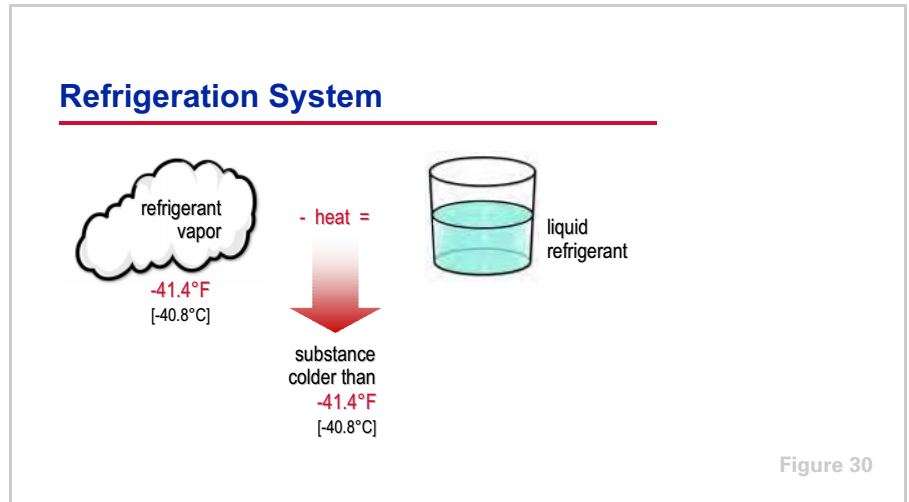

The liquid refrigerant absorbed heat from the air while it was inside the evaporator, and was transformed into a vapor in the process of doing useful cooling. Earlier in this clinic, we demonstrated that if the heat is then removed from this vapor, it will transform (condense) back to its original liquid phase.

Heat flows from a higher temperature substance to a lower temperature substance. In order to remove heat from the refrigerant vapor, it must transfer this heat to a substance that is at a lower temperature. Assume that the refrigerant evaporated at -41.4°F [-40.8°C]. To condense back into liquid, the refrigerant vapor must transfer heat to a substance that has a temperature less than -41.4°F [-40.8°C]. If a substance were readily available at this cooler temperature, however, the refrigerant would not be required in the first place. The cooler substance could accomplish the cooling by itself.

How can heat be removed from this cool refrigerant vapor, to condense it, using a readily-available substance that is already too warm for use as the cooling medium? What if we could change the temperature at which the refrigerant vapor condenses back into liquid?

period three

Refrigeration Cycle

notes

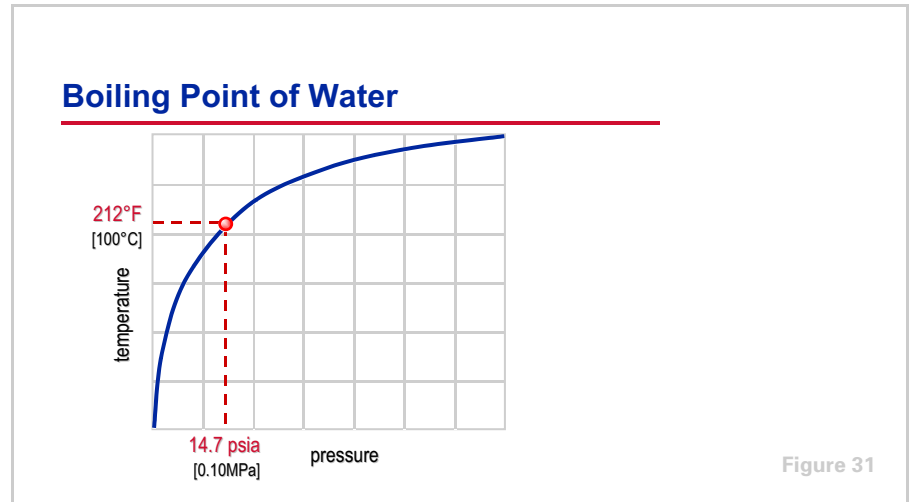

At higher pressures, refrigerant boils and condenses at higher temperatures. This can be explained by examining the properties of water.

At atmospheric pressure (14.7 psia [0.10 MPa]), water boils and evaporates at 212°F [100°C]. When pressure is increased, however, water does not boil until it reaches a much higher temperature. At a higher pressure there is a greater force pushing against the water molecules, keeping them together in a liquid phase.

Recall that, at a given pressure, the temperature at which a liquid will boil into a vapor is the same temperature at which the vapor will condense back into a liquid.

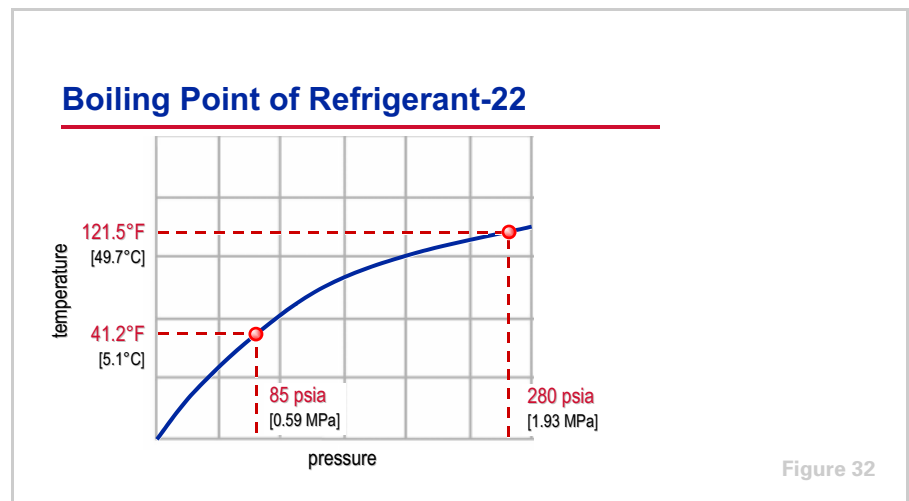

This curve illustrates the pressures and corresponding temperatures at which R-22 boils and condenses. At a pressure of 85 psia [0.59 MPa], the liquid R-22 will boil at 41.2°F [5.1°C]. As an example, assume that a compressor is used to

period three

Refrigeration Cycle

notes

increase the pressure of the resulting refrigerant vapor to 280 psia [1.93 MPa]. This increase in pressure raises the temperature at which the vapor would condense back into liquid to 121.5°F [49.7°C].

In order to condense the refrigerant vapor at this higher temperature, a substance at a temperature less than 121.5°F [49.7°C] is needed. Ambient air or water is generally available at temperatures less than this.

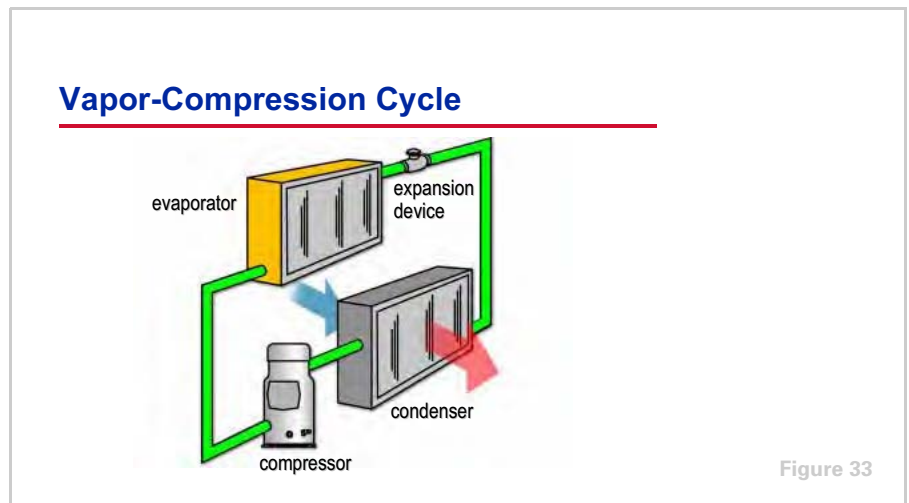

A compressor, condenser, and expansion device form the rest of the system that returns the refrigerant vapor to a low-temperature liquid, which can again be used to produce useful cooling. This cycle is called the **vapor-compression refrigeration cycle**.

In this cycle, a **compressor** is used to pump the low-pressure refrigerant vapor from the evaporator and compress it to a higher pressure.

This hot, high-pressure refrigerant vapor is then discharged into a **condenser**. Because heat flows from a substance at a higher temperature to a substance at a lower temperature, heat is transferred from the hot refrigerant vapor to a cooler condensing media, which, in this example, is ambient air. As heat is removed from the refrigerant, it condenses, returning to the liquid phase. This liquid refrigerant is, however, still at a high temperature.

Finally, an **expansion device** is used to create a large pressure drop that lowers the pressure, and correspondingly the temperature, of the liquid refrigerant. The temperature is lowered to a point where it is again cool enough to absorb heat in the evaporator.

period three

Refrigeration Cycle

notes

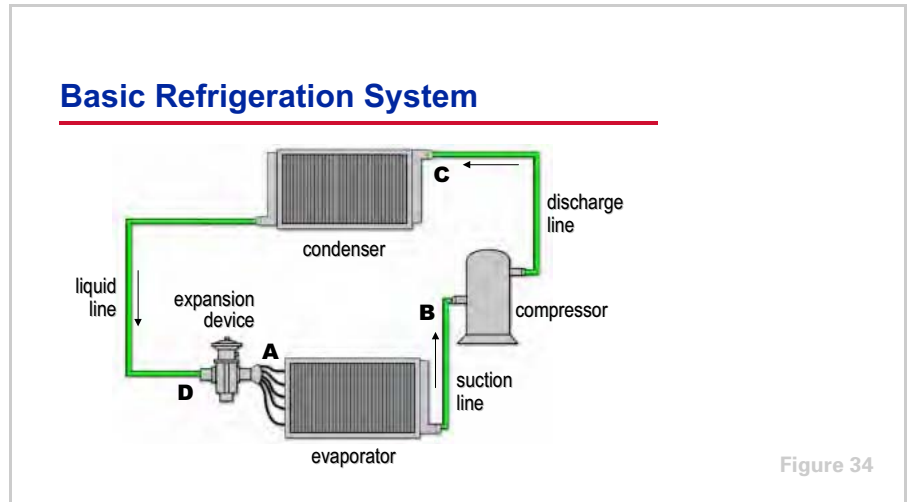

Basic Refrigeration System

This diagram illustrates a basic vapor-compression refrigeration system that contains the described components. First, notice that this is a closed system. The individual components are connected by refrigerant piping. The **suction line** connects the evaporator to the compressor, the **discharge line** connects the compressor to the condenser, and the **liquid line** connects the condenser to the evaporator. The expansion device is located in the liquid line.

Recall that the temperature at which refrigerant evaporates and condenses is related to its pressure. Therefore, regulating the pressures throughout this closed system can control the temperatures at which the refrigerant evaporates and then condenses. These pressures are obtained by selecting system components that will produce the desired balance. For example, select a compressor with a pumping rate that matches the rate at which refrigerant vapor is boiled off in the evaporator. Similarly, select a condenser that will condense this volume of refrigerant vapor at the desired temperature and pressure.

period three

Refrigeration Cycle

notes

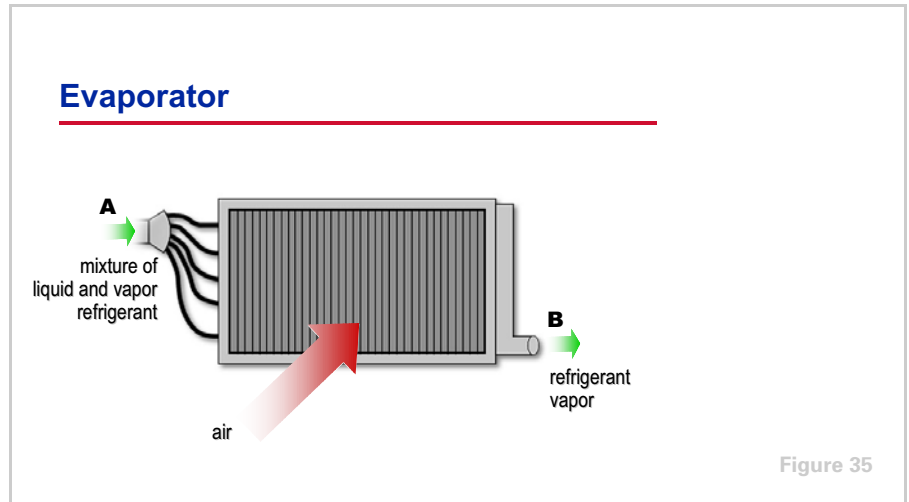

At the inlet to the **evaporator**, the refrigerant exists as a cool, low-pressure mixture of liquid and vapor. In this example, the evaporator is a finned-tube coil used to cool air. Other types of evaporators are used to cool water.

The relatively warm air flows across this finned-tube arrangement and the cold refrigerant flows through the tubes. The refrigerant enters the evaporator (**A**) and absorbs heat from the warmer air, causing the liquid refrigerant to boil. The resulting refrigerant vapor (**B**) is drawn to the compressor.

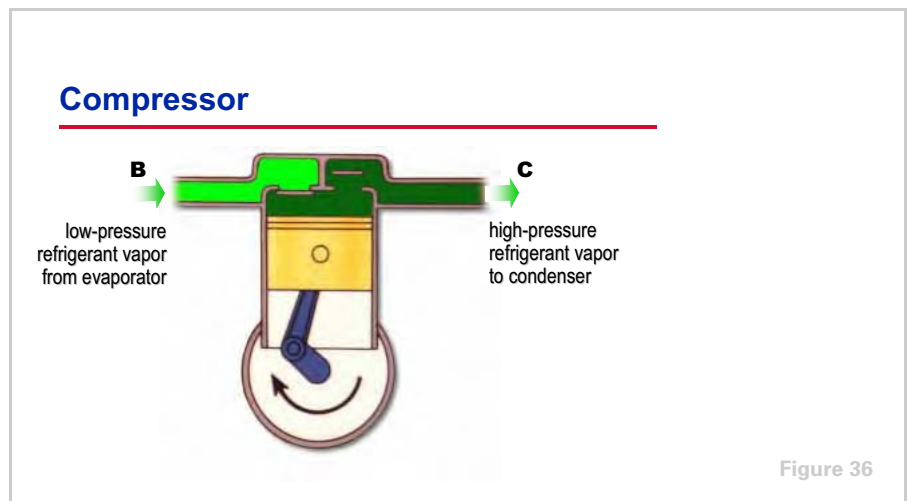

The **compressor** raises the pressure of the refrigerant vapor (**B**) to a pressure and temperature high enough (**C**) so that it can reject heat to another fluid, such as ambient air or water. There are several types of compressors. The type shown in this figure is a reciprocating compressor.

This hot, high-pressure refrigerant vapor then travels to the condenser.

period three

Refrigeration Cycle

notes

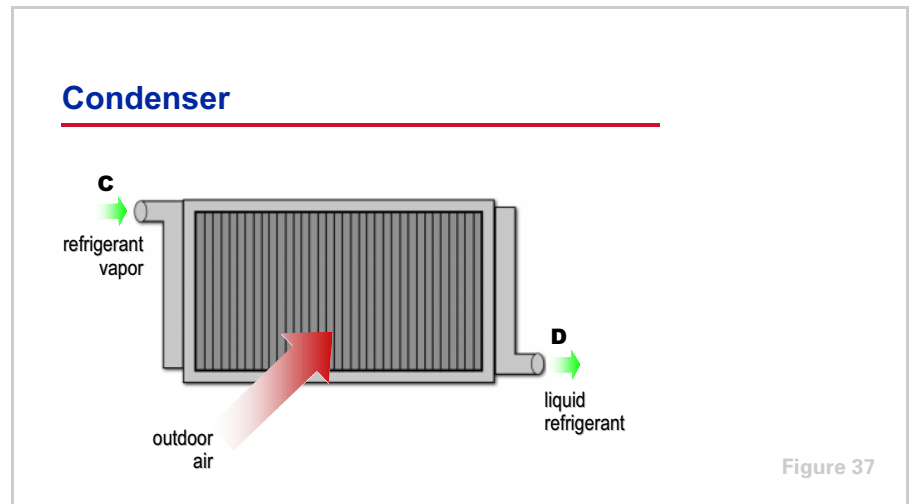

The **condenser** is a heat exchanger used to reject the heat of the refrigerant to another medium. The example shown is an air-cooled condenser that rejects heat to the ambient air. Other types of condensers are used to reject heat to water.

The hot, high-pressure refrigerant vapor (**C**) flows through the tubes of this condenser and rejects heat from the cooler ambient air that passes through the condenser coil. As the heat content of the refrigerant vapor is reduced, it condenses into liquid (**D**).

From the condenser, the high-pressure liquid refrigerant travels to the expansion device.

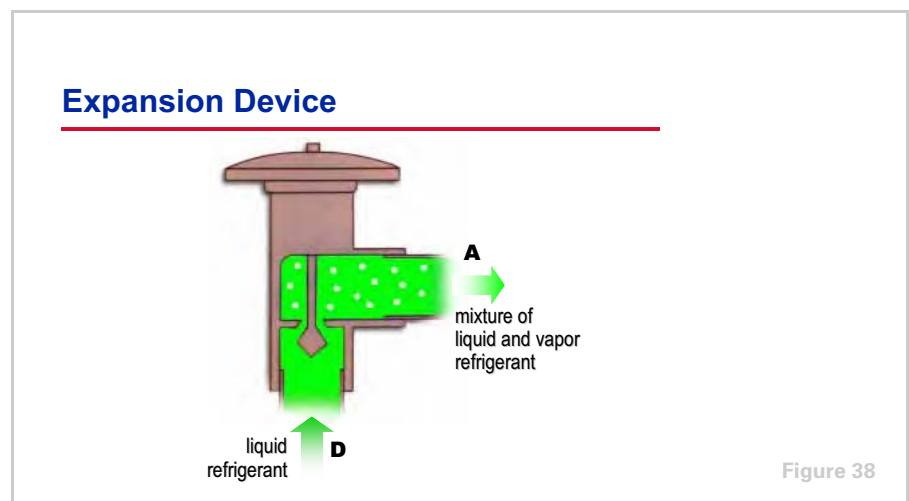

The primary purpose of the **expansion device** is to drop the pressure of the liquid refrigerant to equal the pressure in the evaporator. Several types of expansion devices can be used. The device shown is an expansion valve.

period three

Refrigeration Cycle

notes

The high-pressure liquid refrigerant (**D**) flows through the expansion device, causing a large pressure drop. This pressure drop reduces the refrigerant pressure, and, therefore, its temperature, to that of the evaporator. At the lower pressure, the temperature of the refrigerant is higher than its boiling point. This causes a small portion of the liquid to boil, or flash. Because heat is required to boil this small portion of refrigerant, the boiling refrigerant absorbs heat from the remaining liquid refrigerant, cooling it to the desired evaporator temperature.

The cool mixture of liquid and vapor refrigerant then enters the evaporator (**A**) to repeat the cycle.

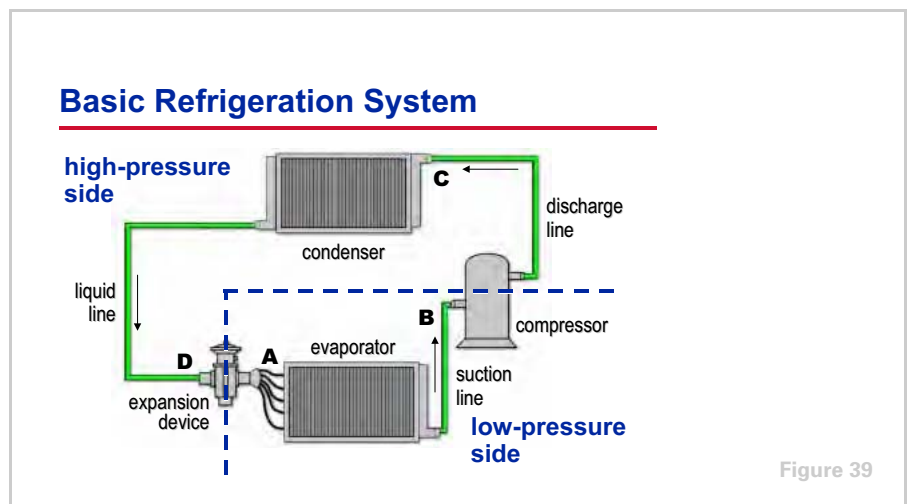

Placing each component in its proper sequence within the system, the compressor and expansion device maintain a pressure difference between the high-pressure side of the system (condenser) and the low-pressure side of the system (evaporator).

This pressure difference allows two things to happen simultaneously. The evaporator can be at a pressure and temperature low enough to absorb heat from the air or water to be cooled, and the condenser can be at a temperature high enough to permit heat rejection to ambient air or water that is at normally available temperatures.

These major components are discussed in further detail in the "Refrigeration Compressors" and "Refrigeration System Components" clinics.

period four

Pressure–Enthalpy Chart

notes

Refrigeration Cycle

period four

Pressure–Enthalpy Chart

Figure 40

During this period we will again analyze the basic vapor-compression refrigeration cycle. However, this time we will use a graphic tool called the pressure–enthalpy chart.

Pressure–Enthalpy (P–h) Chart

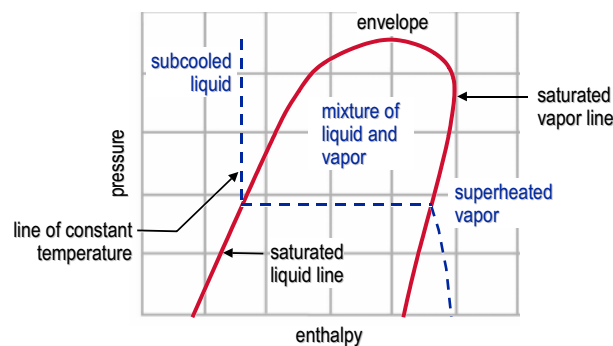

Figure 41

The **pressure–enthalpy (P–h) chart** plots the properties of a refrigerant—refrigerant pressure on the vertical axis and enthalpy on the horizontal axis. **Enthalpy** is a measure of heat quantity, both sensible and latent, per pound [kg] of refrigerant. It is typically expressed in terms of Btu/lb [kJ/kg].

The right-hand side of the chart indicates the conditions at which the refrigerant will be in the vapor phase. The left-hand side of the chart indicates the conditions at which the refrigerant will be in the liquid phase. In the middle of the chart is an envelope (curve). The left-hand boundary of the envelope indicates the saturated liquid condition. The right-hand boundary indicates the saturated vapor condition. If the enthalpy of the refrigerant lies inside the

period four

Pressure–Enthalpy Chart

notes

envelope, the refrigerant exists as a mixture of liquid and vapor. If the enthalpy of the refrigerant lies to the right of the envelope, the vapor is **superheated**. Similarly, if the enthalpy of the refrigerant lies to the left of the envelope, the liquid is **subcooled**.

Lines of constant temperature cross the P–h chart as shown.

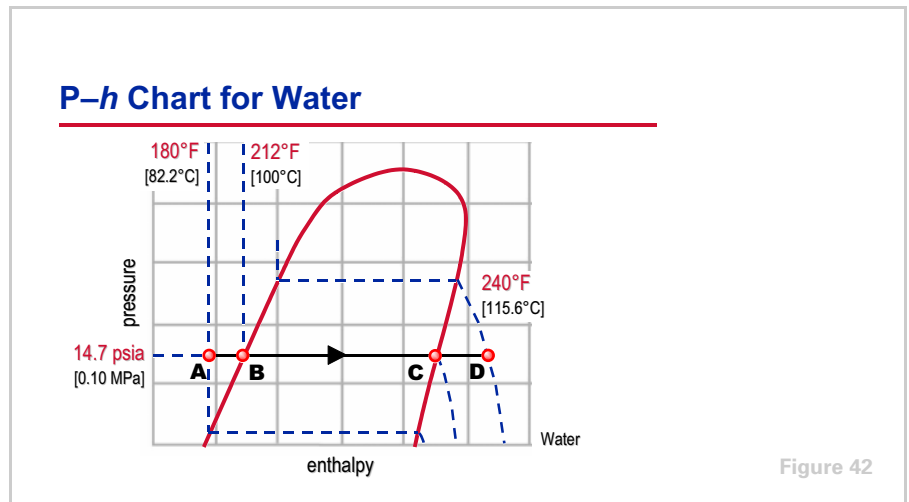

To further demonstrate the use of the P–h chart, let us look at the process of heating and boiling water, at a constant pressure, on a P–h chart for water.

As discussed earlier, at atmospheric pressure (14.7 psia [0.10 MPa]) water boils at 212°F [100°C]. At **A**, the water temperature is 180°F [82.2°C]. As we add heat to the water, the temperature and enthalpy of the water increases as they move toward **B**. When the water reaches its saturated condition (**B**), at 212°F [100°C], it starts to boil and transform into vapor. As more heat is added to the water, it continues to boil while the temperature remains constant. A greater percentage of the water is transforming into vapor as it moves toward **C**.

When the water reaches **C** on the saturation vapor line, it has completely transformed into vapor. Now, as more heat is added to the vapor, its temperature begins to increase again toward **D**, 240°F [115.6°C].

period four

Pressure–Enthalpy Chart

notes

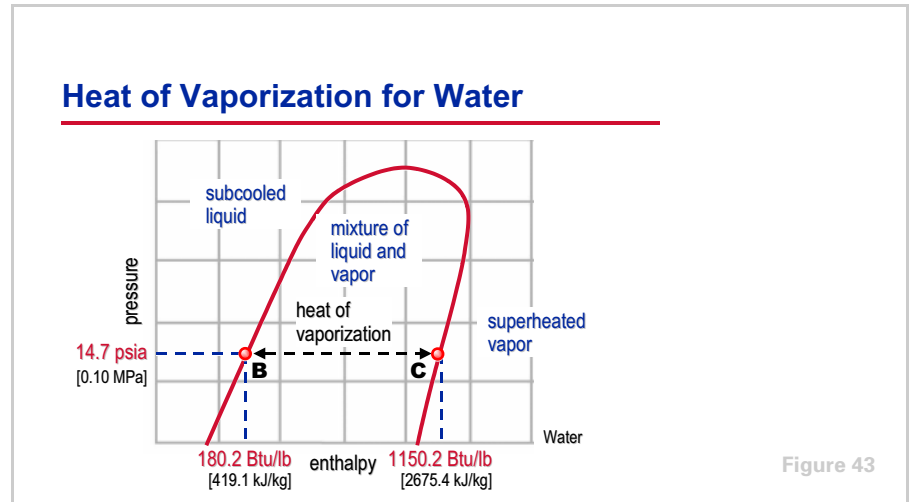

The distance between the edges of the envelope indicates the quantity of heat required to transform saturated liquid into saturated vapor at a given pressure. This is called the **heat of vaporization**.

For example, **B** represents the enthalpy of saturated liquid water at 14.7 psia [0.10 MPa] and **C** represents the enthalpy of saturated water vapor at the same pressure. The difference in enthalpy between **B** and **C**—970 Btu/lb [2256.3 kJ/kg]—is the heat of vaporization for water at this pressure.

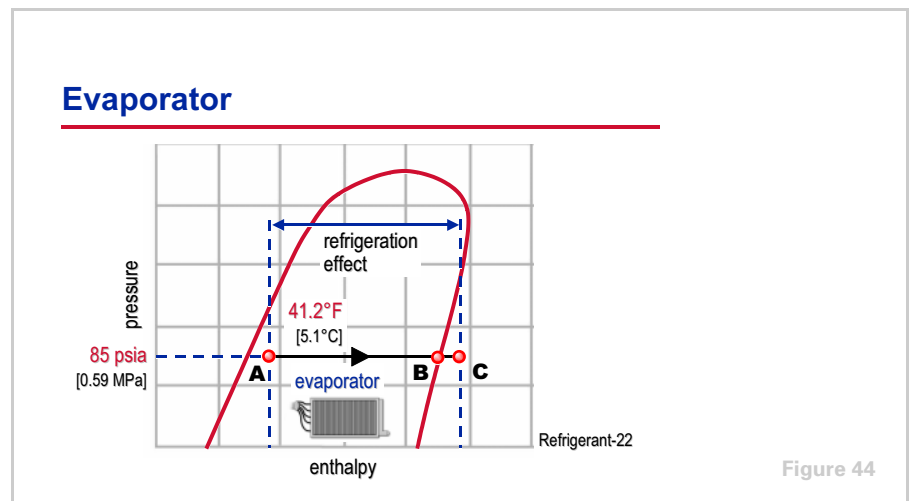

The P - h chart can be used to analyze the vapor-compression refrigeration cycle and determine the conditions of the refrigerant at any point in the cycle. The chart in this example is for R-22.

Because the refrigeration cycle is a continuous process, defining the cycle can start at any point. This example begins in the lower left-hand portion of the P - h chart, where the refrigerant enters the evaporator.

period four

Pressure–Enthalpy Chart

notes

At the inlet to the evaporator, the refrigerant is at a pressure of 85 psia [0.59 MPa] and a temperature of 41.2°F [5.1°C], and is a mixture of liquid and vapor (mostly liquid). This cool, low-pressure refrigerant enters the evaporator (**A**) where it absorbs heat from the relatively warm air that is being cooled. This transfer of heat boils the liquid refrigerant inside the evaporator and superheated refrigerant vapor is drawn to the compressor (**C**).

The change in enthalpy from **A** to **C** that occurs inside the evaporator is called the **refrigeration effect**. This is the amount of heat that each pound [kg] of liquid refrigerant will absorb when it evaporates.

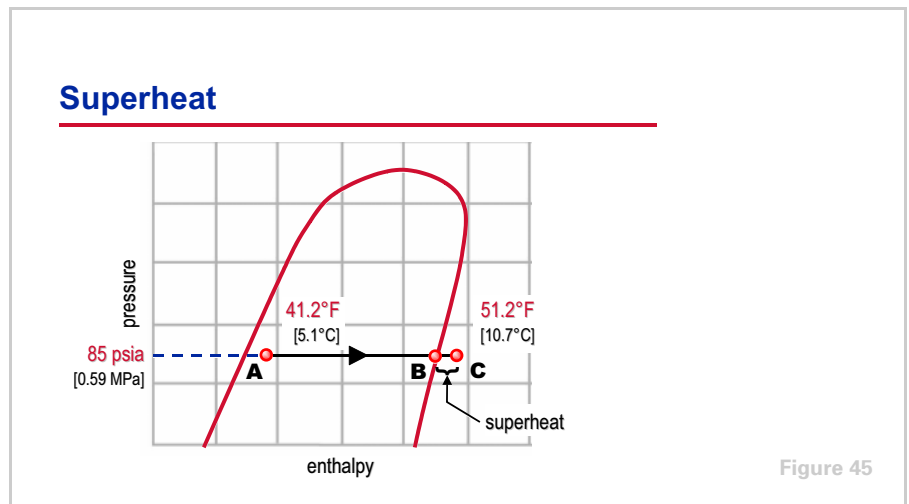

Compressors are designed to compress vapor. Liquid refrigerant can cause damage if drawn into the compressor. In some refrigeration systems additional heat is added to the saturated vapor (**B**) in the evaporator to ensure that no liquid is present at the compressor inlet. This additional amount of heat, above saturation, is called **superheat**. This superheated vapor (**C**) is generally 8°F to 12°F [4.4°C to 6.7°C] above the saturated vapor condition when it enters the compressor. In this example, the refrigerant vapor is superheated 10°F [5.6°C], from 41.2°F [5.1°C] to 51.2°F [10.7°C].

period four

Pressure–Enthalpy Chart

notes

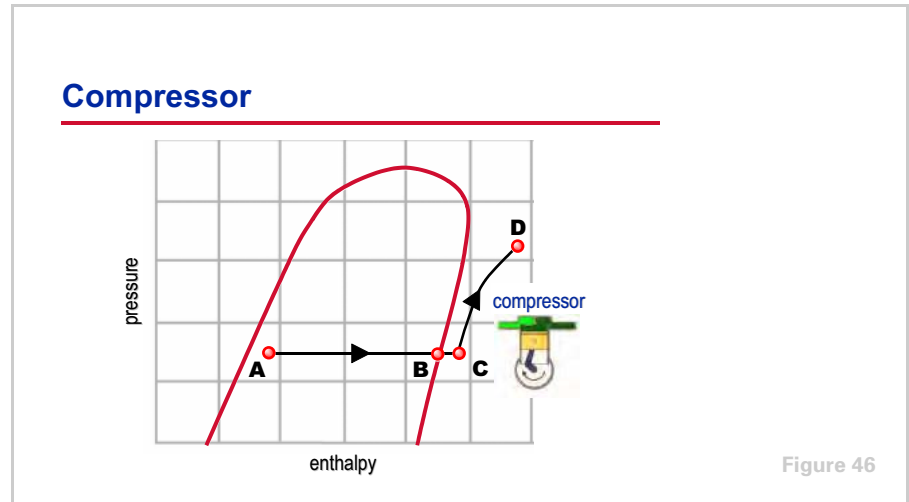

The compressor draws in the superheated refrigerant vapor (**C**) and compresses it to a pressure and temperature (**D**) high enough that it can reject heat to another fluid. As the volume of the refrigerant is reduced by the compressor, its pressure is increased. Additionally, the mechanical energy used by the compressor to accomplish this task is converted to heat energy. This causes the temperature of the refrigerant to also rise as its pressure is increased.

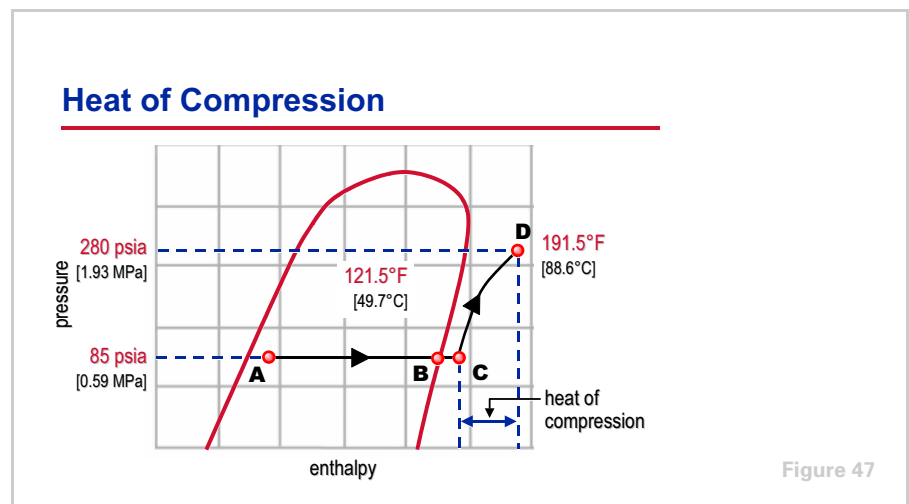

When the refrigerant vapor is discharged from the compressor, its temperature is substantially higher than its saturation temperature (the temperature at which the refrigerant would condense). The increase in enthalpy from **C** to **D** is due to heat added by the compressor, or the **heat of compression**.

In this example, the refrigerant leaves the compressor at 280 psia [1.93 MPa] and 191.5°F [88.6°C]. At this higher pressure, the corresponding saturation

period four

Pressure–Enthalpy Chart

notes

temperature is 121.5°F [49.7°C]. The refrigerant vapor leaving the compressor is therefore 70°F [38.9°C] above its saturation temperature.

This hot, high-pressure refrigerant vapor then travels to the condenser.

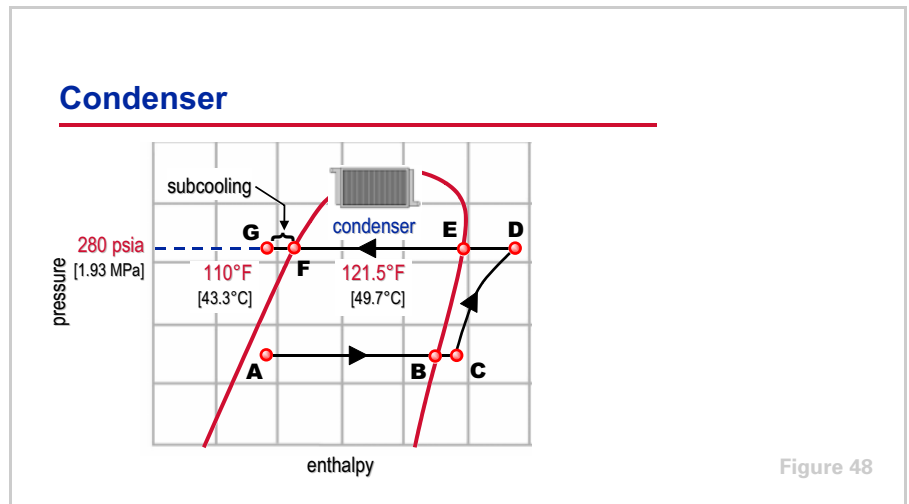

Inside of the condenser, heat is transferred from the hot, high-pressure refrigerant vapor (**D**) to relatively cool ambient air. This reduction in the enthalpy of the refrigerant vapor causes it to desuperheat. It becomes saturated vapor, condenses into saturated liquid, and further subcools before leaving the condenser (**G**) to go to the expansion device.

First, the refrigerant vapor is cooled (the line from **D** to **E**) to its saturation temperature of 121.5°F [49.7°C]. Next, as additional heat is removed by the condenser, the refrigerant vapor condenses to its saturated liquid condition (the line from **E** to **F**). This saturated liquid refrigerant now passes through the area of the condenser called the **subcooler**. Here, the liquid refrigerant is further cooled (the line from **F** to **G**), in this example, to 110°F [43.3°C]. Because the saturation temperature at the condensing pressure is 121.5°F [49.7°C], the refrigerant has been subcooled 11.5°F [6.4°C].

With the temperature of the refrigerant in the condenser this high, air at normal ambient conditions can be used to absorb the heat from the refrigerant. From the condenser, the high-pressure, subcooled liquid refrigerant (**G**) travels to the expansion device.

period four
Pressure–Enthalpy Chart

notes

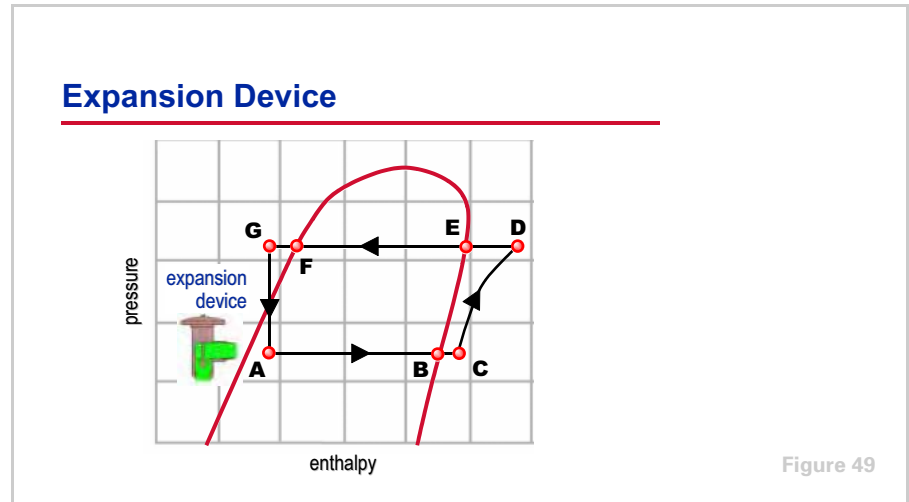

The primary purpose of the expansion device is to drop the pressure of the liquid refrigerant to equal the evaporator pressure. At this lower pressure, the refrigerant is now inside the saturation envelope where it exists as a mixture of liquid and vapor.

The high-pressure liquid refrigerant (**G**) flows through the expansion device, causing a large pressure drop. This pressure drop reduces pressure and temperature of the refrigerant to that of the evaporator (**A**). At the lower pressure, the temperature of the refrigerant is higher than its boiling point. This causes a small portion of the liquid to boil, or flash. Because heat is required to boil this small portion of refrigerant, boiling refrigerant absorbs heat from the remaining liquid refrigerant, cooling it to the evaporator temperature. Notice that there is no change in enthalpy during the expansion process.

The purpose of subcooling the liquid refrigerant in the condenser is to avoid flashing the refrigerant before it reaches the expansion device. If a valve is used as the expansion device, the presence of refrigerant vapor can cause improper operation and premature failure.

period four

Pressure–Enthalpy Chart

notes

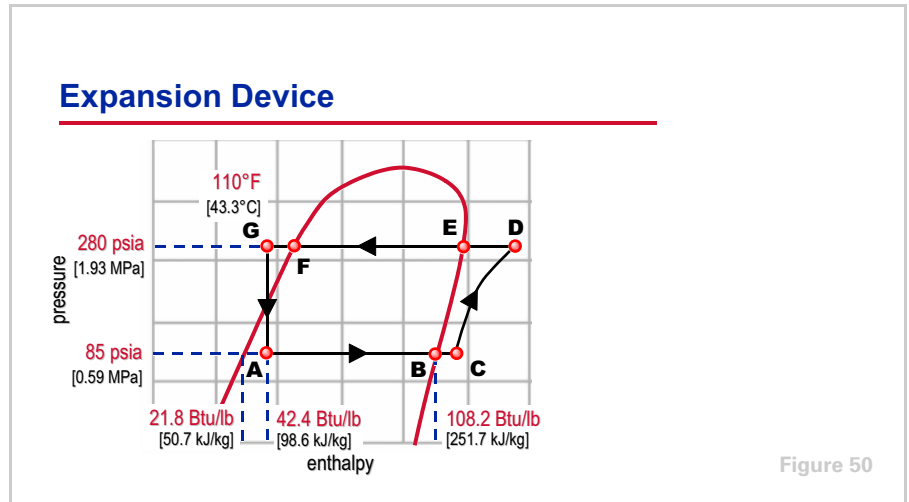

The temperature of the refrigerant entering the expansion device (**G**) is 110°F [43.3°C] and its pressure is 280 psia [1.93 MPa]. (The refrigerant condensed at 121.5°F [49.7°C] and was subcooled to 110°F [43.3°C].) The enthalpy of the refrigerant at this condition is 42.4 Btu/lb [98.6 kJ/kg]. As mentioned previously, there is no change in enthalpy during the expansion process—it is the same at both **G** and **A**.

The refrigerant leaves the expansion device (**A**) at evaporator conditions, 85 psia [0.59 MPa] and 41.2°F [5.1°C]. At this pressure, the enthalpy of saturated liquid is 21.8 Btu/lb [50.7 kJ/kg] and the enthalpy of saturated vapor is 108.2 Btu/lb [251.7 kJ/kg]. Because there is no change of enthalpy during the expansion process, the mixture of liquid and vapor leaving the expansion device must have the same enthalpy as the liquid entering the expansion device. This is true if 76.2% of the refrigerant is liquid and 23.8% of the refrigerant is vapor. This is determined as shown below:

$$\% \text{ of Refrigerant Vapor at } \mathbf{A} = \frac{h_{\mathbf{A}} - h_{\text{saturated liquid}}}{h_{\text{saturated vapor}} - h_{\text{saturated liquid}}}$$

$$\% \text{ of Refrigerant Vapor at } \mathbf{A} = \frac{42.4 \text{ Btu/lb} - 21.8 \text{ Btu/lb}}{108.2 \text{ Btu/lb} - 21.8 \text{ Btu/lb}} = 23.8\%$$

$$\% \text{ of Refrigerant Vapor at } \mathbf{A} = \frac{98.6 \text{ kJ/kg} - 50.7 \text{ kJ/kg}}{251.7 \text{ kJ/kg} - 50.7 \text{ kJ/kg}} = 23.8\%$$

period four
Pressure–Enthalpy Chart

notes

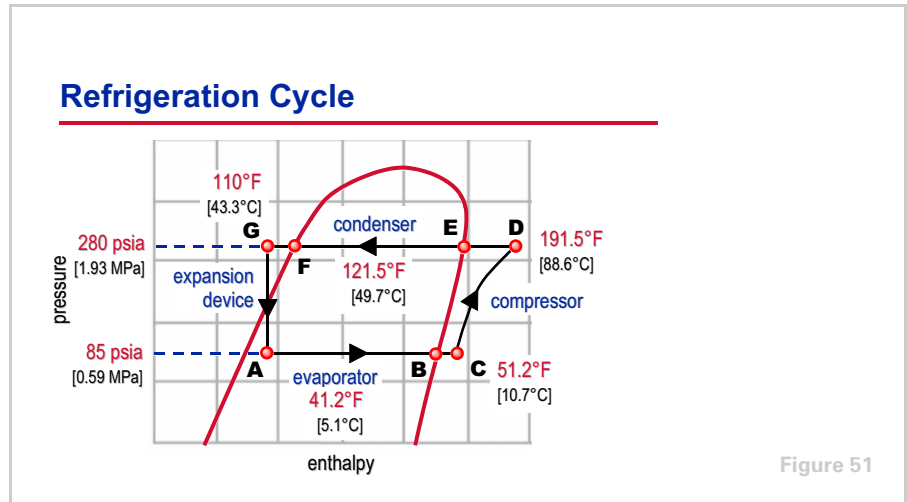

This cool mixture of liquid and vapor refrigerant leaving the expansion device then enters the evaporator (**A**) to repeat the cycle.

The vapor-compression refrigeration cycle has successfully recovered the refrigerant that boiled in the evaporator and converted it back into a cool liquid to be used again.

period five

Review

notes

Refrigeration Cycle

period five
Review

Figure 52

We will now review the main concepts that were covered in this clinic regarding the vapor-compression refrigeration cycle.

Review—Period One

- ▲ Heat is a form of energy
- ▲ Heat can vary in quantity and intensity
- ▲ Heat energy cannot be destroyed
- ▲ Heat can be transferred from one substance to another
- ▲ Heat always flows from a higher temperature substance to a lower temperature substance
- ▲ Refrigeration is a method of removing heat

Figure 53

Period One introduced the concept of heat and how it is transferred from one substance to another.

Recall that heat is a form of energy and can vary in both quantity and intensity (temperature). Heat energy cannot be destroyed, however, it can be transferred to another substance. Heat flows from a higher temperature substance to a lower temperature substance.

Refrigeration is a method of removing heat.

period five

Review

notes

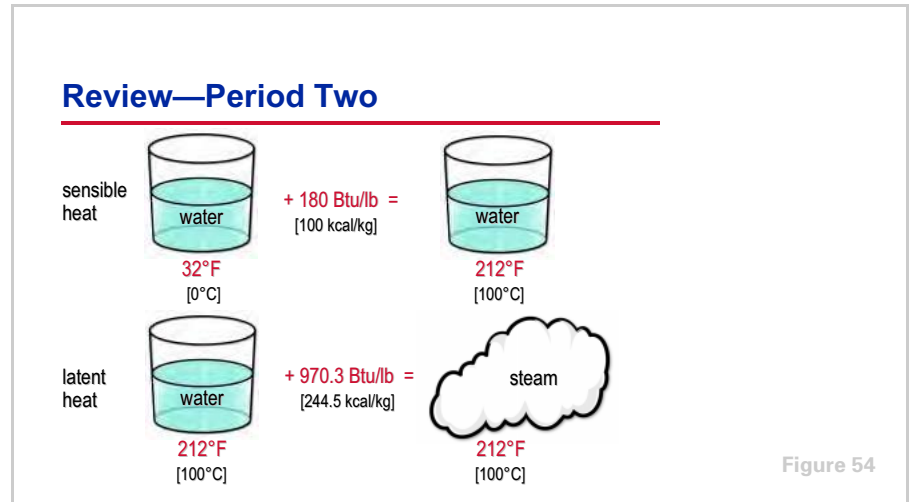

Period Two discussed refrigerants and how they are used in the process of removing and transporting heat.

Remember that refrigerants absorb significant amounts of heat when they change phase (e.g., from a liquid to a vapor). Chemical refrigerants commonly evaporate at low temperatures when exposed to atmospheric pressure. Because of their cost and impact to the environment, however, refrigerants must be recovered in a closed system.

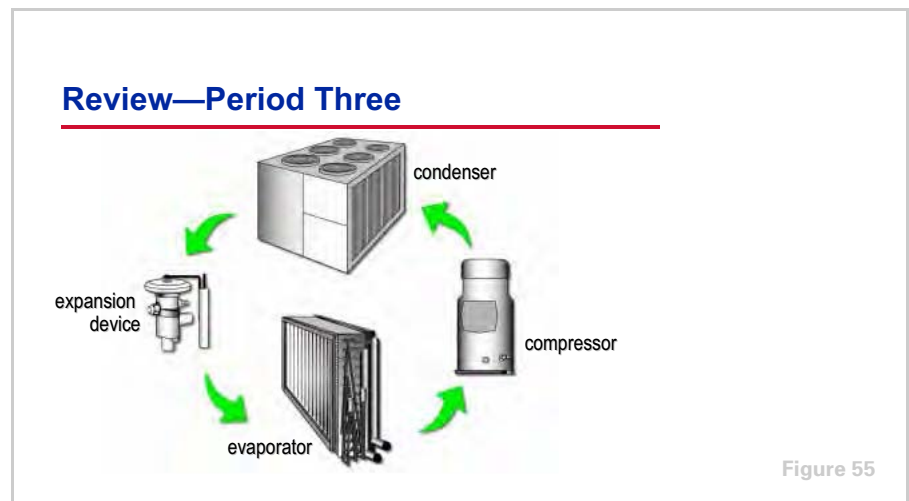

Period Three presented the basic vapor-compression refrigeration cycle, and specifically the use of a compressor, condenser, and expansion device to “recover” the evaporated refrigerant and complete the cycle. The primary components of the vapor-compression refrigeration cycle include the evaporator, compressor, condenser, and expansion device.

period five

Review

notes

Refrigerant enters the evaporator as a cool, low-pressure mixture of liquid and vapor. It absorbs heat—from the relatively warm air or water to be cooled—and boils. The cool, low-pressure vapor is then pumped from the evaporator by the compressor. This increases the pressure and temperature of the refrigerant vapor. The resulting hot, high-pressure refrigerant vapor enters the condenser where it rejects heat to ambient air or water that is at a lower temperature, and condenses into a liquid.

This liquid refrigerant flows from the condenser to the expansion device. The expansion device creates a pressure drop that reduces the pressure of the refrigerant to that of the evaporator. At this low pressure, a small portion of the refrigerant boils off, cooling the remaining liquid refrigerant to the evaporator temperature. The cool mixture of liquid and vapor refrigerant travels to the evaporator where it absorbs heat and boils, repeating the cycle.

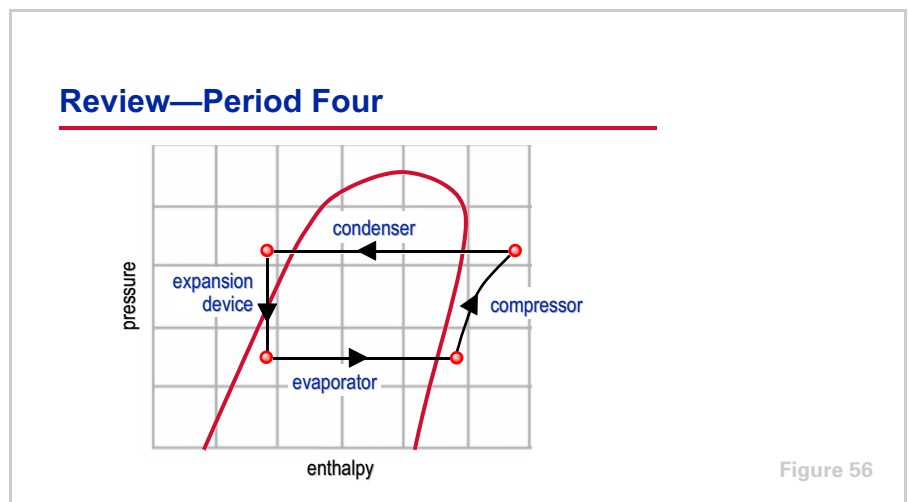

Period Four discussed the use of the pressure–enthalpy (P – h) chart to analyze the refrigeration system.

The pressure–enthalpy chart plots the properties of a refrigerant—pressure versus enthalpy. Enthalpy is a measure of heat quantity per pound [kg] of refrigerant. The chart includes an envelope (curve) that indicates when the refrigerant exists as a subcooled liquid (to the left of the envelope), a mixture of liquid and vapor (inside the envelope), or a superheated vapor (to the right of the envelope).

period five
Review

notes



For more information, refer to the following references:

- *Trane Air Conditioning Manual*
- *Trane Reciprocating Refrigeration Manual*
- *ASHRAE Handbook – Fundamentals*
- *ASHRAE Handbook – Refrigeration*
- *ASHRAE Handbook – Systems and Equipment*

Visit the ASHRAE Bookstore at www.ashrae.org.

For more information on additional educational materials available from Trane, contact your local Trane office (request a copy of the Educational Materials catalog – Trane order number EM-ADV1) or visit our online bookstore at www.trane.com/bookstore/.

Quiz

Questions for Period 1

- 1 Heat intensity is measured in terms of its _____?
- 2 Heat quantity is measured with units of _____?
- 3 Heat always flows from a substance of _____ (higher, lower) temperature to a substance of _____ (higher, lower) temperature.
- 4 What are the three basic processes by which heat is transferred from one substance to another?

Questions for Period 2

- 5 Which process requires more heat energy: raising the temperature of a container of water from 50°F [10°C] to 200°F [93.3°C] or boiling the same quantity of 212°F [100°C] water to 212°F [100°C] steam?
- 6 What type of heat energy, when added to or removed from a substance, results in a measurable change in temperature?
- 7 What type of heat energy, when added to or removed from a substance, results in a change of state of the substance—from a liquid to a vapor or vice-versa?

Questions for Period 3

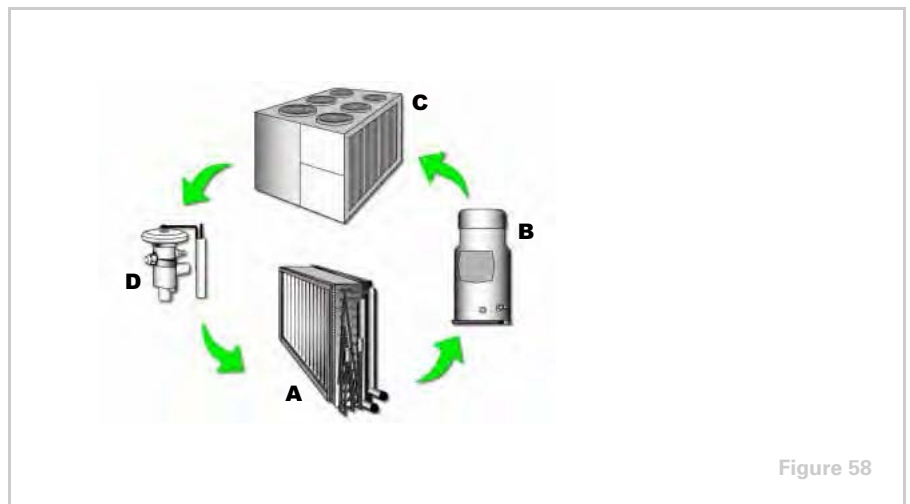

- 8 Identify the four major components of the vapor-compression refrigeration cycle labeled in Figure 58.
- 9 What is the state of the refrigerant when it enters the evaporator?

Quiz

10 What is the state of the refrigerant when it enters the compressor?

11 What is the state of the refrigerant when it enters the expansion device?

Questions for Period 4

12 What is enthalpy?

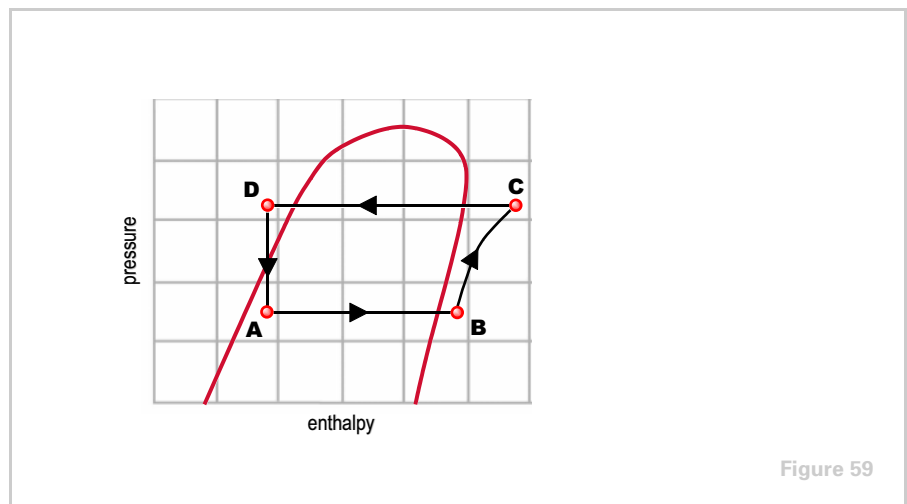

13 Using the pressure–enthalpy chart in Figure 59, identify the components of the vapor-compression refrigeration cycle:

- a** A to B
- b** C to D
- c** B to C
- d** D to A

Quiz

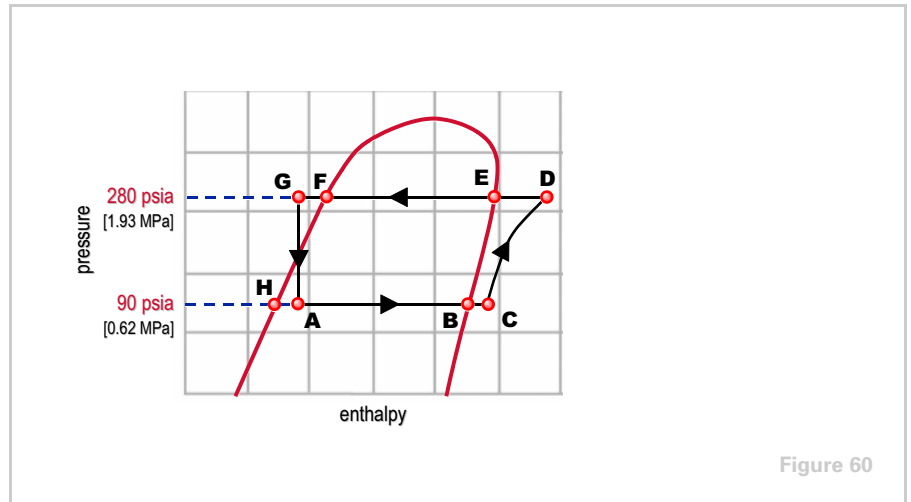

Figure 60

14 Referring to Figure 60 and given the following conditions,

- A** - 44.5°F, 90 psia, 41.6 Btu/lb [6.9°C, 0.62 MPa, 96.8 kJ/kg]
- B** - 44.5°F, 90 psia, 108.5 Btu/lb [6.9°C, 0.62 MPa, 252.4 kJ/kg]
- C** - 54.5°F, 90 psia, 110.3 Btu/lb [12.5°C, 0.62 MPa, 256.6 kJ/kg]
- D** - 190°F, 280 psia, 128.4 Btu/lb [87.8°C, 1.93 MPa, 298.7 kJ/kg]
- E** - 121.5°F, 280 psia, 112.8 Btu/lb [49.7°C, 1.93 MPa, 262.4 kJ/kg]
- F** - 121.5°F, 280 psia, 46.2 Btu/lb [49.7°C, 1.93 MPa, 107.5 kJ/kg]
- G** - 107.5°F, 280 psia, 41.6 Btu/lb [41.9°C, 1.93 MPa, 96.8 kJ/kg]
- H** - 44.5°F, 90 psia, 22.7 Btu/lb [6.9°C, 0.62 MPa, 52.8 kJ/kg]

- a** How much superheat is in this system?
- b** How much subcooling is in this system?
- c** What is the refrigeration effect of this system?
- d** At the inlet to the evaporator, what percentage of the refrigerant exists as a vapor?

Answers

- 1** Temperature or degrees Fahrenheit [degrees Celsius]
- 2** British Thermal Unit (Btu) [kilocalorie (kcal) or kiloJoule (kJ)]
- 3** Higher to lower
- 4** Conduction, convection, and radiation
- 5** Boiling the water requires more energy—970.3 Btu/lb [244.5 kJ/kg]. Raising the temperature of the water from 50°F [10°C] to 200°F [93.3°C] requires 150 Btu/lb [83.3 kJ/kg].
- 6** Sensible heat
- 7** Latent heat
- 8**
 - a** evaporator
 - b** compressor
 - c** condenser
 - d** expansion device
- 9** A mixture of liquid and vapor
- 10** Vapor (possibly superheated vapor)
- 11** Liquid (possibly subcooled liquid)
- 12** The measure of heat quantity, both sensible and latent, per pound [kg] of refrigerant
- 13**
 - a** evaporator
 - b** condenser
 - c** compressor
 - d** expansion device

Answers

- 14 a** 10°F [5.6°C] (temperature rise from **B** to **C**)
b 14°F [7.8°C] (temperature drop from **F** to **G**)
c 68.7 Btu/lb [159.8 kJ/kg] (enthalpy difference between **A** and **C**)
d 22% refrigerant vapor

$$\% \text{ of Refrigerant Vapor at } \mathbf{A} = \frac{\text{Enthalpy at } \mathbf{A} - \text{Enthalpy at } \mathbf{H}}{\text{Enthalpy at } \mathbf{B} - \text{Enthalpy at } \mathbf{H}}$$

$$\% \text{ of Refrigerant Vapor at } \mathbf{A} = \frac{41.6 \text{ Btu/lb} - 22.7 \text{ Btu/lb}}{108.5 \text{ Btu/lb} - 22.7 \text{ Btu/lb}} = 22\%$$

$$\% \text{ of Refrigerant Vapor at } \mathbf{A} = \frac{96.8 \text{ kJ/kg} - 52.8 \text{ kJ/kg}}{252.4 \text{ kJ/kg} - 52.8 \text{ kJ/kg}} = 22\%$$

Glossary

ASHRAE American Society of Heating, Refrigerating and Air-Conditioning Engineers

British Thermal Unit (Btu) A measure of heat quantity, defined as the quantity of heat energy required to change the temperature of 1 lb of water by 1°F.

compressor A mechanical device in the refrigeration system used to increase the pressure and temperature of the refrigerant vapor.

condenser A component of the refrigeration system where refrigerant vapor is converted to liquid as it rejects heat to air, water, or some other fluid.

conduction The process of transferring heat through a solid.

convection The process transferring heat through the movement of a fluid, often through the natural movement of air, caused by temperature (density) differences.

discharge line Pipe that transports refrigerant vapor from the compressor to the condenser in a mechanical refrigeration system.

enthalpy A measure of heat quantity, both sensible and latent, per pound [kg] of refrigerant.

evaporator A component of the refrigeration system where cool, liquid refrigerant absorbs heat from air, water, or some other fluid, causing the refrigerant to boil.

expansion device A component of the refrigeration system used to reduce the pressure and temperature of the refrigerant to the evaporator conditions.

flash The process of liquid refrigerant being vaporized by a sudden reduction of pressure.

heat of compression The amount of heat added to the refrigerant vapor by the compressor during the process of raising the pressure of the refrigerant to condenser conditions.

heat of vaporization The amount of heat required to transform (evaporate) saturated liquid refrigerant to a saturated vapor, at a given pressure.

kilocalorie A measure of heat quantity, defined as the quantity of heat energy required to change the temperature of 1 kg of water by 1°C.

latent heat Heat energy that, when added to or removed from a substance, results in a change of state of the substance—from a liquid to a vapor, from a solid to a liquid, or vice-versa.

liquid line Pipe that transports refrigerant vapor from the condenser to the evaporator in a mechanical refrigeration system.

pressure–enthalpy chart A graphical representation of the properties of a refrigerant, plotting refrigerant pressure versus enthalpy.

Glossary

radiation The process transferring heat by means of electromagnetic waves emitted due to the temperature difference between two objects.

refrigerant A substance used to absorb and transport heat for the purpose of cooling.

refrigeration effect The change in enthalpy that occurs inside the evaporator a refrigeration cycle that indicates the amount of heat that each pound [kg] of liquid refrigerant will absorb when it evaporates.

sensible heat Heat energy that, when added to or removed from a substance, results in a measurable change in temperature.

specific heat The property of a substance describing its capacity for absorbing heat.

subcooling The amount of heat removed from the liquid refrigerant after it has completely condensed within the condenser.

suction line Pipe that transports refrigerant vapor from the evaporator to the compressor in a mechanical refrigeration system.

superheat The amount of heat added to the refrigerant vapor after it has completely vaporized within the evaporator.

ton of refrigeration A measure of the rate of heat flow, defined as a transfer of 12,000 Btu/hr [3.517 kW].



Trane optimizes the performance of homes and buildings around the world. A business of Ingersoll Rand, the leader in creating and sustaining safe, comfortable and energy efficient environments, Trane offers a broad portfolio of advanced controls and HVAC systems, comprehensive building services, and parts. For more information, visit www.Trane.com.

Trane has a policy of continuous product and product data improvement and reserves the right to change design and specifications without notice.