



**TRANE®**

# **Air-Cooled Series R® Helical-rotary Chiller**

---

**Model RTAD 085-100-115-125-145-150-  
165-180  
270 to 630 kW (50 Hz)**

**Integrated Free-Cooling  
Built For the Industrial and  
Commercial Markets**

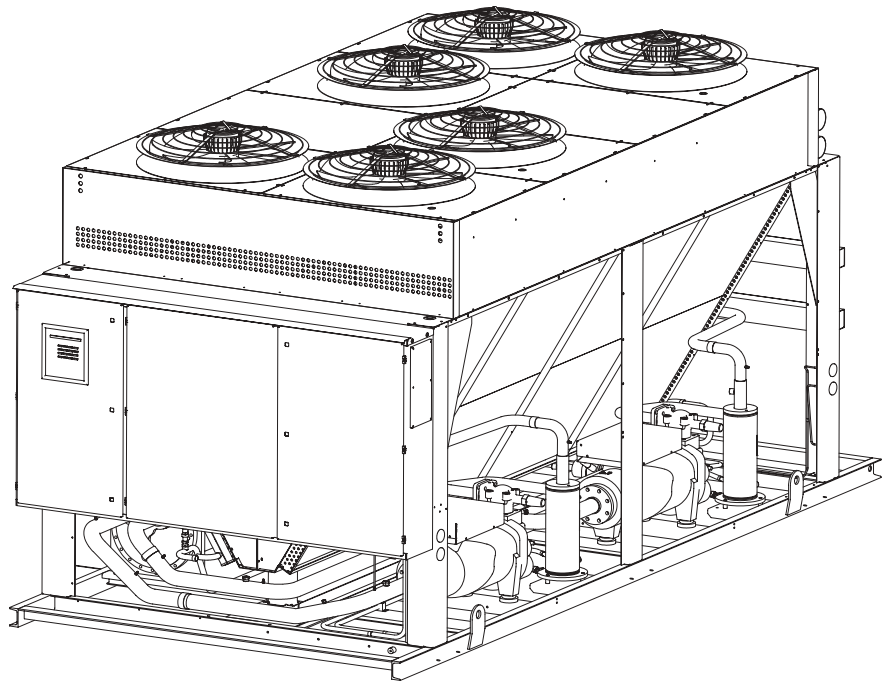

---

**RLC-PRC024-E4**



## Introduction

---

**The Trane model RTAD Free Cooling air-cooled helical-rotary compressor chiller:**

**"A solution providing users energy savings by using the ambient cold."**

Like the standard model RTAD, the Free Cooling version of RTAD utilizes the proven design of the Trane helical- rotary compressors. For further information about RTAD, the product catalogue **RLC-PRC015-E4** is available on request from your local Trane representative.

RTAD Free Cooling offers high reliability coupled with a competitive physical footprint and acoustical performance due to its advanced design, low speed/direct drive compressor and proven Series R<sup>®</sup> performance.

The advantages of the model RTAD Free Cooling are:

- **A small footprint compared to a system where a dry cooler and a chiller are used**
- **One single equipment control**
- **A wide range of capacities**
- **A wide range of applications**

The Series R<sup>®</sup> Model RTAD Free Cooling helical-rotary screw chiller is designed for countries that have a significant yearly number of hours below 0 °C and for applications where cooling is needed year round.



## Contents

---

<b>Introduction</b>	<b>2</b>
<b>Application Considerations</b>	<b>4</b>
<b>Selection Procedure</b>	<b>6</b>
<b>General Data</b>	<b>8</b>
<b>Performance Data</b>	<b>10</b>
<b>Electrical Data</b>	<b>17</b>
<b>Mechanical Specifications</b>	<b>19</b>



## Application Considerations

---

Certain application constraints should be considered when sizing, selecting and installing Trane air-cooled Series R<sup>®</sup> chillers. Unit and system reliability is often dependent upon properly and completely complying with these considerations. When the application varies from the guidelines presented, it should be reviewed with your local Trane sales representative.

### Cooling capacity in Free cooling mode:

For each unit, a cooling capacity is provided at a given condition. If there is a need for more cooling capacity in Free Cooling mode, then some alternatives are available.

- Allow the Leaving Chilled Water Temperature to increase in Winter mode.
- Start the free cooling mode at a lower ambient temperature. The temperature reset point and the free cooling start will be determined by the remaining load inside the building in winter.

**In order to reduce pressure drop and have a more favorable yearly energy balance on the overall installation (chiller and pumps), Trane recommends making the selection at 50% nominal water flow.**

Example:

- Design load: **400 kW**
- Evaporator 7°C / Condenser 12°C, 30% Ethylene Glycol
- Ambient in summer mode: 35°C
- Free Cooling mode temperature changeover: 5°C

The unit which will satisfy those conditions is the **RTAD FC 125 STD**.

# Application Considerations

## Performance in Free Cooling mode:

**Figure 1 - Performance with 50% water flow**

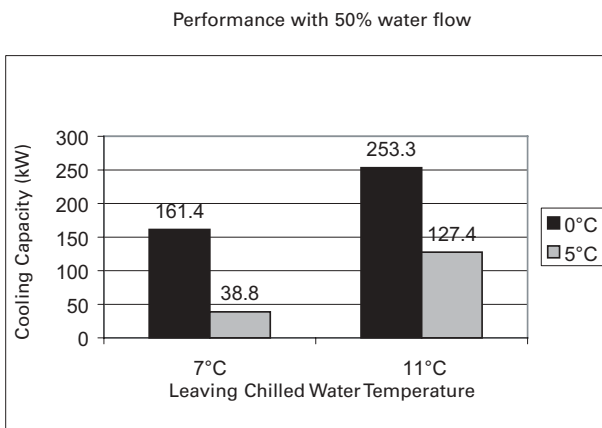

**Figure 2 - Performance with 100% water flow**

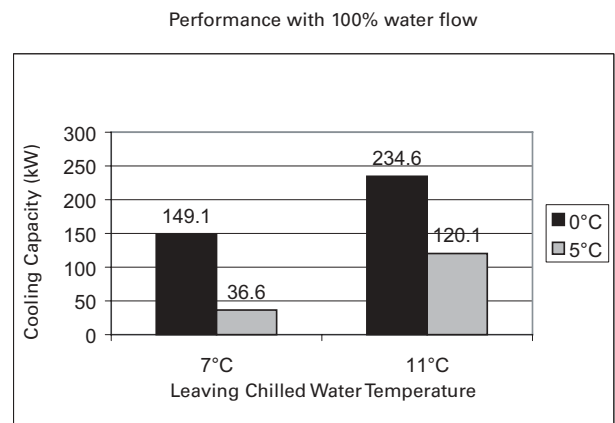

Additional Gain in kW and Gain in Pressure Drop  
Free Cooling mode temperature changeover:  
0°C versus 5°C

Average		Δ Cooling Capacity (kW)	Δ Pressure Drop
Leaving Condenser Water Temperature	7 °C	+ 412%	- 0.2%
	11 °C	+ 197%	- 0.2%

Additional Gain in kW and Gain in Pressure Drop  
Water Flow changeover:  
50% versus 100%

Average		Δ Cooling Capacity (kW)	Δ Pressure Drop
Leaving Condenser Water Temperature	7 °C	+ 7%	- 72%
	11 °C	+ 7%	- 73%



# Selection Procedure

## Selection Procedure SI units:

The chiller capacity tables cover the most frequently encountered leaving liquid temperatures. The tables reflect a 6°C temperature drop through the evaporator. For other temperature drops, apply the appropriate adjustment factors. For chilled brine selections, refer to Table 7 for Ethylene Adjustment Factors.

### Brine composition:

All selection tables are shown with 30% Ethylene Glycol in the cooling loop circuit which is the most convenient percentage in order to protect the unit against freezing.

With Ethylene Glycol:

- freezing point without burst effect = -13°C
- freezing point with burst effect = -50°C

To select a Trane air-cooled RTAD Free Cooling chiller, the following information is required:

1. Design load in kW of refrigeration
2. The remaining cooling load in winter
3. Design chilled water temperature drop
4. Design leaving chilled water temperature
5. Design ambient temperature

Then there are two ways for proceeding the selection:

### A - There is no specification about Free Cooling mode temperature changeover.

If one unit can provide the summer cooling load but not the winter cooling load then the unit with a higher size that can handle the Free Cooling capacity required must be selected.

Example:

For a design load of **520 kW** at 35°C with the condition to have 70% remaining cooling load in winter, which means **364 kW** in winter mode at -5°C in order to produce water at 7°C.

**RTAD FC 150 STD** will match the summer condition load but in free cooling mode it will only give **343.8 kW** at -5°C.

In order to satisfy the winter mode conditions, the unit that will best suit the conditions requested is **RTAD FC 165 STD** which gives **583 kW** in summer mode and **421 kW** in winter mode.

Refer to table below.

	RTAD FC 150	RTAD FC 165	
Summer Mode	527.9 kW	583.5 kW	Match
Winter Mode (50% water flow)	343.8 kW	421 kW	Mismatch



# Selection Procedure

## B - A changeover temperature for Free Cooling is defined.

If there is a temperature setpoint defined for the beginning of the Free Cooling then the selection of the unit has to be done based on this criterion. For the given winter cooling load, the unit that allows Free Cooling to run at the temperature setpoint can be selected using Table 4 or 5.

Evaporator flow rates can be determined by using the following formula:

$$l/s = kW \text{ (Capacity)} \times 0.261 / \text{Temperature Drop } (^{\circ}\text{C})$$

To determine the evaporator pressure drop we use the flow rate (l/s) and the evaporator water pressure drop from Figure 3 or 4.

For selection of chilled brine units or applications where the altitude is significantly greater than sea level or the temperature drop is different than 6°C, the performance adjustment factors from Table 6 and 7 should be applied at this point.

For example:

$$\text{Corrected Capacity} = \text{Capacity (unadjusted)} \times \text{Glycol Capacity Adjustment Factor}$$

$$\text{Corrected Flow Rate} = \text{Flow Rate (unadjusted)} \times \text{Glycol Flow Rate Adjustment Factor}$$

The final unit selection is:

**QTY (1) RTAD FC 180 STD** (Table 3 and 5)

### Summer mode:

- Cooling Capacity = 622.8 kW
- Entering/Leaving Chilled Water Temperatures 13/7°C
- Ambient 35°C
- Chilled Water Flow Rate = 27.09 l/s
- Evaporator Water Pressure Drop = 95.8 kPa
- Power Input = 264.9 kW
- Unit COP = 2.35 kW/kW

### Winter mode:

- Cooling Capacity = 230.1 kW
- Entering/Leaving Chilled Water Temperatures = 9.2/7°C
- Ambient 0°C
- Chilled Water Flow Rate = 27.29 l/s
- Evaporator Water Pressure Drop = 119.6 kPa
- Power Input = 30.5 kW
- Unit COP = 7.54 kW/kW

Contact your local Trane sales representative for selections outside of tabulated conditions.

## Selection Procedure - English units

1 ton = 3.5168 kW

Evaporator flow rate in GPM = 24 x tons / delta T (F)

Delta T (F) = delta T (°C) x 1.8

1 GPM = 0.06309 l/s

1 ft WG = 3 kPa

EER = COP / 0.293

### Note:

In this document the Performance Data given in free cooling mode are for both 100% and 50% nominal water flow (see chapter **Application Considerations** for more details)



# General Data

**Table 1 - General Data RTAD Free Cooling Standard**

Unit Size		085	100	115	125	145	150	165	180
Number of Compressors		2	2	2	2	2	2	2	2
Nominal Size (1)	(Tons)	40/40	50/50	60/60	70/70	85/70	85/85	100/85	100/100
<b>Evaporator</b>									
Evaporator Model		EG120	EG140	EG170	EG200	EG200	EG200	EG250	EG250
Water Storage	(l)	106	270	222	204	204	204	415	415
Minimum Flow	(l/s)	4.1	6	7.3	8.8	8.8	8.8	11.6	11.6
Maximum Flow	l/s)	17.3	20.8	24.8	30.7	30.7	30.7	38	38
<b>Free-Cooler</b>									
Number of Coils		1	1	1	1	1	1	1	1
Fin series	(Fins/ft)	152	152	122	122	152	152	152	152
Number of Rows		4	4	6	6	5	5	5	5
Water Storage (Evap+Free-Cooler)	(l)	265	481	538	520	531	531	806	806
<b>Condenser</b>									
Number of Coils		2	2	2	2	2	2	2	2
Fin series	(Fins/ft)	192	192	192	192	192	192	192	192
Number of Rows		3/3	2/2	3/3	3/3	3/3	3/3	3/3	3/3
<b>Condenser Fans</b>									
Quantity (1)		3/3	3/3	3/3	4/4	5/4	5/5	6/5	6/6
Diameter	(mm)	762	762	762	762	762	762	762	762
Total Air Flow	(m <sup>3</sup> /s)	17.9/13.0	21.6/15.7	20.4/14.7	23.5/17.2	28.4/20.6	29/21.2	34.2/24.8	34.7/25.4
Nominal Speed	(rpm)	935/740	935/740	935/740	935/740	935/740	935/740	935/740	935/740
Motor kW	(kW)	1.7/0.85	1.7/0.85	1.7/0.85	1.7/0.85	1.7/0.85	1.7/0.85	1.7/0.85	1.7/0.85
<b>Min Starting/Oper Ambient(2)</b>	(°C)	-18	-18	-18	-18	-18	-18	-18	-18
<b>General Unit</b>									
Refrigerant		HFC 134a	HFC 134a	HFC 134a	HFC 134a	HFC 134a	HFC 134a	HFC 134a	HFC 134a
No. Of independent Refrigerant Circuits		2	2	2	2	2	2	2	2
% Min. Load (3)		17	17	17	17	17	17	17	17
<b>Weight, Capacities &amp; Dimensions</b>									
Refrigerant Charge (1)	(kg)	24/24	30/32	35/36	36/37	44/48	44/48	61/59	61/63
Oil Charge (1)	(l)	5/5	6/6	8/8	9/9	9/9	9/9	11/10	11/11
Operating Weight (4)	(kg)	3781	4587	5387	5542	6395	6607	7978	8064
Shipping Weight (4)	(kg)	3456	4000	4721	4895	5727	5939	6960	7048
Length	(mm)	3900	4850	4850	4850	5770	5770	6810	6810
Width	(mm)	2420	2420	2420	2420	2420	2420	2460	2460
Height	(mm)	2603	2603	2623	2623	2643	2643	2743	2743
Water Connection Diameter	(mm)	114.3	141.3	141.3	141.3	141.3	141.3	168.3	168.3
Water Connection Type		Victaulic	Victaulic	Victaulic	Victaulic	Victaulic	Victaulic	Victaulic	Victaulic

- (1) Data containing information on two circuits shown as follows: ckt1/ckt2
- (2) Minimum start-up/operation ambient based on a 2.22 m/s wind across the condenser.
- (3) Percent minimum load is for total machine at 10°C ambient and 7°C leaving chilled water temp. Not each individual circuit.
- (4) With aluminum fins





# General Data

**Table 2 - General Data RTAD Free Cooling High Efficiency**

Unit Size		085	100	115	125	145	150
Number of Compressors	Quantity	2	2	2	2	2	2
Nominal Size (1)	(Tons)	40/40	50/50	60/60	70/70	85/70	85/85
<b>Evaporator</b>							
Evaporator Model		EG 140	EG 170	EG 200	EG 200	EG 250	EG 250
Water Storage	(l)	270	222	204	204	415	415
Minimum Flow	(l/s)	6	7.3	8.8	8.8	11.6	11.6
Maximum Flow	l/s)	20.8	24.8	30.7	30.7	38	38
<b>Free-Cooler</b>							
Number of Coils		1	1	1	1	1	1
Fin series	(Fins/ft)	152	122	152	152	152	152
Number of Rows		4	6	5	5	5	5
Water Storage (Evap+Free-Cooler)	(l)	481	538	531	531	806	806
<b>Condenser</b>							
Number of Coils		2	2	2	2	2	2
Fin series	(Fins/ft)	192	192	192	192	192	192
Number of Rows		3/3	3/3	3/3	3/3	3/3	3/3
<b>Condenser Fans</b>							
Quantity (1)		3/3	4/4	4/4	5/5	6/5	6/6
Diameter	(mm)	762	762	762	762	762	762
Total Air Flow	(m <sup>3</sup> /s)	20.8/15.1	23.5/17.2	26/18.9	28.9/21.2	34.1/24.8	34.7/25.4
Nominal Speed	(rpm)	935/740	935/740	935/740	935/740	935/740	935/740
Motor kW	(kW)	1.7/0.85	1.7/0.85	1.7/0.85	1.7/0.85	1.7/0.85	1.7/0.85
<b>Min Starting/Oper Ambient(2)</b>	(°C)	-18	-18	-18	-18	-18	-18
<b>General Unit</b>							
Refrigerant		HFC 134a	HFC 134a	HFC 134a	HFC 134a	HFC 134a	HFC 134a
No. Of independent Refrigerant Circuits		2	2	2	2	2	2
% Min. Load (3)		17	17	17	17	17	17
<b>Weight, Capacities &amp; Dimensions</b>							
Refrigerant Charge (1)	(kg)	32/34	35/36	42/45	42/45	59/61	59/61
Oil Charge (1)	(l)	5/5	6/6	9/9	9/9	10/10	10/10
Operating Weight (4)	(kg)	4725	5198	5995	6094	7929	7983
Shipping Weight (4)	(kg)	4138	4532	5327	5426	6909	6965
Length	(mm)	4850	4850	5770	5770	6810	6810
Width	(mm)	2420	2420	2420	2420	2460	2460
Height	(mm)	2603	2623	2643	2643	2743	2743
Water Connection Diameter	(mm)	141.3	141.3	141.3	141.3	168.3	168.3
Water Connection Type		Victaulic	Victaulic	Victaulic	Victaulic	Victaulic	Victaulic

- (1) Data containing information on two circuits shown as follows: ckt1/ckt2
- (2) Minimum start-up/operation ambient based on a 2.22 m/s wind across the condenser.
- (3) Percent minimum load is for total machine at 10°C ambient and 7°C leaving chilled water temp. Not each individual circuit.
- (4) With aluminum fins



# Performance Data

Table 3 - Standard cooling mode

Unit Size	LCWT (°C) (30%EG)	Ambient air temperature (°C)														
		30					35					40				
		CC (kW)	PI (kW)	COP (kW/KW)	Water flow rate Evap (l/s)	Water Pressure Drop (kPa)	CC (kW)	PI (kW)	COP (kW/KW)	Water flow rate Evap (l/s)	Water Pressure Drop (kPa)	CC (kW)	PI (kW)	COP (kW/KW)	Water flow rate Evap (l/s)	Water Pressure Drop (kPa)
RTAD 085 FC STD	7	290.4	100.3	2.9	12.6	192.1	271.0	107.4	2.5	11.8	167.8	251.1	115.3	2.2	10.9	144.5
	9	308.2	103.7	3.0	13.4	214.4	287.7	110.9	2.6	12.5	187.4	266.7	118.9	2.2	11.6	161.5
	11	326.2	107.2	3.0	14.2	238.4	304.7	114.6	2.7	13.2	208.5	282.6	122.7	2.3	12.3	179.9
RTAD 100 FC STD	7	338.5	118.0	2.9	14.7	94.3	315.6	125.7	2.5	13.7	82.3	292.3	134.3	2.2	12.7	70.8
	9	358.7	122.3	2.9	15.6	104.9	334.6	130.2	2.6	14.6	91.6	310.0	138.9	2.2	13.5	78.9
	11	379.5	126.8	3.0	16.5	116.4	354.2	134.8	2.6	15.4	99.9	328.2	143.7	2.3	14.3	87.6
RTAD 115 FC STD	7	399.2	149.6	2.7	17.4	129.3	371.4	161.2	2.3	16.2	112.3	342.8	174.0	2.0	14.9	96.2
	9	421.7	155.2	2.7	18.3	142.9	392.1	167.0	2.3	17.1	124.1	361.9	180.1	2.0	15.7	106.3
	11	444.5	161.0	2.8	19.3	157.4	413.2	173.1	2.4	18.0	136.6	381.6	186.3	2.0	16.6	116.8
RTAD 125 FC STD	7	467.4	183.8	2.5	20.4	112.2	435.0	197.7	2.2	19.0	97.7	402.3	212.8	1.9	17.5	83.9
	9	493.8	190.5	2.6	21.5	123.9	459.7	204.6	2.2	20.0	107.8	424.8	220.0	1.9	18.5	92.6
	11	520.1	197.5	2.6	22.6	136.2	484.3	211.8	2.3	21.0	118.5	447.7	227.4	2.0	19.4	101.7
RTAD 145 FC STD	7	532.5	192.0	2.8	23.2	144.8	498.3	206.0	2.4	21.7	127.2	463.5	221.4	2.1	20.2	110.5
	9	564.1	199.0	2.8	24.5	160.9	527.9	220.6	2.4	23.0	141.3	491.0	228.8	2.1	21.3	122.7
	11	596.1	206.2	2.9	25.9	178.1	557.8	220.6	2.5	24.2	156.4	518.4	236.4	2.2	22.5	135.7
RTAD 150 FC STD	7	564.8	214.2	2.6	24.6	162.4	527.9	229.6	2.3	23.0	142.4	490.3	246.4	2.0	21.4	123.3
	9	596.8	222.1	2.7	26.0	179.6	557.8	237.7	2.3	24.3	157.4	518.0	254.8	2.0	22.5	136.3
	11	629.2	230.4	2.7	27.3	197.9	588.0	246.2	2.4	25.5	173.4	545.8	263.4	2.1	23.7	150.0
RTAD 165 FC STD	7	621.1	224.3	2.8	27.0	99.2	583.5	240.2	2.4	25.4	87.9	545.1	257.7	2.1	23.7	77.0
	9	658.0	232.6	2.8	28.6	110.3	618.3	248.9	2.5	26.9	97.7	577.1	266.8	2.2	25.1	85.4
	11	695.6	241.4	2.9	30.2	122.1	653.4	258.0	2.5	28.4	108.1	609.8	276.2	2.2	26.5	94.5
RTAD 180 FC STD	7	662.6	247.4	2.7	28.9	112.5	622.8	264.9	2.4	27.1	99.7	581.3	284.2	2.0	25.3	87.3
	9	700.9	256.9	2.7	30.5	124.8	658.7	274.9	2.4	28.6	110.5	614.8	294.6	2.1	26.7	96.6
	11	740.0	266.9	2.8	32.2	137.9	695.3	285.3	2.4	30.2	122.0	648.9	305.5	2.1	28.2	106.6
RTAD 085 FC HE	7	309.5	94.9	3.3	13.5	79.5	289.3	101.3	2.9	12.6	69.7	268.6	108.5	2.5	11.7	60.3
	9	329.0	98.0	3.4	14.3	88.9	307.6	104.5	2.9	13.4	78.0	285.7	111.8	2.6	12.4	67.5
	11	348.9	101.3	3.4	15.2	99.1	326.4	107.9	3.0	14.2	87.0	303.3	115.3	2.6	13.2	75.4
RTAD 100 FC HE	7	370.7	115.2	3.2	16.1	112.0	346.6	122.7	2.8	15.1	98.3	321.9	131.1	2.5	14.0	85.2
	9	393.5	118.8	3.3	17.1	125.0	368.2	126.5	2.9	16.0	109.8	342.3	135.1	2.5	14.9	95.3
	11	417.1	122.6	3.4	18.1	139.1	390.4	130.5	3.0	17.0	122.3	363.3	139.2	2.6	15.8	106.2
RTAD 115 FC HE	7	432.9	145.5	3.0	18.9	96.8	405.5	156.1	2.6	17.7	85.2	377.0	168.0	2.2	16.4	74.1
	9	488.5	155.6	3.1	20.0	108.3	431.2	161.3	2.7	18.8	95.4	401.3	173.4	2.3	17.5	83.0
	11	405.5	156.1	2.6	17.7	85.1	457.5	166.7	2.7	19.9	106.3	425.9	178.9	2.4	18.5	92.5
RTAD 125 FC HE	7	504.3	178.9	2.8	22.0	130.2	472.7	191.9	2.5	20.6	114.8	440.3	206.1	2.1	19.2	100.0
	9	535.6	185.0	2.9	23.3	145.4	502.2	198.1	2.5	21.8	128.2	467.7	212.5	2.2	20.3	111.7
	11	567.6	191.2	3.0	24.7	161.9	532.1	204.6	2.6	23.1	142.7	495.9	219.2	2.3	21.5	124.4
RTAD 145 FC HE	7	545.5	183.7	3.0	23.7	77.1	513.1	196.6	2.6	22.3	68.5	479.7	210.9	2.3	20.9	60.2
	9	579.9	189.9	3.1	25.2	86.3	545.8	203.0	2.7	23.7	76.7	510.7	217.4	2.3	22.2	67.3
	11	615.5	196.3	3.1	26.7	96.2	579.2	209.6	2.8	25.2	85.5	542.0	224.2	2.4	23.5	75.1
RTAD 150 FC HE	7	581.7	204.5	2.8	25.3	87.4	546.9	218.6	2.5	23.8	77.5	511.0	234.2	2.2	22.2	67.9
	9	617.6	211.6	2.9	26.9	97.4	580.3	225.9	2.6	25.2	86.4	542.3	241.7	2.2	23.6	75.7
	11	653.8	219.0	3.0	28.4	108.3	614.8	233.5	2.6	26.7	96.0	574.3	249.5	2.3	25.0	84.1

- Notes :
1. Temperature drop = 6°C
  2. 30% ethylene glycol
  3. Ratings based on sea level altitude and evaporator fouling factor of 0.0176 m<sup>2</sup> K/kW
  4. Consult Trane representative for performance at temperatures outside of the ranges shown
  5. CC = Cooling capacity
  6. PI (kW) = Power Input (Compressor + Fans + Control Power)
  7. COP = Coefficient of performance (CC/PI).
  8. Interpolation between points is permissible. Extrapolation is not permitted.



# Performance Data

**Table 4 - Free cooling mode, 50% water flow**

Unit Size	Ambient air temperature (°C)												
	0						-5						
	LCWT (°C) (30%EG)	CC (kW)	PI (kW)	COP (kW/KW)	ECWT (°C)	Water flow rate Evp (l/s)	Water Pressure Drop (kPa)	CC (kW)	PI (kW)	COP (kW/KW)	ECWT (°C)	Water flow rate Evp (l/s)	Water Pressure Drop (kPa)
RTAD 085 FC STD	7	108.1	15.5	7.0	12.6	5.9	49.3	190.0	15.5	12.2	16.9	5.9	49.1
	9	136.1	15.5	8.8	14.7	6.3	73.9	218.5	15.4	14.2	18.1	6.3	73.7
	11	170.0	15.4	11.1	17.7	6.6	81.4	254.3	15.3	16.6	21.0	6.6	81.2
RTAD 100 FC STD	7	139.0	14.6	9.5	12.3	6.9	33.0	243.8	14.7	16.6	16.3	6.9	32.9
	9	180.0	14.5	12.4	15.5	7.3	36.3	286.2	14.6	19.6	19.3	7.3	36.2
	11	221.2	14.5	15.3	18.5	7.7	39.9	328.7	14.5	22.7	22.1	7.7	39.8
RTAD 115 FC STD	7	152.4	14.8	10.3	11.9	8.1	43.7	267.9	14.7	18.2	15.6	8.1	43.6
	9	195.9	14.7	13.4	15.0	8.5	47.8	312.3	14.6	21.3	18.5	8.5	47.7
	11	239.3	14.6	16.4	17.9	9.0	52.1	356.5	14.5	24.5	21.3	9.0	52.0
RTAD 125 FC STD	7	159.2	20.7	7.7	11.4	9.5	45.8	279.7	20.6	13.6	14.7	9.5	45.7
	9	204.9	20.5	10.0	14.3	10.0	49.8	326.5	20.4	16.0	17.5	10.0	49.6
	11	251.3	20.4	12.3	17.2	10.5	53.9	376.6	20.3	18.6	20.3	10.5	53.8
RTAD 145 FC STD	7	195.5	22.2	8.8	11.7	10.9	45.8	343.5	22.2	15.5	15.3	10.9	45.7
	9	253.4	22.1	11.5	14.8	11.5	50.5	403.7	22.1	18.3	18.2	11.5	50.4
	11	311.7	21.9	14.2	17.7	12.1	55.5	464.1	21.9	21.2	21.0	12.1	55.4
RTAD 150 FC STD	7	195.5	25.6	7.6	11.4	11.5	51.1	343.8	25.5	13.5	14.8	11.5	51.0
	9	253.4	25.4	10.0	14.4	12.1	56.2	404.0	25.3	16.0	17.7	12.1	56.2
	11	311.8	25.2	12.4	17.4	12.8	61.2	464.6	25.2	18.5	20.5	12.8	61.1
RTAD 165 FC STD	7	239.4	27.1	8.8	11.9	12.7	30.0	421.0	27.0	15.6	15.7	12.7	29.9
	9	309.5	26.9	11.5	15.0	13.4	33.0	493.4	26.9	18.4	18.6	13.4	33.0
	11	379.8	26.7	14.2	18.0	14.2	36.2	571.9	26.7	21.5	21.5	14.2	36.1
RTAD 180 FC STD	7	238.5	30.5	7.8	11.6	13.6	33.9	419.7	30.4	13.8	15.1	13.6	33.8
	9	308.4	30.3	10.2	14.6	14.3	37.1	492.0	30.2	16.3	18.0	14.3	37.1
	11	382.4	30.0	12.7	17.6	15.1	40.6	575.1	29.9	19.2	20.9	15.1	40.5
RTAD 085 FC HE	7	133.9	14.7	9.1	12.6	6.3	28.1	235.5	14.7	16.0	16.8	6.3	28.0
	9	173.4	14.6	11.8	15.8	6.7	31.1	276.3	14.7	18.8	19.8	6.7	31.0
	11	213.1	14.6	14.6	18.8	7.1	34.2	317.2	14.6	21.8	22.6	7.1	34.2
RTAD 100 FC HE	7	163.3	20.6	7.9	12.8	7.5	38.7	287.7	20.6	14.0	17.2	7.5	38.6
	9	210.3	20.5	10.3	16.0	8.0	42.7	335.9	20.4	16.5	20.2	8.0	42.6
	11	257.2	20.4	12.6	19.1	8.5	47.0	383.8	20.3	18.9	23.0	8.5	46.9
RTAD 115 FC HE	7	241.3	19.6	12.3	14.1	8.8	37.6	427.9	19.4	22.0	19.6	8.8	37.5
	9	308.6	19.4	15.9	17.6	9.4	41.6	495.9	19.3	25.7	22.8	9.4	41.4
	11	376.3	19.3	19.5	20.9	9.9	45.9	572.2	19.1	29.9	26.0	9.9	45.7
RTAD 125 FC HE	7	197.8	25.6	7.7	12.0	10.3	41.4	348.2	25.5	13.7	15.8	10.3	41.4
	9	256.5	25.4	10.1	15.1	10.9	45.9	409.4	25.3	16.2	18.8	10.9	45.9
	11	315.5	25.2	12.5	18.1	11.6	50.8	470.7	25.1	18.7	21.6	11.6	50.7
RTAD 145 FC HE	7	241.6	27.1	8.9	12.3	11.9	26.5	425.4	27.0	15.7	16.4	11.9	26.4
	9	312.4	26.9	11.6	15.5	12.6	29.3	498.6	26.8	18.6	19.3	12.6	29.2
	11	383.3	26.7	14.3	18.5	13.4	32.4	572.0	26.7	21.5	22.1	13.4	32.3
RTAD 150 FC HE	7	242.9	30.5	8.0	12.3	11.9	26.6	428.2	30.3	14.1	16.4	11.9	26.5
	9	314.2	30.2	10.4	15.5	12.6	29.2	502.2	30.1	16.7	19.4	12.6	29.2
	11	385.6	30.0	12.8	18.5	13.4	32.3	576.3	29.9	19.3	22.2	13.4	32.2

- Notes :
1. Temperature drop = 6°C
  2. 30% ethylene glycol
  3. Ratings based on sea level altitude and evaporator fouling factor of 0.0176 m<sup>2</sup> K/kW
  4. Consult Trane representative for performance at temperatures outside of the ranges shown
  5. CC = Cooling capacity
  6. PI (kW) = Power Input (Compressor + Fans + Control Power)
  7. COP = Coefficient of performance (CC/PI).
  8. ECWT = Entering Chilled Water Temperature
  9. Interpolation between points is permissible. Extrapolation is not permitted.



# Performance Data

**Table 4 - Free cooling mode, 50% water flow**

Unit Size	Ambient air temperature (°C)												
	-10						-15						
	LCWT (°C) (30%EG)	CC (kW)	PI (kW)	COP (kW/KW)	ECWT (°C)	Water flow rate Evp (l/s)	Water Pressure Drop (kPa)	CC (kW)	PI (kW)	COP (kW/KW)	ECWT (°C)	Water flow rate Evp (l/s)	Water Pressure Drop (kPa)
RTAD 085 FC STD	7	275.9	15.5	17.8	21.4	5.9	49.0	366.3	15.5	23.7	26.0	5.9	48.8
	9	306.0	15.4	19.9	21.7	6.3	73.5	398.6	15.4	25.9	25.6	6.3	73.3
	11	343.3	15.3	22.4	24.5	6.6	81.0	436.9	15.3	28.6	28.2	6.6	80.8
RTAD 100 FC STD	7	353.5	14.7	24.1	20.4	6.9	32.8	467.9	14.7	31.8	24.7	6.9	32.7
	9	397.3	14.6	27.2	23.2	7.3	36.1	512.6	14.7	35.0	27.3	7.3	36.0
	11	442.6	14.5	30.5	26.0	7.7	39.7	566.2	14.6	38.9	30.1	7.7	39.6
RTAD 115 FC STD	7	389.2	14.7	26.4	19.5	8.1	43.4	516.6	14.7	35.1	23.6	8.1	43.3
	9	434.4	14.6	29.7	22.2	8.5	47.5	562.3	14.6	38.5	26.1	8.5	47.4
	11	479.1	14.5	33.0	24.8	9.0	51.8	611.1	14.5	42.1	28.6	9.0	51.7
RTAD 125 FC STD	7	406.2	20.5	19.8	18.2	9.5	45.5	538.9	20.5	26.3	21.8	9.5	45.4
	9	453.9	20.4	22.3	20.8	10.0	49.5	591.9	20.3	29.1	24.4	10.0	49.3
	11	509.4	20.2	25.2	23.6	10.5	53.6	649.8	20.1	32.2	27.1	10.5	53.4
RTAD 145 FC STD	7	498.9	22.2	22.5	19.0	10.9	45.7	662.1	22.2	29.9	22.9	10.9	45.6
	9	561.4	22.0	25.5	21.7	11.5	50.4	726.6	22.0	33.0	25.5	11.5	50.3
	11	623.6	21.9	28.5	24.4	12.1	55.4	790.6	21.9	36.1	28.0	12.1	55.3
RTAD 150 FC STD	7	499.7	25.4	19.7	18.3	11.5	51.0	663.5	25.4	26.2	22.0	11.5	50.9
	9	562.2	25.2	22.3	21.1	12.1	56.1	728.3	25.2	28.9	24.6	12.1	56.1
	11	625.0	25.1	24.9	23.8	12.8	61.1	798.8	25.0	32.0	27.3	12.8	61.0
RTAD 165 FC STD	7	612.1	27.0	22.7	19.6	12.7	29.9	813.1	27.0	30.2	23.7	12.7	29.8
	9	686.6	26.8	25.6	22.3	13.4	32.9	897.6	26.8	33.5	26.4	13.4	32.8
	11	777.0	26.6	29.2	25.2	14.2	36.0	995.3	26.5	37.5	29.2	14.2	35.9
RTAD 180 FC STD	7	610.4	30.3	20.2	18.7	13.6	33.7	811.3	30.2	26.9	22.6	13.6	33.6
	9	689.6	30.0	23.0	21.5	14.3	37.0	904.2	29.9	30.2	25.4	14.3	36.9
	11	780.5	29.8	26.2	24.5	15.1	40.4	998.9	29.7	33.7	28.2	15.1	40.3
RTAD 085 FC HE	7	342.2	14.8	23.2	21.2	6.3	27.9	454.4	14.8	30.7	25.8	6.3	27.8
	9	384.3	14.7	26.2	24.0	6.7	30.9	497.5	14.7	33.8	28.3	6.7	30.8
	11	426.2	14.6	29.2	26.6	7.1	34.1	541.2	14.6	37.0	30.8	7.1	34.0
RTAD 100 FC HE	7	419.2	20.5	20.5	21.8	7.5	38.5	558.0	20.4	27.4	26.7	7.5	38.3
	9	468.3	20.3	23.0	24.5	8.0	42.5	607.7	20.3	30.0	29.1	8.0	42.3
	11	516.9	20.2	25.6	27.2	8.5	46.7	656.8	20.1	32.6	31.5	8.5	46.6
RTAD 115 FC HE	7	627.4	19.3	32.5	25.5	8.8	37.3	840.9	19.2	43.9	31.8	8.8	37.1
	9	701.7	19.1	36.7	28.5	9.4	41.2	931.6	19.0	49.1	34.8	9.4	41.0
	11	784.3	19.0	41.4	31.5	9.9	45.5	1012.9	18.8	53.8	37.4	9.9	45.3
RTAD 125 FC HE	7	506.9	25.4	20.0	19.8	10.3	41.3	674.4	25.3	26.6	24.1	10.3	41.3
	9	570.5	25.2	22.6	22.6	10.9	45.8	740.1	25.2	29.4	26.6	10.9	45.8
	11	633.8	25.1	25.3	25.3	11.6	50.7	805.4	25.0	32.3	29.1	11.6	50.6
RTAD 145 FC HE	7	619.2	27.0	22.9	20.6	11.9	26.3	823.6	26.9	30.6	25.1	11.9	26.2
	9	694.5	26.8	25.9	23.3	12.6	29.2	900.5	26.8	33.6	27.6	12.6	29.1
	11	779.5	26.6	29.3	26.2	13.4	32.2	1001.5	26.5	37.7	30.5	13.4	32.1
RTAD 150 FC HE	7	624.1	30.2	20.6	20.7	11.9	26.4	831.2	30.1	27.6	25.2	11.9	26.4
	9	700.5	30.0	23.3	23.5	12.6	29.1	909.6	29.9	30.4	27.8	12.6	29.0
	11	786.7	29.8	26.4	26.3	13.4	32.1	1012.6	29.6	34.2	30.7	13.4	32.0

- Notes :
1. Temperature drop = 6°C
  2. 30% ethylene glycol
  3. Ratings based on sea level altitude and evaporator fouling factor of 0.0176 m<sup>2</sup> K/kW
  4. Consult Trane representative for performance at temperatures outside of the ranges shown
  5. CC = Cooling capacity
  6. PI (kW) = Power Input (Compressor + Fans + Control Power)
  7. COP = Coefficient of performance (CC/PI)
  8. ECWT = Entering Chilled Water Temperature
  9. Interpolation between points is permissible. Extrapolation is not permitted.



# Performance Data

**Table 5 - Free cooling mode, 100% water flow**

Unit Size	Ambient air temperature (°C)												
	0						-5						
	LCWT (°C) (30%EG)	CC (kW)	PI (kW)	COP (kW/KW)	ECWT (°C)	Water flow rate Evap (l/s)	Water Pressure Drop (kPa)	CC (kW)	PI (kW)	COP (kW/KW)	ECWT (°C)	Water flow rate Evap (l/s)	Water Pressure Drop (kPa)
RTAD 085 FC STD	7	101.7	15.6	6.5	9.3	11.8	247.2	177.9	15.6	11.4	10.9	11.8	246.9
	9	131.1	15.5	8.5	11.7	12.5	274.2	208.1	15.5	13.5	13.3	12.5	273.9
	11	160.4	15.4	10.4	14.2	13.2	303.4	237.8	15.4	15.5	15.7	13.2	303.1
RTAD 100 FC STD	7	134.8	14.6	9.2	9.6	13.7	120.9	235.9	14.7	16.1	11.5	13.7	120.8
	9	175.1	14.5	12.0	12.1	14.6	133.8	277.7	14.6	19.0	14.0	14.6	133.6
	11	215.2	14.5	14.9	14.6	15.4	147.5	318.9	14.5	22.0	16.4	15.4	147.3
RTAD 115 FC STD	7	140.9	14.8	9.5	9.3	16.2	160.2	247.0	14.8	16.7	11.0	16.2	160.0
	9	181.9	14.7	12.4	11.8	17.1	176.0	289.2	14.7	19.7	13.4	17.1	175.8
	11	222.6	14.6	15.2	14.2	18.0	192.7	330.9	14.6	22.7	15.8	18.0	192.5
RTAD 125 FC STD	7	149.8	20.7	7.2	9.1	19.0	166.5	262.5	20.6	12.7	10.6	19.0	166.3
	9	193.0	20.5	9.4	11.5	20.0	181.7	306.8	20.5	15.0	13.0	20.0	181.5
	11	235.9	20.4	11.6	13.9	21.0	197.6	350.7	20.4	17.2	15.4	21.0	197.4
RTAD 145 FC STD	7	189.7	22.2	8.5	9.3	21.7	171.3	332.7	22.2	15.0	11.0	21.7	171.2
	9	246.6	22.1	11.2	11.8	23.0	189.7	392.2	22.1	17.8	13.5	23.0	189.6
	11	303.3	22.0	13.8	14.3	24.2	209.5	450.8	21.9	20.5	15.9	24.2	209.4
RTAD 150 FC STD	7	190.5	25.6	7.4	9.2	23.0	191.5	334.6	25.5	13.1	10.8	23.0	191.4
	9	247.3	25.4	9.7	11.7	24.3	211.8	393.8	25.4	15.5	13.2	24.3	211.7
	11	303.9	25.3	12.0	14.1	25.5	231.3	452.3	25.2	18.0	15.6	25.5	231.3
RTAD 165 FC STD	7	230.1	27.1	8.5	9.4	25.4	110.1	403.5	27.1	14.9	11.2	25.4	110.0
	9	297.3	26.9	11.0	11.9	26.9	121.8	472.7	26.9	17.6	13.6	26.9	121.7
	11	364.0	26.8	13.6	14.3	28.4	134.1	540.8	26.7	20.2	16.0	28.4	133.9
RTAD 180 FC STD	7	230.1	30.5	7.5	9.2	27.1	124.6	403.9	30.4	13.3	10.9	27.1	124.5
	9	297.1	30.3	9.8	11.7	28.6	137.2	472.7	30.2	15.6	13.3	28.6	137.1
	11	363.5	30.1	12.1	14.1	30.2	150.7	540.6	30.0	18.0	15.7	30.2	150.6
RTAD 085 FC HE	7	128.3	14.7	8.7	9.7	12.6	102.7	225.0	14.8	15.2	11.7	12.6	102.5
	9	167.0	14.7	11.4	12.3	13.4	114.1	265.5	14.7	18.1	14.2	13.4	113.9
	11	205.7	14.6	14.1	14.8	14.2	126.3	305.4	14.6	20.9	16.6	14.2	126.2
RTAD 100 FC HE	7	149.0	20.7	7.2	9.6	15.1	141.0	261.9	20.6	12.7	11.6	15.1	140.8
	9	193.9	20.5	9.4	12.2	16.0	156.4	308.9	20.5	15.1	14.1	16.0	156.2
	11	238.5	20.4	11.7	14.8	17.0	172.8	355.0	20.4	17.4	16.6	17.0	172.6
RTAD 115 FC HE	7	210.8	19.7	10.7	10.1	17.7	136.6	371.4	19.6	19.0	12.5	17.7	136.4
	9	270.6	19.5	13.9	12.8	18.8	151.8	432.2	19.4	22.2	15.0	18.8	151.6
	11	329.3	19.4	17.0	15.3	19.9	168.2	491.4	19.3	25.5	17.4	19.9	168.0
RTAD 125 FC HE	7	190.5	25.6	7.4	9.4	20.6	154.7	334.9	25.5	13.1	11.3	20.6	154.6
	9	248.2	25.4	9.8	12.0	21.8	172.3	395.6	25.3	15.6	13.7	21.8	172.3
	11	305.8	25.3	12.1	14.5	23.1	191.4	455.3	25.2	18.1	16.1	23.1	191.3
RTAD 145 FC HE	7	230.9	27.1	8.5	9.5	23.7	96.9	405.1	27.1	15.0	11.5	23.7	96.8
	9	298.8	26.9	11.1	12.1	25.2	107.8	475.3	26.9	17.7	13.9	25.2	107.7
	11	366.1	26.8	13.7	14.6	26.7	119.6	544.2	26.7	20.4	16.3	26.7	119.5
RTAD 150 FC HE	7	231.8	30.5	7.6	9.5	23.8	97.3	407.4	30.4	13.4	11.5	23.8	97.2
	9	300.1	30.3	9.9	12.1	25.2	107.6	478.1	30.2	15.8	14.0	25.2	107.5
	11	367.9	30.1	12.2	14.6	26.7	119.2	547.5	30.0	18.3	16.3	26.7	119.1

- Notes :
1. Temperature drop = 6°C
  2. 30% ethylene glycol
  3. Ratings based on sea level altitude and evaporator fouling factor of 0.0176 m<sup>2</sup> K/kW
  4. Consult Trane representative for performance at temperatures outside of the ranges shown
  5. CC = Cooling capacity
  6. PI (kW) = Power Input (Compressor + Fans + Control Power)
  7. COP = Coefficient of performance (CC/PI).
  8. ECWT = Entering Chilled Water Temperature
  9. Interpolation between points is permissible. Extrapolation is not permitted.



# Performance Data

**Table 5 - Free cooling mode, 100% water flow**

Unit Size	Ambient air temperature (°C)												
	-10						-15						
	LCWT (°C) (30%EG)	CC (kW)	PI (kW)	COP (kW/KW)	ECWT (°C)	Water flow rate Evp (l/s)	Water Pressure Drop (kPa)	CC (kW)	PI (kW)	COP (kW/KW)	ECWT (°C)	Water flow rate Evp (l/s)	Water Pressure Drop (kPa)
RTAD 085 FC STD	7	257.3	15.6	16.5	12.7	11.8	246.6	339.7	15.6	21.8	14.5	11.8	246.4
	9	288.0	15.5	18.6	15.0	12.5	273.6	371.0	15.5	24.0	16.7	12.5	273.3
	11	318.2	15.4	20.7	17.3	13.2	302.8	401.6	15.4	26.1	18.9	13.2	302.5
RTAD 100 FC STD	7	341.1	14.7	23.2	13.5	13.7	120.6	450.5	14.8	30.5	15.6	13.7	120.5
	9	384.2	14.6	26.3	15.9	14.6	133.4	494.9	14.7	33.7	17.9	14.6	133.3
	11	426.4	14.6	29.3	18.2	15.4	147.1	537.9	14.6	36.8	20.1	15.4	147.0
RTAD 115 FC STD	7	357.9	14.8	24.2	12.8	16.2	159.8	473.7	14.8	32.0	14.6	16.2	159.6
	9	401.1	14.7	27.3	15.1	17.1	175.7	517.9	14.7	35.2	16.9	17.1	175.5
	11	443.6	14.6	30.4	17.4	18.0	192.3	561.1	14.6	38.4	19.1	18.0	192.1
RTAD 125 FC STD	7	380.3	20.6	18.5	12.2	19.0	166.0	503.3	20.5	24.5	13.9	19.0	165.8
	9	425.6	20.5	20.8	14.6	20.0	181.3	549.5	20.4	26.9	16.2	20.0	181.0
	11	470.3	20.3	23.1	16.8	21.0	197.2	594.8	20.3	29.3	18.4	21.0	197.0
RTAD 145 FC STD	7	482.5	22.2	21.7	12.8	21.7	171.2	638.9	22.2	28.8	14.7	21.7	171.1
	9	544.2	22.1	24.6	15.2	23.0	189.6	702.8	22.1	31.8	17.0	23.0	189.5
	11	604.5	21.9	27.6	17.5	24.2	209.4	764.7	21.9	34.9	19.2	24.2	209.3
RTAD 150 FC STD	7	485.6	25.5	19.1	12.5	23.0	191.4	643.8	25.4	25.3	14.3	23.0	191.3
	9	547.0	25.3	21.6	14.9	24.3	211.6	707.3	25.2	28.0	16.6	24.3	211.5
	11	607.3	25.1	24.2	17.2	25.5	231.2	769.4	25.1	30.7	18.9	25.5	231.1
RTAD 165 FC STD	7	584.7	27.1	21.6	13.0	25.4	109.8	774.0	27.1	28.6	15.0	25.4	109.7
	9	655.7	26.9	24.4	15.4	26.9	121.5	846.5	26.9	31.5	17.2	26.9	121.4
	11	725.1	26.7	27.1	17.7	28.4	133.8	916.9	26.7	34.3	19.4	28.4	133.7
RTAD 180 FC STD	7	585.7	30.3	19.3	12.6	27.1	124.3	775.8	30.3	25.6	14.5	27.1	124.2
	9	656.3	30.1	21.8	15.0	28.6	136.9	847.9	30.1	28.2	16.7	28.6	136.8
	11	725.6	29.9	24.2	17.3	30.2	150.4	918.3	29.9	30.7	18.9	30.2	150.3
RTAD 085 FC HE	7	326.0	14.8	22.0	13.8	12.6	102.4	431.6	14.8	29.1	15.9	12.6	102.2
	9	368.1	14.7	25.0	16.2	13.4	113.8	475.1	14.8	32.2	18.3	13.4	113.6
	11	409.2	14.6	28.0	18.5	14.2	126.0	517.1	14.7	35.2	20.5	14.2	125.9
RTAD 100 FC HE	7	380.5	20.6	18.5	13.7	15.1	140.6	505.0	20.5	24.6	15.9	15.1	140.4
	9	429.4	20.4	21.0	16.1	16.0	156.0	555.4	20.4	27.2	18.2	16.0	155.8
	11	476.8	20.3	23.5	18.5	17.0	172.4	604.0	20.3	29.8	20.5	17.0	172.2
RTAD 115 FC HE	7	540.8	19.5	27.7	15.0	17.7	136.1	719.1	19.4	37.0	17.6	17.7	135.8
	9	602.0	19.4	31.1	17.4	18.8	151.3	780.6	19.3	40.4	19.9	18.8	151.0
	11	661.4	19.2	34.4	19.7	19.9	167.7	840.0	19.2	43.8	22.0	19.9	167.4
RTAD 125 FC HE	7	486.7	25.5	19.1	13.2	20.6	154.5	646.0	25.4	25.4	15.2	20.6	154.5
	9	550.1	25.3	21.8	15.6	21.8	172.2	712.0	25.2	28.2	17.5	21.8	172.1
	11	611.8	25.1	24.4	17.9	23.1	191.2	775.5	25.1	31.0	19.7	23.1	191.1
RTAD 145 FC HE	7	587.5	27.1	21.7	13.5	23.7	96.7	778.3	27.0	28.8	15.6	23.7	96.6
	9	659.6	26.9	24.5	15.8	25.2	107.6	852.0	26.9	31.7	17.8	25.2	107.5
	11	729.8	26.7	27.3	18.1	26.7	119.3	923.2	26.7	34.6	20.0	26.7	119.2
RTAD 150 FC HE	7	591.5	30.3	19.5	13.5	23.8	97.1	784.6	30.3	25.9	15.6	23.8	97.0
	9	664.4	30.1	22.1	15.9	25.2	107.4	859.3	30.1	28.6	17.9	25.2	107.2
	11	735.4	29.9	24.6	18.2	26.7	119.0	931.4	29.9	31.2	20.1	26.7	118.8

- Notes :
1. Temperature drop = 6°C
  2. 30% ethylene glycol
  3. Ratings based on sea level altitude and evaporator fouling factor of 0.0176 m<sup>2</sup> K/kW
  4. Consult Trane representative for performance at temperatures outside of the ranges shown
  5. CC = Cooling capacity
  6. PI (kW) = Power Input (Compressor + Fans + Control Power)
  7. COP = Coefficient of performance (CC/PI)
  8. ECWT = Entering Chilled Water Temperature
  9. Interpolation between points is permissible. Extrapolation is not permitted.

# Performance Data

**Figure 3 - Evaporator Water Pressure Drops - Standard Cooling mode**

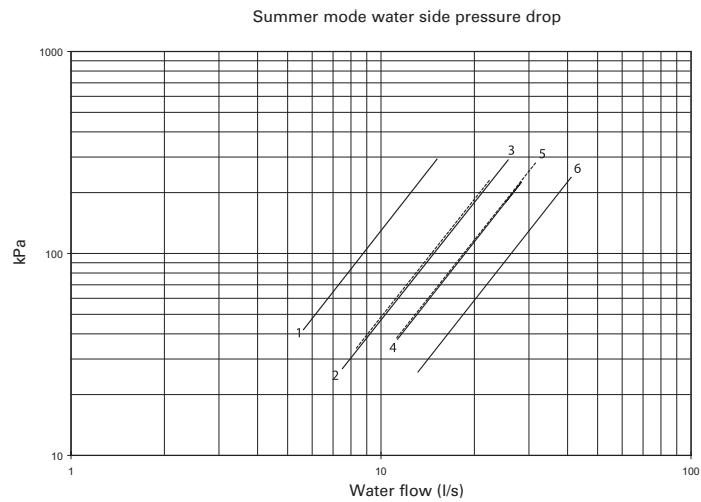

- 1 = 085 FC STD
- 2 = 085 FC HE, 100 FC STD
- 3 = 100 FC HE, 115 FC STD
- 4 = 115 FC HE, 125 FC HE, 145 FC STD, 150 FC STD
- 5 = 125 FC STD
- 6 = 145 FC HE, 150 FC HE, 165 FC STD, 180 FC STD

**Figure 4 - Evaporator Water Pressure Drops - Free Cooling mode**

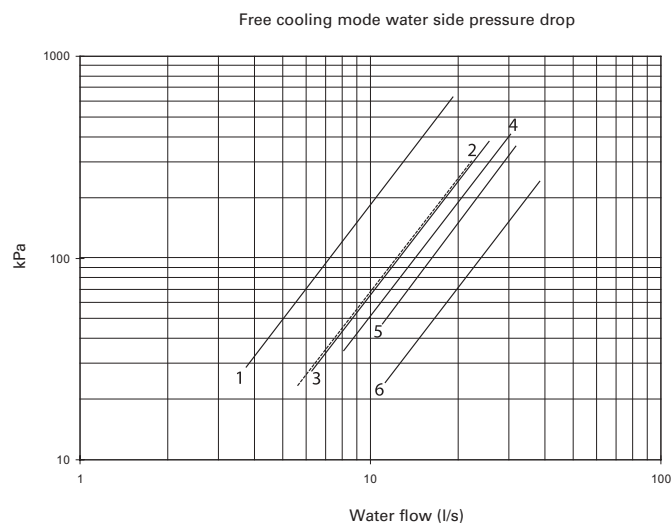

- 1 = 085 FC STD
- 2 = 085 FC HE, 100 FC STD
- 3 = 100 FC HE, 115 FC STD
- 4 = 115 FC HE, 125 FC HE, 145 FC STD, 150 FC STD
- 5 = 125 FC STD
- 6 = 145 FC HE, 150 FC HE, 165 FC STD, 180 FC STD



# Performance Data

**Table 6 - Performance Data Adjustment Factors**

Fouling Factor	°C Chilled Water Temp. drop	Altitude											
		Sea Level			600 m			1200 m			1800 m		
		Cooling Capacity	Evp. Flow Rate	Compr. kW Input	Cooling Capacity	Evp. Flow Rate	Compr. kW Input	Cooling Capacity	Evp. Flow Rate	Compr. kW Input	Cooling Capacity	Evp. Flow Rate	Compr. kW Input
0.0176 m <sup>2</sup> K/kW	4.4	1.000	1.249	1.000	0.996	1.245	1.004	0.991	1.240	1.007	0.987	1.234	1.014
	5.6	1.000	1.000	1.000	0.997	0.996	1.004	0.993	0.992	1.007	0.988	0.988	1.015
	6.7	1.001	0.835	1.001	0.997	0.832	1.004	0.993	0.828	1.009	0.988	0.824	1.015
	7.8	1.003	0.716	1.001	0.999	0.714	1.004	0.994	0.711	1.009	0.990	0.708	1.015
	8.9	1.004	0.628	1.001	1.000	0.626	1.005	0.997	0.623	1.009	0.991	0.620	1.016
0.044 m <sup>2</sup> K/kW	4.4	0.988	1.235	0.996	0.984	1.230	1.000	0.980	1.225	1.004	0.975	1.220	1.010
	5.6	0.988	0.989	0.998	0.986	0.985	1.000	0.981	0.981	1.004	0.977	0.976	1.011
	6.7	0.990	0.825	0.998	0.987	0.822	1.000	0.983	0.819	1.005	0.978	0.815	1.011
	7.8	0.991	0.708	0.998	0.988	0.706	1.001	0.984	0.703	1.005	0.980	0.700	1.011
	8.9	0.993	0.621	0.999	0.990	0.619	1.001	0.986	0.617	1.006	0.981	0.614	1.012

**Table 7 - Ethylene glycol percentage and flow rate adjustment factor**

	Ethylene glycol percentage				
	25%	30%	35%	40%	45%
Flow rate adjustment factor	0.979	1	1.024	1.05	1.078





# Electrical Data

**Table 8 - Compressor motor electrical data - 50 Hz**

Unit Size	Nominal voltage (V/Ph/Hz)	Maximum unit kW (kW)	Maximum RLA (1) (A)	Starting amps (2) (A)	Power factor
RTAD 085 FC STD	400/3/50	149	239	251	0.90
RTAD 100 FC STD	400/3/50	169	278	302	0.88
RTAD 115 FC STD	400/3/50	199	319	355	0.89
RTAD 125 FC STD	400/3/50	244	391	429	0.90
RTAD 145 FC STD	400/3/50	268	431	465	0.90
RTAD 150 FC STD	400/3/50	291	471	496	0.89
RTAD 165 FC STD	400/3/50	294	520	563	0.89
RTAD 180 FC STD	400/3/50	352	569	601	0.89
RTAD 085 FC HE	400/3/50	149	239	251	0.90
RTAD 100 FC HE	400/3/50	174	286	310	0.88
RTAD 115 FC HE	400/3/50	204	327	363	0.89
RTAD 125 FC HE	400/3/50	249	399	437	0.90
RTAD 145 FC HE	400/3/50	273	439	473	0.90
RTAD 150 FC HE	400/3/50	296	479	504	0.89

(1) To take in account for the sizing of power cables  
 (2) 3 compressor at full load, the fourth one starting

**Table 9 - General electrical data**

Unit Size	Nominal voltage (V/Ph/Hz)	Crankcase heater Compressor (W)	Control circuit (VA)	Short circuit intensity (kA)
RTAD 085 FC STD	400/3/50	150	1600	35
RTAD 100 FC STD	400/3/50	150	1600	35
RTAD 115 FC STD	400/3/50	150	1600	35
RTAD 125 FC STD	400/3/50	150	1600	35
RTAD 145 FC STD	400/3/50	150	1600	35
RTAD 150 FC STD	400/3/50	150	1600	35
RTAD 165 FC STD	400/3/50	150	1600	35
RTAD 180 FC STD	400/3/50	150	1600	35
RTAD 085 FC HE	400/3/50	150	1600	35
RTAD 100 FC HE	400/3/50	150	1600	35
RTAD 115 FC HE	400/3/50	150	1600	35
RTAD 125 FC HE	400/3/50	150	1600	35
RTAD 145 FC HE	400/3/50	150	1600	35
RTAD 150 FC HE	400/3/50	150	1600	35



# Electrical Data

**Table 10 - Electrical connections**

Unit Size	Compressor fuse size (1) (A)	Disconnect switch size (1) (A)	Minimum connecting wire (1) (mm <sup>2</sup> )	Maximum connecting wire (1) (mm <sup>2</sup> )
RTAD 085 FC STD	6 x 125	250	95	150
RTAD 100 FC STD	6 x 160	400	185	240
RTAD 115 FC STD	6 x 200	400	185	240
RTAD 125 FC STD	6 x 250	500	240	240
RTAD 145 FC STD	6 x 250	500	240	240
RTAD 150 FC STD	6 x 250	630	2 x 150	2 x 300
RTAD 165 FC STD	315 + 250	630	2 x 150	2 x 300
RTAD 180 FC STD	6 x 315	630	2 x 150	2 x 300
RTAD 085 FC HE	6 x 125	250	95	150
RTAD 100 FC HE	6 x 160	400	185	240
RTAD 115 FC HE	6 x 200	400	185	240
RTAD 125 FC HE	6 x 250	500	240	240
RTAD 145 FC HE	6 x 250	500	240	240
RTAD 150 FC HE	6 x 250	630	2 x 150	2 x 300

(1) To take in account for the sizing of power cables

# Mechanical Specifications

---

## General

Units are leak and pressure tested at 35 bar high side, 19 bar low side, then evacuated and charged. Packaged units ship with a full operating charge of oil and refrigerant. Unit panels, structural elements and control boxes are constructed of galvanized steel and mounted on a welded structural steel base. Unit panels and control boxes are finished with an air-dry paint RAL 9002.

## Evaporator

The evaporator is a tube-in-shell heat exchanger design with internally finned copper tubes roller expanded into the tube sheet. The evaporator is designed, tested and stamped in accordance with the appropriate pressure vessel code approval for a refrigerant side working pressure of 32 bar. The evaporator is designed for a water side working pressure of 14 bar. Water connections are Victaulic connections. The evaporator has one water pass with a series of internal baffles. Each shell includes a vent, a drain and fittings for temperature control sensors and is insulated with 3/4 inch Armaflex II or equal insulation (K=0.26). Heat tape is provided to protect the evaporator from freezing at ambient temperatures down to -18°C.

## Condenser and Fans

Air-cooled condenser coils have aluminum fins mechanically bonded to internally finned seamless copper tubing. The condenser coil has an integral subcooling circuit. Condensers are factory leak tested at 35 bar. Direct-drive vertical discharge air foil ZephyrWing condenser fans are dynamically balanced. Three-phase condenser fans motors with permanently lubricated ball bearing are provided. Standard units will start and operate between of 4°C (39 F) to the maximum possible ambient of the selected unit.

## Free Cooling Coil

The Free Cooling coil has aluminum fins mechanically bonded to internally finned seamless 5/8" copper tubing. Free Cooling coil is factory leak tested.

## Piping and 3 Way Control Valve

The 3-way control valve has a cast iron GG25 body with flanged end connections, stainless steel trim, controlled by a 1800Nm/24V actuator. The Free Cooling piping is a 4" or 5" steel line with Victaulic connections on both evaporator side and Free Cooling coil side.



# Mechanical Specifications

---

## Compressor and Lube Oil System

The rotary screw compressor is semi-hermetic, direct drive, 3000 rpm, with capacity control slide valve, a load/unload valve, rolling element bearings, differential refrigerant pressure oil pump, oil filter and oil heater. The motor is a suction gas cooled, hermetically sealed, two-pole squirrel cage induction motor. Oil separator devices are provided separate from the compressor. Check valves in the compressor discharge and lube oil system are provided.

## Refrigeration Circuits

Each unit has two refrigerant circuits, with one rotary screw compressor per circuit. Each refrigerant circuit includes a liquid line shutoff valve, removable core filter drier, charging port and an electronic expansion valve. Fully modulating compressors and electronic expansion valves provide variable capacity modulation over the entire operating range.

## Unit Controls

All unit controls are housed in a weather-tight enclosure with hinged doors to allow for customer connection of power wiring and remote interlocks. All controls, including sensors, are factory mounted and tested prior to shipment. All cataloged units comply with EN 60204 and are EMC compatible.

The Free Cooling mode temperature change over can be set using the control display. The automatic changeover between Compressor mode and Free Cooling mode is done by using a sensor that measures the outside air temperature (OAT °C). It will anticipate the Free Cooling coil capacity and will determine if it can overcome the building load and maintain the chilled water setpoint. If the Free Cooling exchanger capacity decreases (increase of OAT °C) the unit will switch into Compressor mode allowing the unit to maintain the chilled water setpoint.



## Mechanical Specifications

---

Microcomputer controls provide all control functions including start-up and shut down, leaving chilled water temperature control, compressor and electronic expansion valve modulation, fan sequencing, antirecycle logic, automatic lead/lag compressor starting and load limiting. The unit control module, utilizing Adaptive Control™ microprocessor, automatically takes action to avoid unit shutdown due to abnormal operating conditions associated with low refrigerant temperature, high condensing temperature and motor current overload. Should the abnormal operating condition continue until a protective limit is violated, the unit will be shut down. Unit protective functions include loss of chilled water flow, evaporator freezing, loss of refrigerant, low refrigerant pressure, high refrigerant pressure, reverse rotation, compressor starting and running over current, phase loss, phase imbalance, phase reversal, and loss of oil flow.

A menu driven digital display indicates over 20 operating data points including chilled water setpoint, current limit setpoint, leaving chilled water temperature, evaporator and condenser refrigerant pressures and temperatures. Over 60 diagnostic checks are made and displayed when a problem is detected. The digital display can be read and advanced on the unit without opening any control panel doors. Standard power connections include main three phase power and two 115 volt single phase power connections for control power and heat tape.

### Starters

Starters are housed in a weathertight enclosure with removable cover plate to allow for customer connection of power wiring. Wye Delta closed transition starters are standard on all RTAD units.



## Notes

---



## Notes

---



Quality Management  
System Approval



---

Literature Order Number	RLC-PRC024-E4
-------------------------	---------------

---

Date	0505
------	------

---

New	
-----	--

---

Literature Stocking Location	Europe
------------------------------	--------

---

*Trane has a policy of continuous product and product data improvement and reserves the right to change design and specifications without notice.*

**www.trane.com**

For more information, contact your local district office or e-mail us at [comfort@trane.com](mailto:comfort@trane.com)

American Standard Europe BVBA  
Registered Office: 1789 Chaussée de Wavre, 1160 Brussels - Belgium